



Part of Energy Queensland

Earthing Standard

Standard for Distribution Earthing

These standards created and made available are for the construction of Energy Queensland infrastructure. These standards ensure meeting of Energy Queensland's requirements. External companies should not use these standards to construct non-Energy Queensland assets.

If this standard is a printed version, to ensure compliance, reference must be made to the Energy Queensland internet site www.energyq.com.au to obtain the latest version.

Approver	Jason Hall – GM Grid Technology
If RPEQ Sign-off required insert details below.	
Certified Person Name and Position Title	Registration Number
Rob Coggan: Manager Protection and Earthing	11801
Emma Lennon: Senior Earthing Standards Engineer	20397

Abstract: This document sets out Energex's earthing philosophy and general requirements for the distribution network.

Keywords: Distribution Earthing, Energex Earthing, Earthing Standards

CONTENTS

1	Overview	8
1.1	Purpose	8
1.2	Scope	8
2	References	8
2.1	Legislation, regulations, rules, and codes.....	8
2.2	Energy Queensland controlled documents.....	8
2.3	Other sources	9
3	Definitions and abbreviations	9
3.1	Abbreviations	9
4	Function and Earthing	10
5	Earthing Parameters	10
5.1	General.....	10
5.2	Hazardous Voltages.....	11
5.3	Soil Resistivity.....	11
5.4	Earthing Electrodes.....	12
5.5	Earthing Locations	14
6	Minimum Design Requirements	15
6.1	Design Objective.....	15
7	Distribution Earthing Systems	16
7.1	Low Voltage Multiple Earthed Neutral (MEN) System	16
7.3	The Common Multiple Earthed Neutral (CMEN) System.....	17
7.4	Separately Earthed System Consisting of a Low Voltage Multiple Earthed Neutral (MEN) System and High Voltage Earth	18
7.5	Accessible Metalwork.....	19
7.6	Single Wire Earth Return (SWER) Earthing	19
7.7	Transmission and Sub-Transmission Earthing	20
8	Overhead Distribution Earthing Philosophy and Practice.....	21
8.1	Pole-Mounted Distribution Transformers	21
8.1.1	CMEN System	21
8.1.2	Separately Earthed High Voltage and Low Voltage (MEN) System.....	22
8.1.3	Single Wire Earth Return (SWER) Earthing	22
8.2	Timber Distribution Poles	24
8.2.1	CMEN System	24
8.2.2	Separately Earthed High Voltage and Low Voltage (MEN) System.....	24
8.3	Conductive Distribution Poles (Concrete and Steel).....	24

Standard for Distribution Earthing



8.3.1	General.....	24
8.3.2	MEN	24
8.3.3	CMEN System	24
8.3.4	Separately Earthed High Voltage and Low Voltage (MEN) System.....	25
8.4	33kV Overhead Earthwire (OHEW).....	26
8.4.1	General.....	26
8.4.2	Timber Poles	26
8.4.2.1	General.....	26
8.4.2.2	CMEN	27
8.4.2.3	Separately Earthed	27
8.4.3	Conductive Poles.....	27
8.4.3.1	General.....	27
8.4.3.2	CMEN.....	27
8.4.3.3	Separately Earthed	27
8.5	Steel Crossarms	28
8.5.1	Wooden Poles	28
8.5.2	Conductive Poles.....	28
8.6	HV Pole-Mounted Equipment (Recloser, Regulator, Enclosed Switch)	28
8.6.1	General.....	28
8.6.2	CMEN System	28
8.6.3	Separately Earthed High Voltage and Low Voltage (MEN) System.....	28
8.7	Distribution Equipment on Transmission Poles	29
8.8	Metal Work at Ground Level.....	29
8.8.1	Pole Nails/Stakes and Rebutted Pole Steel Sleeves.....	29
8.8.2	Metallic Cable Guards Protecting Low Voltage Cables	29
8.8.2.1	CMEN System	29
8.8.2.3	Separately Earthed High Voltage and Low Voltage (MEN) System.....	30
8.8.3	Metallic Cable Guard Protecting High Voltage Cable	30
8.8.3.1	General.....	30
8.8.3.2	CMEN System	30
8.8.3.3	Separately Earthed High Voltage and Low Voltage (MEN) System.....	31
8.8.4	Air Break Switch (ABS) Handles and Metallic Down Rods	32
8.8.4.1	General.....	32
8.8.4.2	CMEN system.....	32
8.8.4.3	Separately Earthed High Voltage and Low Voltage (MEN) System.....	33
8.8.5	Stay Wires	34

Standard for Distribution Earthing



8.8.6	All Other Metalwork within 2.4m from the Ground	34
8.9	HV Aerial Bundled Conductor	34
8.9.1	General.....	34
8.9.2	CMEN System	35
8.9.3	Separately Earthed High Voltage and Low Voltage (MEN) System.....	35
8.10	High Voltage Covered Conductor.....	36
8.10.1	CMEN System	36
8.10.2	Separately Earthed High Voltage and Low Voltage (MEN) System.....	36
9	Underground Distribution Earthing Philosophy and Practice	36
9.1	Low Voltage Cable Pole Termination	36
9.2	High Voltage Cable Pole Termination	36
9.2.1	General.....	36
9.2.2	CMEN System	36
9.2.3	Separately Earthed High Voltage and Low Voltage (MEN) System.....	36
9.3	Cable Screen	36
9.4	Padmount Distribution Substations	37
9.4.1	CMEN System	37
9.4.2	Separately Earthed High Voltage and Low Voltage (MEN) System.....	38
9.5	Outdoor Ground Substations.....	39
9.5.1	General.....	39
9.5.2	CMEN System	39
9.5.3	Separately Earthed High Voltage and Low Voltage (MEN) System.....	40
9.6	Free-Standing 11kV Equipment	40
9.6.1	General.....	40
9.6.2	CMEN System	41
9.6.3	Separately Earthed High Voltage and Low Voltage (MEN) System.....	41
9.7	Indoor Distribution Substations	42
10	Streetlight.....	43
10.1	Streetlight Columns.....	43
10.1.1	Rate 1 and Rate 2 Lighting Arrangements	43
10.1.2	Non-Metered (Rate 3) Public Lighting	43
10.1.4	Remote Areas and Bridges.....	44
10.1.5	Joint Use Poles – Isolation.....	44
10.1.6	Lighting Columns on Foreshores or near Water Parks.....	44
11	Telstra and Optus Plants	44
11.1	Telstra / Energex Power Coordination Guidelines	44

Standard for Distribution Earthing



11.2	Remote HV Earth.....	45
11.3	Street Mounted Telecommunication Equipment.....	47
11.4	Telstra Metallic Sheathed Cable Types.....	47
12	Queensland Rail Traction Earth.....	48
12.1	General Guidelines.....	48
12.2	Non-Standard Arrangement.....	49
13	Customer Installation Earthing.....	49
13.1	General.....	49
13.2	Non-Standard Arrangement.....	49
14	Mitigation Measures.....	50
14.1	General.....	50
14.2	Grading Ring.....	50
14.3	Reducing Resistance of Return Path.....	51
14.4	Deep Earth with Upper Level Insulation.....	51
14.5	Insulation Layer.....	51
14.6	Non-Conductive Fence.....	52
14.7	Double Insulation (or Reinforced Insulation).....	52
14.8	Separation of Structures and Earths from 110/132kV Transmission Structures.....	52
	Appendix A.....	54
	Revision History.....	54
	Appendix B.....	56
	Consideration of EPR – Table of Minimum Separations between Telstra Plant and HV Distribution Plant Earthing Systems.....	56
	Appendix C.....	58
	Probabilistic Earthing Design (AS 2067, 2016).....	58
C.1	Probabilistic Earthing Design.....	58
C1.1	Step 1: Data Gathering.....	59
C.1.1.1	Fault Levels and Protection Clearing Times.....	59
C1.2	Step 2: Initial Concept Design.....	59
C.1.2.1	Fault Current.....	60
C.1.2.2	Earth Fault Duration.....	60
C.1.2.3	Soil Resistivity.....	61
C.1.2.4	Layout Practicalities.....	61
C.1.2.5	Co-ordinated Design.....	61
C.1.2.6	Current Injection.....	61
C.1.2.6.1	Special Considerations.....	62
C1.3	Step 3: Determine Design EPR.....	62

C1.4 Step 4: Detailed Earthing Layout.....	62
C.1.4.1 Earthing Conductor Layout.....	62
C.1.4.2 Dimensioning of Earth Conductors	63
C.1.4.3 Transferred Potentials	64
C.1.4.4 Hazard Location Identification	64
C1.5 Step 5: Standard V/t Criteria Chosen (from case studies)	66
C1.6 Step 6: Perform Direct Probabilistic Design.....	69
C1.7 Step 7: Mitigate / Redesign	69
C1.8 Step 8: Lightning / Transient Design	70
C1.9 Step 9: Construction Support	70
C1.10 Step 10: Commissioning Program and Compliance Review.....	72
Appendix D	73
Consideration of LFI – Flowchart Indicating Maximum Parallel Exposure before LFI is likely to exceed Acceptable Limits.....	73
Appendix E	74
Summary of Distribution Equipment and Earthing Requirements	74
Appendix F.....	84
Disclaimer	84

FIGURES

Figure 1: Horizontal Separation Between Electrodes	13
Figure 2: Typical CMEN Earthing System (illustrated for overhead network).....	17
Figure 3: Typical Separate Earthing System for Overhead Network.....	18
Figure 4: Typical Separate Earthing System for Underground Network.....	19
Figure 5: SWER Earthing System	20
Figure 6: Pole Transformer with CMEN Earthing System.....	21
Figure 7: Pole Transformer with Separate Earthing System.....	22
Figure 8: SWER Transformer Earthing.....	24
Figure 9: Conductive Pole with 11kV and LV, CMEN Earthing	25
Figure 10: Conductive Pole with Separate Earthing	26
Figure 11: Metallic Cable Guard with CMEN Earthing	31
Figure 12: Metallic Cable Guard with Separate Earthing	32
Figure 13: Air Break Switch Handle with CMEN Earthing.....	33
Figure 14: Air Break Switch Handle with Separate Earthing.....	34
Figure 15: HV ABC Cable Earthing	35
Figure 16: Label for HV Earth Tie to CMEN	38
Figure 17: Padmount Transformer with Separate Earthing.....	39
Figure 18: General Arrangements for Remote HV Earth and Telstra Plants.....	46
Figure 19: Grading Ring Reduction of Touch Potential	50
Figure 20: Deep Earth Electrode with Insulated Top Section	51

TABLES

Table 1: Typical Resistivity of Different Soil Types	11
Table 2: Calculated Theoretical Electrode Resistance for Various Values of Soil Resistivity	13

1 Overview

1.1 Purpose

This document sets out Energex's earthing philosophy and general requirements for the distribution network.

1.2 Scope

This Standard outlines the standard Energex distribution earthing practices for low voltage and 11kV systems and includes some guidelines for higher voltages on the overhead network (i.e., 33kV OHEW, ABS and reclosers, transmission 110/132kV.) References to 'low voltage' (abbreviated LV) apply to 415V systems and below. References to 'high voltage' (abbreviated HV) apply to the 11kV distribution system and associated equipment only. This Standard does not cover transmission, sub-transmission, zone, and bulk supply substations earthing.

Requirements for the installation, inspection, testing and maintenance of distribution earthing systems are outside of the scope of this document.

2 References

2.1 Legislation, regulations, rules, and codes

Queensland Electricity Act, 1994 (Queensland Government)

Queensland Electricity Regulation, 2006 (Queensland Government)

Queensland Electrical Safety Act, 2002 (Queensland Government)

Queensland Electrical Safety Regulation, 2013 (Queensland Government)

Queensland Work Health and Safety Act, 2011 (Queensland Government)

Queensland Work Health and Safety Regulation, 2011 (Queensland Government)

2.2 Energy Queensland controlled documents

EnergexOverheadDesignManual-3061972

EnergexCommercialandIndustrialSubstationManual-3060052

EnergexOverheadConstructionManual

PlantRatingManual-4179110

StandardforNetworkLabellingandSignage-3060382

QueenslandPublicLightingDesignManual-3047335

EnergexSupplyandPlanningManual

EnergexUndergroundDistributionConstructionManual

EnergexTelstraPowerCoordinationGuidelines

WorkCategorySpecificationWCS34.1SWEREarthingSystems,InspectandTest-690014 Work

CategorySpecificationWCS34.2EarthingSystems,InspectandTest-690706

2.3 Other sources

IEEE Guide for Safety in AC Substation Grounding, (IEEE Std 80, 2013) (IEEE)

Substations and high voltage installations exceeding 1 kV a.c, (AS 2067, 2016) (Standards Australia)

Lightning protection, AS 1768 – 2021

Electrical installations (Wiring Rules), AS/NZS 3000 – 2018

Approval and test specification — General requirements for electrical equipment, AS/NZS 3100 –2022

Electric cables - Cross-linked polyethylene insulated - Aerial bundled - For working voltages up to and including 0.6/1(1.2) kV, Part 1: Aluminium conductors, AS/NZS 3560.1 – 2000

Electric cables - Cross-linked polyethylene insulated - Aerial bundled - For working voltages up to and including 0.6/1(1.2) kV, Part 2: Copper conductors, AS/NZS 3560.2 – 2003

Earth potential rise - Protection of telecommunications network users, personnel, and plant (Series), AS/NZS 3835

Electrical hazards on metallic pipelines, AS/NZS 4853 – 2012

Effects of current on human beings and livestock (Series), AS/NZS IEC 60479

Overhead line design, AS/NZS 7000 – 2016

Coordination of power and telecommunications - Low Frequency Induction (LFI) - Code of practice for the mitigation of hazardous voltages induced into telecommunications lines, HB 101 – 1997

Electrical Safety Code of Practice 2020 – Works, Queensland Electrical Safety Office.

Earthing Risk software available from ENA website, ENA ARGON

Power System Earthing Guide (EG-0) Part 1: Management Principles, ENA DOC 025-2022

Substation Earthing Guide (EG-1), ENA DOC 045 – 2022

3 Definitions and abbreviations

3.1 Abbreviations

This list does not include well-known unambiguous abbreviations, or abbreviations defined at their first occurrence within the text.

ABC	Aerial Bundled Conductor
ABS	Air Break Switch
BPM	Base Plate Mounted
CCT	Covered Conductor Thick
CMEN	Common Multiple Earth Neutral
CU	Compatible Unit
EPR	Earth Potential Rise
FAQ	Frequently Asked Questions
HV	High Voltage

m	Metres
OHCM	Overhead Construction Manual
OHEW	Overhead Earth Wire
OPGW	Optical-fibre Ground Wire
LV	Low Voltage
MEN	Multiple Earthed Neutral
LFI	Low Frequency Induction
RMU	Ring Main Unit
SBM	Slip Base Mounted
SC	Stock Code
SWER	Single Wire Earth Return
VDR	Vertical Delta Rural
VOR	Vertical Offset Rural

4 Function and Earthing

The electrical earthing system is designed to provide safe and correct operation of the network under normal, earth fault and transient conditions.

During earth fault conditions, large fault currents may flow via the general mass of earth enroute to the neutral point of the source transformer. The impedance of any 'earthed' metalwork (transformer tanks, switchgear enclosures, earth grids etc.) with respect to the 'true' or 'reference' earth can lead to a rise in potential that, if unmanaged, may pose a significant hazard to Energex staff and/or the general public.

A low impedance earth is also required to effectively shunt transient overvoltages (caused by lightning discharges, switching surges or other system disturbances) safely to earth. These overvoltages may cause extensive damage to equipment including ancillary items such as communications cables. Equipment damage might include insulation breakdown, thermal or mechanical damage and may result in electrically ignited explosions.

5 Earthing Parameters

5.1 General

The effectiveness of an earthing system is highly dependent on the interface between the general body of earth and the system itself. The resistance of the electrodes, the body of earth and the contact resistance at the interface must be sufficiently low as to remain within acceptable voltage limits in the presence of earth fault or transient currents. The rise in potential of the earthing system under earth fault or transient conditions with respect to a remote reference point (assumed far enough away to be at 'true earth' or zero potential) is commonly referred to as 'Earth Potential Rise' (EPR). Typically, the electrode and its contact resistance are negligible, and the resistance of earthing system will depend primarily on the resistivity of the soil in the area.

5.2 Hazardous Voltages

While earth potential rise (EPR) exists on an earthing system, hazardous voltages in the form of touch, step and transfer potentials may be present on and around the earthing installation. These hazardous voltages are defined as follows:

- Touch potential: the difference between the EPR of an earthing system and the ground surface potential at a distance of 1m. This is the difference between a person's hand touching an energised object and their feet which is typically assumed to be 1 m out from the energised object
- Step potential: the difference in ground surface potential between a person's feet spaced 1m apart
- Transfer potential: the potential difference that may exist between the local earthing system and a metallic object (e.g. fences, pipes) bonded to a distant location that may be at a different potential.

The level of hazard present at a site during a fault or transient condition is site specific and determined by factors including but not limited to soil conditions, protection clearing times, fault current and current path.

5.3 Soil Resistivity

Conduction in soil is primarily ionic. Consequently, the resistivity of soil is determined by the quantity of moisture and dissolved conductive salts within the soil. When completely dry, most soils are non-conductive.

The main factors, which determine the resistivity of soil, are:

- type of soil
- salt dissolved in the contained water
- moisture content
- temperature
- grain size
- closeness of packing and pressure.

Typical values of earth resistivity are shown in Table 1 below.

Table 1: Typical Resistivity of Different Soil Types

Type of Earth	Typical Resistivity ($\Omega.m$)
<i>Wet organic soil</i>	<i>10</i>
<i>Clay silt</i>	<i>50</i>
<i>'Typical' soil</i>	<i>100</i>
<i>Moist sand and gravel</i>	<i>200</i>
<i>Loam and broken stone</i>	<i>300</i>
<i>Slate, shale, sandstone</i>	<i>500</i>
<i>Very dry soil</i>	<i>1 000</i>

<i>Type of Earth</i>	<i>Typical Resistivity ($\Omega.m$)</i>
<i>Dry sand</i>	<i>2000</i>
<i>Stony / rocky ground</i>	<i>2000</i>
<i>Dry gravel</i>	<i>3000</i>
<i>Bed rock</i>	<i>10 000</i>

Furthermore, the structure of the soil at most locations will be non-homogeneous, consisting of multiple layers of soil types of differing resistances. The best way of accurately determining the soil resistivity at a particular site is to measure it directly.

Earthing can be expected to require less effort in the following conditions:

- soil with humus and moisture
- alluvial soils
- clay soils.

In the following areas, earthing can be expected to be difficult:

- rock
- mountain tops—generally salt-depleted and rocky
- coarse sand and gravel
- near sandy beaches (since moisture tends to drain from sand).

It should also be recognised that soil resistivity varies with the seasons. In wetter months the soil resistivity will be low and in drier months it will be higher. Adequate earthing should be installed to ensure the target resistances are achieved in the drier periods.

Generally, the required earthing system resistances defined in this Standard will be easily obtainable in the field. However, in areas with poor soil conditions or high soil resistivity due to soil composition or seasonal variation, further attention to the earthing design may be required.

5.4 Earthing Electrodes

Earthing systems consist of vertical electrodes interconnected with earthing cable. The standard electrode used for distribution earthing within Energex is a copper-clad steel rod of dimensions 1440mm x 13mm diameter (previously 1800mm x 13mm diameter earth rod). The steel core provides the strength necessary to drive the rod into the ground and the copper cladding provides corrosion resistance and allows a direct copper to copper connection between the earthing conductor and the electrode. The rod is driven so that its top is 500mm below surface level, so that there is adequate protective cover for the cable connected to it and to minimise the effect of seasonal variation in the upper layers of soil.

In addition, pole butt earths are approved for use as an earthing electrode in the Energex overhead network. Measurements are made of the earth resistance at the time of construction (before and after connection to the neutral of the network) and additional electrodes are added until the required target earthing resistance is achieved. If soil resistivity increases with depth (e.g., soil over rock) then additional electrodes are installed over a wider area. Where resistivity decreases with depth, earth rods may be coupled to achieve a deeper penetration to reach the lower resistivity soils. Sandy soils are often leached of conductive matter and many electrodes may be joined to strike lower layers with moisture and conductive salts.

There should be adequate horizontal spacing between electrodes to ensure effectiveness; otherwise, the rods are connecting into the same patch of soil with little additional benefit. In fact, a separation distance of twice the electrode depth is recommended, as shown in Figure 1 below. In practice, there should be a minimum of several metres spacing between electrodes.

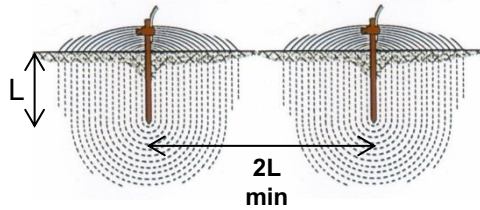

Figure 1: Horizontal Separation Between Electrodes

Table 2 below gives calculated earthing resistance values for earthing electrodes in different soil resistivities for:

- A single earth rod
- Two earth rods, horizontally separated
- Two electrodes connected vertically.

Table 2: Calculated Theoretical Electrode Resistance for Various Values of Soil Resistivity

Soil Resistivity (Ω.m)	Earth Resistance (Ω)					
	Single Rod (13 mm Dia)		Two Rods Horizontal Separation		Two Rods Joined Vertically	
	1.8m	1.44m	1.8m	1.44m	1.8m	1.44m
10	5.3	6.4	2.9	3.5	3	3.6
20	10.6	13	5.8	7	5.9	7.2
30	15.9	19	8.6	10.5	8.9	10.7
40	21.3	26	11.5	14	11.9	14.3
50	26.6	32	14.4	17.5	14.8	17.9
60	31.9	38	17.3	21	17.8	21.5
70	37.2	45	20.1	24.5	20.7	25.1
80	42.5	51	23	28	23.7	28.6
90	47.8	58	25.9	31.5	26.7	32.2
100	53	63	28.8	35	29.6	35.8
200	106	128	58	70	59	71.6
500	266	320	144	175	148	179
1000	531	639	288	350	296	358

To minimise vibration and ensure good electrode-to-ground contact, the practice of driving earth electrodes by hand hammering has been found to be unacceptable. Earth electrodes must be installed in drilled holes or mechanically driven in all situations and shall not be cut down under any circumstances.

In rocky areas, the soil resistivity is often high and earth rods cannot be installed by driving without causing breakage. Bored earths should be installed in these areas. This system is constructed by boring a hole into the ground to a suitable depth (often over 20m). Copper clad steel rods and/or bare stranded copper cable is then lowered into the hole and backfilled with slurry made from gypsum, bentonite clay and water.

It is important that all connections have proper preparation (e.g. scratch brushing and greasing) and are electrically robust.

If target earth resistance cannot be met after the addition of multiple earthing electrodes (typical say 10 to 12 rods) then the soil resistivity must be measured, and an earthing electrode design undertaken. Further information relating to the installation of earthing electrodes can be found in Work Category Specification WCS34.1 SWER Earthing Systems, Inspect and Test (690014) and Work Category Specification WCS34.2 Earthing Systems, Inspect and Test (690706).

5.5 Earthing Locations

Earthing system requirements may differ depending upon location. The three locations of main importance are:

- Special locations – Locations with high exposure rates and where people are likely to be wet and have no footwear. Locations within school grounds or within a children's playground, or within a public swimming pool area, or at popularly used beach or water recreation area, or in a public thoroughfare within 100m of any of the above named locations
- Frequented locations – Locations with high exposure rates. Any urban area associated within a city or town other than special locations
- Remote locations – Locations with low exposure rates. Any area other than special or frequented locations.

In *special locations* where there are very high occupancy rates of people or areas that are wet and have no series resistance (i.e., no shoes) a risk-based approach as per ENA Power System Earthing Guide (EG-0) Part 1: Management Principles (ENA DOC 025, 2022) or Standards Australia Overhead line design (AS/NZS 7000, 2016) shall be required to address step and touch potentials.

In *remote locations* the risk of hazardous step and touch potentials is low. Less stringent earthing may be applied in *remote locations* where there is proven high soil resistivity and target values are difficult to achieve economically, this may be considered based on a risk assessment as per ENA Power System Earthing Guide (EG-0) Part 1: Management Principles (ENA DOC 025, 2022) or Standards Australia Overhead line design (AS/NZS 7000, 2016).

Other situations that must be taken into account for earthing design are close proximity to continuous metallic objects such as:

- telecommunication cables and pits
- continuous metallic objects such as fences and pipelines, esp. in proximity to separate earthing installations.

Power system earth currents close to telecom cables and pits can create hazardous step and touch potentials for telecom workers and cause damage to cables and equipment. The general requirement is 2m separation from telecoms for CMEN and 15m separation for separate earths with individual earths to a maximum of 10Ω. Refer to Appendix A for a table giving clearances from different earthing systems and telecommunication's equipment.

Pools and spas can be an additional cause of concern due to the reduced contact resistance from being wet and having less chance of wearing shoes. The separation requirement around a common earthed asset for private swimming pools is 5m from any part of the earthing system. Unless the required separation to a swimming pool is determined in a detailed earthing design in accordance with Appendix B, the required separation for private swimming pools near separately earthed assets is 20 metres.

Conduction of fences and pipelines near separate earthing designs can cause hazardous transferred step and touch potentials. Impressed current cathodic protection schemes on pipelines can have the unintended side effect of causing corrosion of power system earths.

Conductive fences or rails should not be bonded to the earthing system of ground-mounted distribution equipment as this will extend the EPR hazard to outside the fenced area.

Bulk supply points and zone substations including those of Powerlink need to be treated as per *special locations* criteria.

6 Minimum Design Requirements

Due to the variability in site conditions, specific design requirements will be unique for each distribution earthing site. This Standard contains the **minimum** design requirement for standard distribution earthing sites and will be easily achievable in most areas of Energex. However, non-standard earthing designs may be required in certain situations, e.g. within 'high exposure locations and *special locations*'. In these cases, a risk based earthing design in accordance with ENA Power System Earthing Guide (EG-0) Part 1: Management Principles (ENA DOC 025, 2022) or Standards Australia Overhead line design (AS/NZS 7000, 2016) **shall** be undertaken to address step and touch potentials in the design process. The process is given in Appendix B.

6.1 Design Objective

The main objective of earthing design is to limit the risk of step, touch, and transfer potentials to proscribed limits as legislated through the Queensland Electrical Safety Act 2002 and associated codes of practices, guidelines, and standards.

The control method varies, but it largely comes down to these two central concepts

- Bonding of conductive parts to an effective (low impedance) earthing system, or
- Physical separation (Isolation).

The objective of this Standard is to provide a set of standard guidelines and best practices to ensure that earthing risks are minimized and mitigated where a hazardous situation is identified.

The design of the earthing system should ensure that:

- All metalwork and equipment able to be touched by a person standing on the ground (i.e., up to 2.4m above ground) are earthed
- Hazardous touch, step and transfer voltages are mitigated during fault conditions (50Hz or transient)

- A low impedance path is available for lightning, switching surges and 50Hz earth fault current to limit thermal and mechanical damage of plant and to ensure protective devices such as protection relays, fuses and surge arresters operate
- Minimal underground alterations are required if the installation is to be modified in the future
- Step & touch voltages comply with the legislated limits as prescribed in Electrical Safety Code of Practice 2020 –Works.

Earthing electrodes, joints and conductors should be designed to:

- ensure earth fault currents are conducted to earth without damage to the earthing components
- minimise the possibility of mechanical damage
- avoid inadvertent interference
- minimize chemical deterioration.

It is important to ensure three-phase loads are balanced to minimise the out-of-balance current flow in the neutral which also flows to earth. Harmonic currents may also cause an increase in neutral current which flows to earth.

7 Distribution Earthing Systems

7.1 Low Voltage Multiple Earthed Neutral (MEN) System

To achieve a low resistance between the neutral and ground, the low voltage neutral in a MEN system shall be earthed at the following locations:

- the LV neutral terminal of the transformer
- the end of radials (main cables)
- every 5th service pillar/pit or pole or every 250 “cable route metres”, whichever is the lesser distance
- switches (link pillars or disconnect links on poles).

The local low voltage earth shall be less than 30Ω disconnected and 10Ω when in-service, connected in parallel with the area MEN.

Also, inside the customer’s installation, the neutral conductor is connected to a local earth at the customer’s switchboard. Consequently, all metalwork of appliances, tools etc. are also connected to the low voltage neutral. It is therefore essential that the neutral conductor be kept at, or close to earth potential.

7.3 The Common Multiple Earthed Neutral (CMEN) System

The Common Multiple Earthed Neutral System (CMEN system) is an extension of the MEN system whereby the low voltage neutral conductor (and hence the low voltage earthing system) is considered to be of low enough resistance to remote earth that the high voltage earthing system (transformers, zone substations, poles carrying exposed metalwork etc. capable of being energised at high voltages) is allowed to be connected to it. The CMEN system uses the low voltage neutral conductor as the return path for both low and high voltage fault currents. A very low resistance to earth for the neutral is required to ensure HV fault currents do not cause unacceptably high voltages on the LV network.

Within Energex the conditions required for creating a CMEN system are:

- less than 1Ω resistance between the network neutral and earth (i.e., 'connected' resistance), and
- a minimum of three transformers with LV neutral interconnected.

The three transformers connected must have a large number of earths (typically more than 100 electrodes). If there were only a few earth rods, although achieving less than 1Ω to earth at the time of testing, problems may arise later due to resistance increasing with seasonal soil moisture variation. The large number of electrodes required for the formation of CMEN system is based around Appendix B of Standards Australia Substations and high voltage installations exceeding 1 kV a.c. (AS 2067, 2016).

There is also the additional general requirement that individual earth resistance (i.e., disconnected from the network neutral) must be less than 30Ω for pole-mounted plant and less than 10Ω for ground-mounted plant. The lower earthing resistance for ground-mounted plant is because there is a greater chance of the equipment being touched. Refer to Figure 2 showing earthing requirements for a typical CMEN earthing system at a pole.

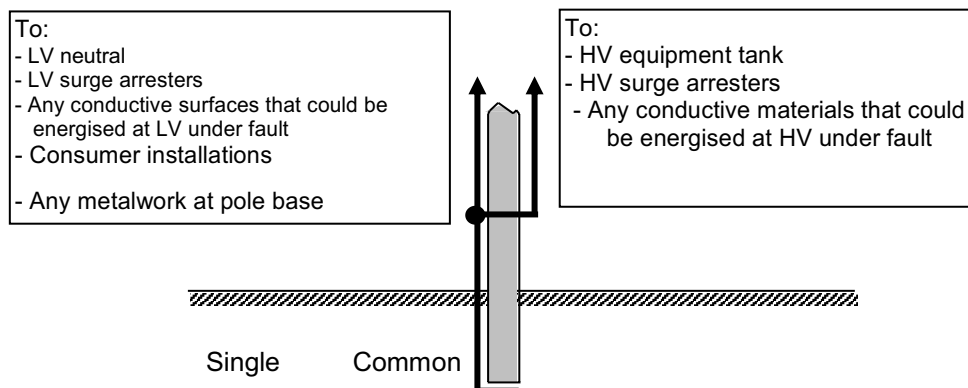

Figure 2: Typical CMEN Earthing System (illustrated for overhead network)

In high load density areas, conditions generally allow a CMEN system. It is typically in lower load density, more sparsely populated areas where conditions for CMEN are not achievable and separately earthed HV and LV is required. The CMEN system is sometimes referred to as a 'bonded' or 'common' earthing system as the high voltage and low voltage earthing systems are bonded together.

The advantages of using the CMEN system are:

- only one earthing system need be installed at distribution transformers
- step and touch potential problems are reduced and

- earth potential rise (EPR) problems associated with electrical plant in close proximity to telecommunications plant are also reduced.
- Earth fault currents are higher, so upstream protection can clear the fault quicker.

The CMEN system is the preferred method by which to earth Energex's distribution network, however, should only be employed in areas where there is an abundance of low voltage interconnections and a low overall resistance to ground is achievable.

7.4 Separately Earthed System Consisting of a Low Voltage Multiple Earthed Neutral (MEN) System and High Voltage Earth

In cases where the conditions required for CMEN earthing set out in Section 7.2 cannot be met, the high voltage earth must be kept separate from the LV MEN system. Typically, this would occur in rural areas with low load density. Separation is required to ensure high voltage earth faults, lightning impulses or switching surges (e.g., conducted to earth through surge arresters) do not cause excessive EPR on the LV system.

The MEN system is used for the low voltage network. The neutral conductor is used as a low resistance return path for low voltage fault currents only. The general requirement is that the resistance to earth of the connected LV MEN neutral of the network must be less than 10Ω and the LV individual earth resistance (i.e., disconnected from the network neutral) must be less than 30Ω , except for the transformer neutral earth which requires 10 ohms.

The high voltage earthing system provides an earth return path for plant and equipment capable of being energised by the high voltage system (e.g. surge arresters, transformer tank). The general requirement is that the HV individual earth resistance must be less than 30Ω for pole-mounted plant and less than 10Ω for ground-mounted plant. The lower earthing resistance for ground-mounted plant is because there is a greater chance of the equipment being touched.

To ensure that the potential rise during high voltage faults does not cause a safety hazard to the operator or the general public, the high voltage earth is always insulated and separated from the low voltage earth in a separately earthed system, as shown in Figure 3 and Figure 4 below.

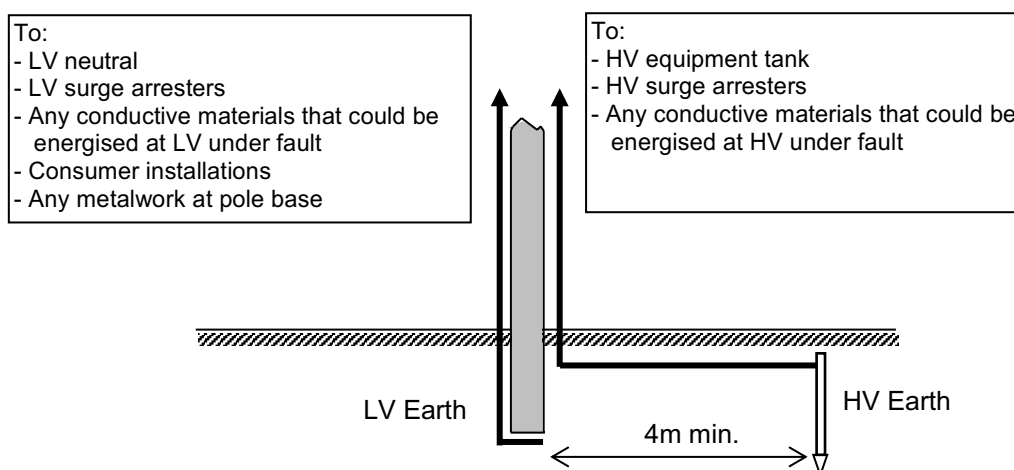

Figure 3: Typical Separate Earthing System for Overhead Network

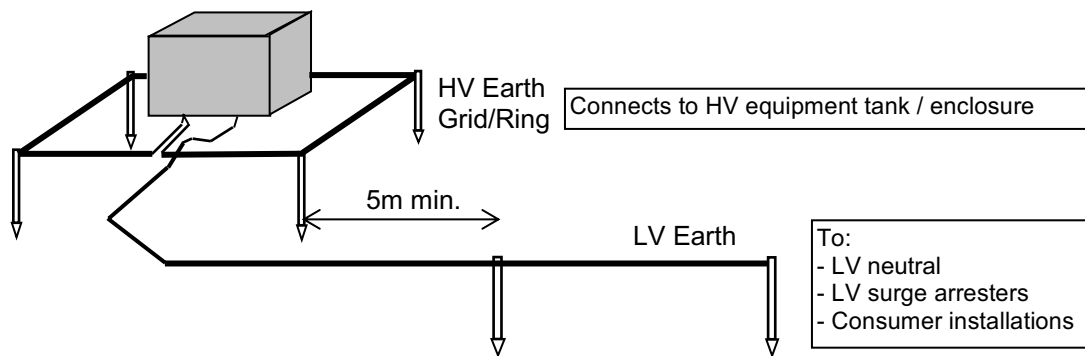

Figure 4: Typical Separate Earthing System for Underground Network

Note: The 5 metre minimum clearance zone is measured from the edge of the plinth, clearance zone to be maintained free from metallic objects, buildings, and structures, including foundations. The clearance zone shall be road reserve or an easement to prevent encroachment and turfed or landscaped if necessary, with mulched beds and shrubs.

In a Separate Earthing System, the high voltage earth shall always be insulated and separated from the low voltage MEN system.

7.5 Accessible Metalwork

The general requirement is to ensure that any accessible metalwork (i.e., conductive surface able to be touched by persons) does not become energised at a hazardous voltage. Accessible metalwork includes:

- operating handles for air break switches and cable guards on poles
- equipment cabinets.

For situations with CMEN, the general requirement is that accessible metalwork should be bonded to the CMEN.

For separately earthed situations on an overhead network, the accessible metalwork on poles should not be bonded to the HV earth (but should be bonded to the LV earth/neutral if present). For separately earthed equipment cabinets on an underground network, the frame should be bonded to the HV earth and the earth mat/grading ring.

7.6 Single Wire Earth Return (SWER) Earthing

The Single Wire Earth Return system requires separate and distinct high voltage and low voltage earthing systems.

SWER systems consist of a single isolating transformer (typically 100 - 150kV.A, 5 - 8A), and a number of individual SWER distribution transformers. The isolating transformer carries all the load of the SWER scheme connected to it. The primary winding of the isolating transformer is connected between two phases of the conventional 11kV (or 33kV) system. The secondary winding has one terminal forming the high voltage (Single Wire) of the SWER line (typically 12.7kV) and the other is connected to earth. The individual distribution transformers have one terminal connected to the high voltage line, and the other to earth. The earth acts as the return conductor back to the isolating transformer to complete the circuit (Earth Return). This is illustrated in Figure 5 below.

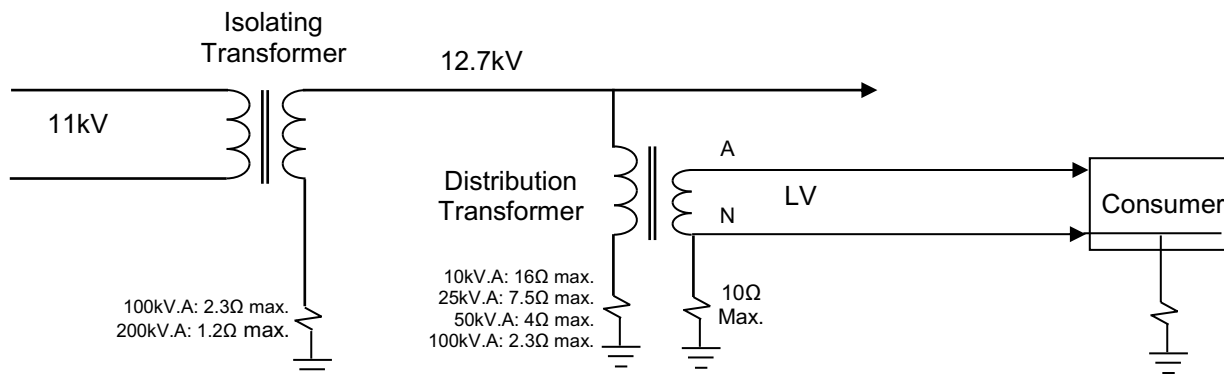

Figure 5: SWER Earthing System

In normal three-phase systems, earthing of 11kV equipment is merely a protective measure and current flows in the earth circuit only for the duration of a fault. However, in the case of a SWER system, the 12.7kV earthing installation carries the load current of the circuit as well as any fault current. This aspect brings the earthing system of the SWER line into greater prominence than that of the conventional line. The maximum SWER earth lead (i.e., HV earth) voltage under operating conditions is not to exceed 20V.

The safe operation of any electricity distribution system necessitates the maintenance of low resistance earths in order to ensure that protective devices will operate under fault conditions. Hence, within certain limits, the SWER system presents no greater problem than is encountered for the conventional system, assuming that no increase in resistance occurs owing to the passage of load current. The resistance to ground of the high voltage earthing system shall not exceed the values shown in Figure 5.

The low voltage earthing system for the SWER system provides the earth return path for the low voltage and is separate from the high voltage earthing system. In general, SWER systems will only have one customer at each transformer. Thus, for each customer installation, there will only be a low voltage earth electrode system at the transformer and an earth electrode at the customer's premises earthing the low voltage neutral. Hence, the resistance to ground of the low voltage earthing system at the transformer shall not exceed 10Ω.

The SWER system is a separately earthed system. The high voltage and low voltage earth cables shall be insulated and there shall be a minimum separation of 5m between the high voltage and low voltage earth electrodes.

7.7 Transmission and Sub-Transmission Earthing

For sub-transmission (33kV) and transmission (110/132kV), it is important to ensure lightning impulses on overhead earthwires and any earth fault current, switching surges or lightning impulses from equipment do not cause excessive EPR on the LV system. Consequently, 33kV earth electrodes must be separated from LV earth electrodes by more than 5m. LV earth downloads must be insulated and kept separated from sub-transmission and transmission earths.

The low voltage earth cables shall be insulated and separated on the pole from the 33kV earths.

33kV OHEWs (overhead earthwires) are earthed with a maximum of 30Ω resistance.

LV cables should generally not be run on poles or structures with 110/132kV overhead circuits. Where this does occur, the LV earth electrodes should be separated from any 110/132kV earthing electrodes in the ground by a minimum 20m.

8 Overhead Distribution Earthing Philosophy and Practice

8.1 Pole-Mounted Distribution Transformers

8.1.1 CMEN System

The CMEN system is the preferred method, however, should only be employed in areas where there is an abundance of low voltage interconnections and a low overall resistance to ground is achievable.

Where a CMEN system of earthing is used, the in-service resistance between the neutral conductor of the distribution network and ground at any location shall not exceed 1Ω.

At the transformer, the CMEN system of earthing shall have the following connected to it, as shown in Figure 6:

- transformer tank and any high voltage surge arresters
- low voltage neutral and any low voltage surge arresters
- any metal work such as cable sheaths and
- a local earthing system with a disconnected resistance to ground not exceeding 30Ω.

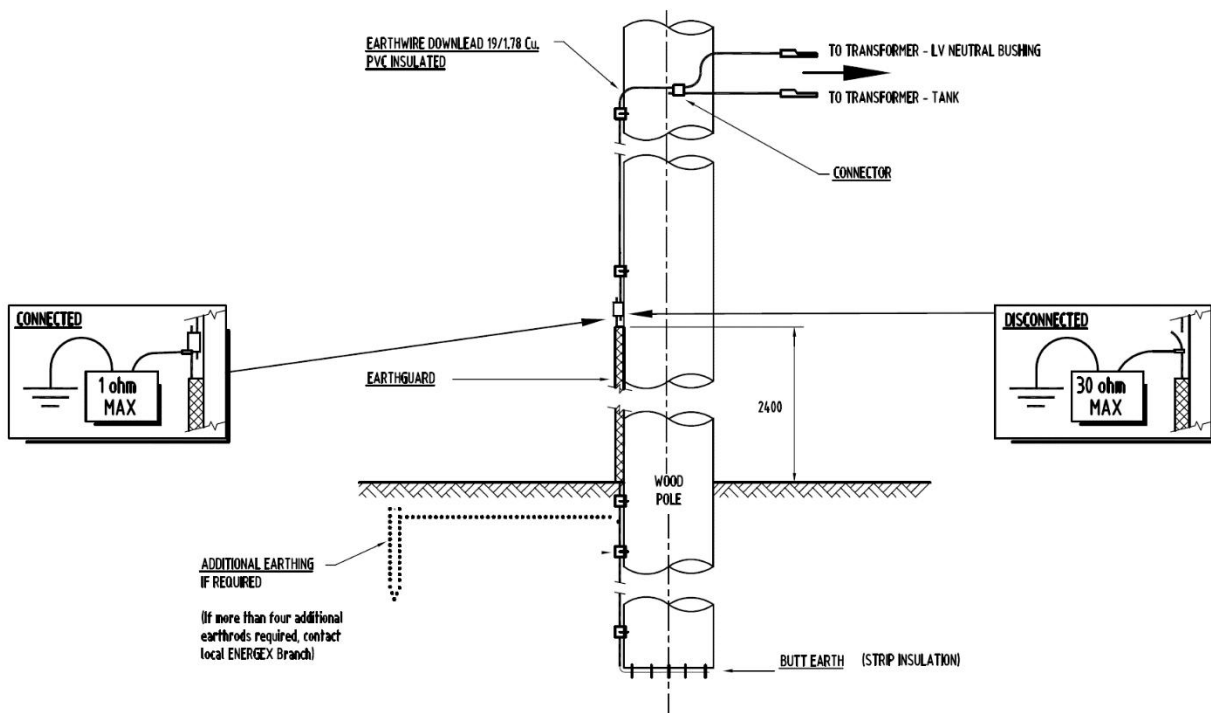

Figure 6: Pole Transformer with CMEN Earthing System

8.1.2 Separately Earthed High Voltage and Low Voltage (MEN) System

Two separate and distinct earthing systems shall be provided if the requirements for CMEN cannot be met. The high voltage and low voltage earth downloads shall be PVC-insulated (or similar) and the high voltage and low voltage earthing electrodes shall be separated by a minimum of 4m. Refer to Figure 7 for typical pole mounted transformer with separate earthing.

The low voltage earth is used for earthing the low voltage neutral, metalwork associated with the low voltage and the low voltage surge arresters. The disconnected resistance to remote earth of the individual low voltage earthing system at the transformer shall not exceed 10Ω and the resistance to earth of the connected LV neutral must be less than 10Ω.

The high voltage earthing point is used for earthing all metalwork associated with the 11kV system including the transformer tank and the 11kV surge arresters. The general requirement is that the disconnected resistance to remote earth of the separate high voltage earthing system shall not exceed 30Ω for a pole transformer installed on a timber pole.

High Voltage earths are permitted above 30Ω subject to a risk assessment taking into account low contact exposure to the earth by persons and the cost/practicality of achieving a low earth resistance in high soil resistivity.

One case of a risk-assessed situation where higher earthing resistance is acceptable is a *remote* and isolated area with proven high soil resistivity supplied by a transformer rated at 63kV.A or less, where the disconnected resistance to ground of an individual separate low voltage earthing installation may be up to 30Ω. A further requirement for this case is that LV mains below bare HV must be insulated with 0.6/1kV insulation.

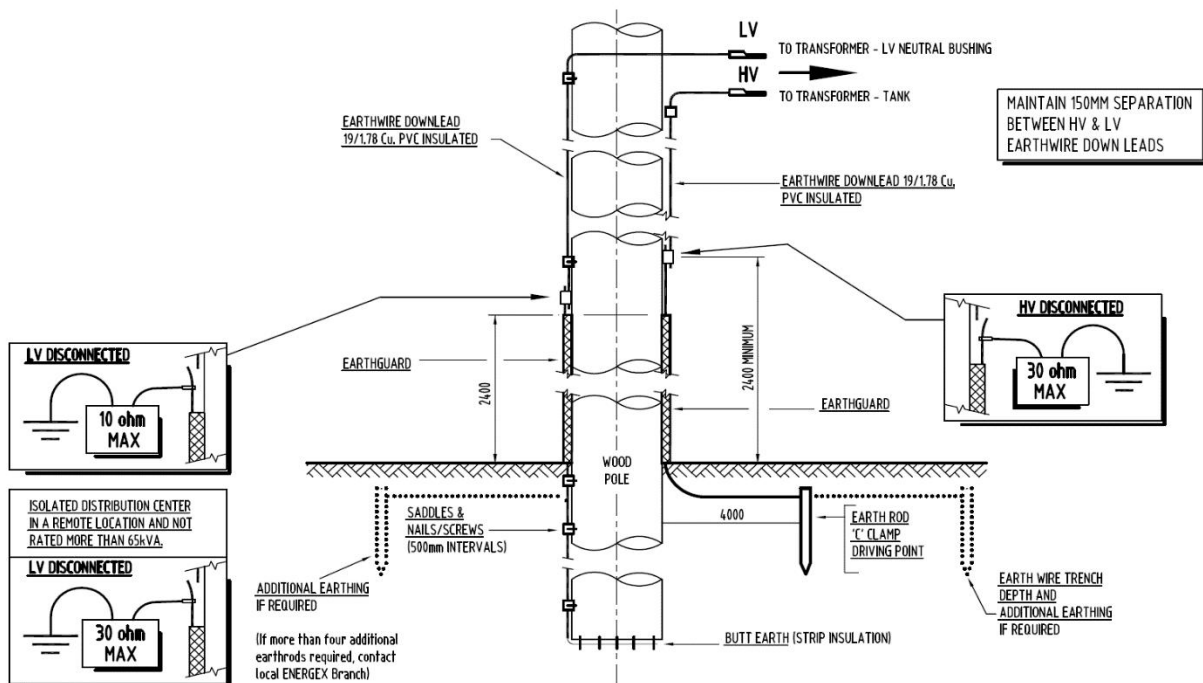

Figure 7: Pole Transformer with Separate Earthing System

8.1.3 Single Wire Earth Return (SWER) Earthing

At SWER distribution transformers, two separate and distinct earthing systems must be provided, as illustrate in Figure 8 below.

Standard for Distribution Earthing

The high voltage SWER earthing system is used for earthing all metalwork associated with the high voltage including the transformer tank, high voltage earth bushing and high voltage surge arresters. The resistance to ground of the high voltage earthing system is dependent on transformer size as shown in Figure 5 and must consist of:

- At least two earthing conductors with maximum separation on the structure, connected to an interconnected earthing system consisting of at least three earth electrodes spaced not less than 3m apart. The earthing arrangement shall be such that in the event of an earthing conductor being severed between two earth electrodes that at least one earth path remains. (Should the earth connection be broken, the earth lead becomes effectively energised to the SWER line voltage, 12.7kV)
- Earthing cables up to 2.4m from ground level shall be insulated with 0.6/1kV grade insulation and mechanically protected
- No disconnectable joints in the earthing conductors between the high voltage earth bushing and the earth electrodes.

The maximum SWER earth lead (i.e., HV earth) voltage under operating conditions shall not exceed 20V.

The low voltage earth is used for earthing the low voltage neutral, metalwork associated with the low voltage and the low voltage surge arresters. The resistance to ground of an individual low voltage earthing system shall not exceed 10Ω.

Note: The high voltage and low voltage earthing cables shall be insulated, and high voltage and low voltage earth rods shall be separated a minimum of 5m apart.

The limits on individual low voltage earths may be raised subject to a risk assessment and taking into account low contact exposure to the earth by persons and the cost/practicality of achieving a low earth resistance in proven high soil resistivity; however, the overall resistance to ground of the interconnected low voltage neutral must not exceed 10Ω at any point.

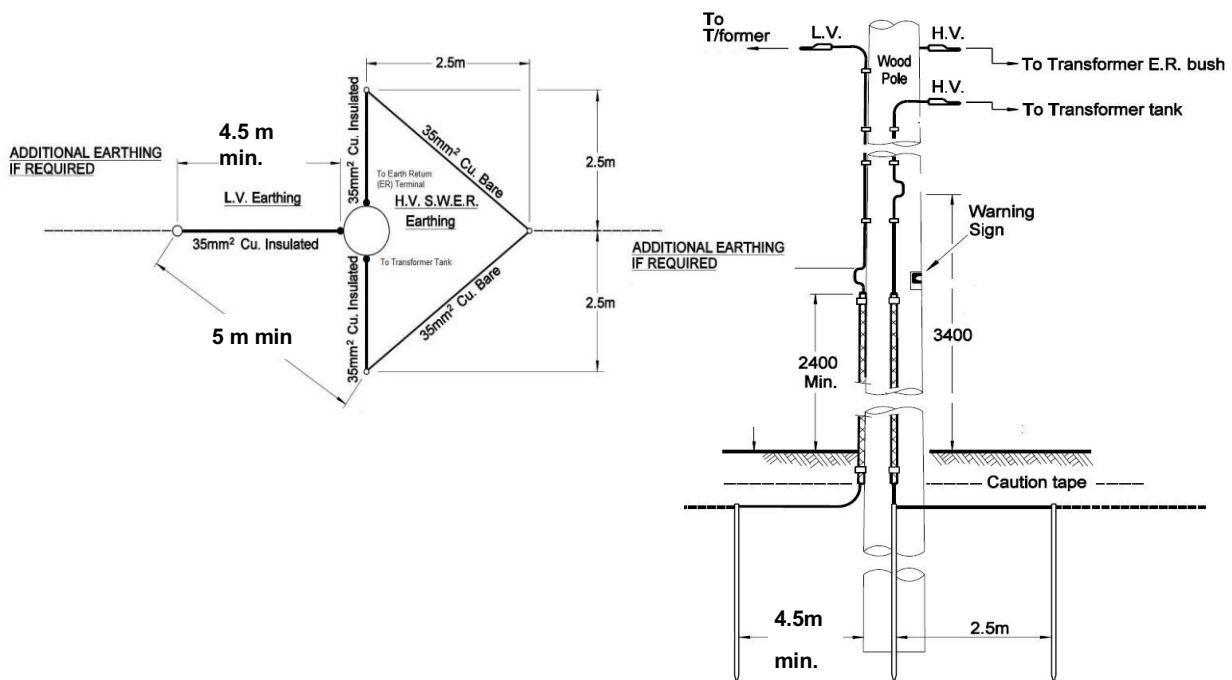

Figure 8: SWER Transformer Earthing

8.2 Timber Distribution Poles

8.2.1 CMEN System

The 11kV high voltage and 415V low voltage earthing systems shall be tied together with an in-service resistance of the neutral to earth of less than 1Ω . The local disconnected earth resistance shall be less than 30Ω .

8.2.2 Separately Earthed High Voltage and Low Voltage (MEN) System

Where the CMEN requirements cannot be met, separate earthing is required.

11kV high voltage earths shall be bonded to the local high voltage earth with a disconnected resistance to earth of less than 30Ω . The 11kV earth must be separated from the LV earth. The resistance to earth of the disconnected LV neutral must be less than 30Ω and the resistance to earth of the connected LV neutral must be less than 10Ω .

Note: On any timber pole, the high voltage and low voltage earth downleads shall be PVC insulated (or similar) and separated by a minimum of 150mm on the pole. Furthermore, the high voltage and low voltage earthing electrodes shall be separated by a minimum of 4m.

8.3 Conductive Distribution Poles (Concrete and Steel)

8.3.1 General

This section addresses conductive distribution poles with LV 415V and/or HV 11kV installed. It does not address poles with higher voltages installed. As concrete or steel poles are conductive structures, all earthing systems attached to the pole will be inherently bonded together unless specific care is taken. As such, caution is required when conductive poles are installed in separately earthed areas.

8.3.2 MEN

For conductive poles with LV only, the poles must have a disconnected resistance to ground of less than 30Ω and the connected resistance to ground of the LV neutral must be less than 10Ω . The LV earth must be bonded to the MEN and the conductive pole. If the pole butt is electrically insulated from ground, then a separate earth stake shall be connected to the pole.

8.3.3 CMEN System

In general, use of conductive poles supporting HV mains should be avoided unless a CMEN system can be established.

In a CMEN system, all conductive poles must have a disconnected resistance to ground of less than 30Ω , and an in-service neutral resistance to earth at any point of less than 1Ω , as shown in Figure 9.

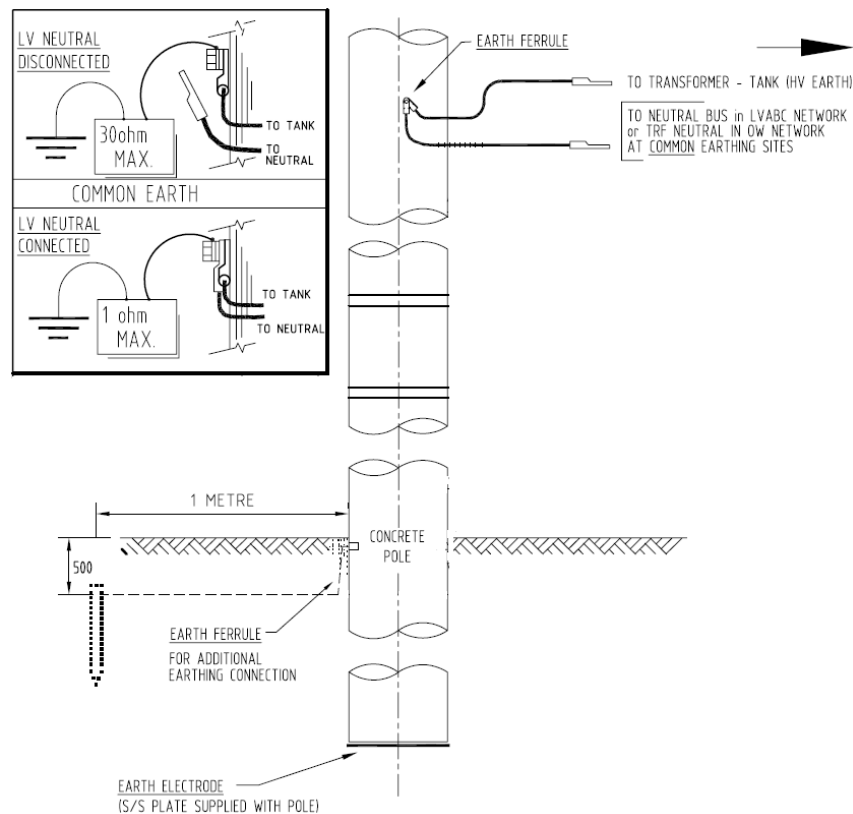

Figure 9: Conductive Pole with 11kV and LV, CMEN Earthing

For 11kV conductive poles with no low voltage neutral present, a separate earth wire is required to be strung on each pole to a nearby low voltage neutral. The conductive pole must have a disconnected resistance to ground of less than 30Ω and an in-service resistance to earth at any point of less than 1Ω .

If CMEN requirements cannot be achieved then, the installation must be treated as if it were in a separately earthed area as detailed in 8.3.4 below.

8.3.4 Separately Earthed High Voltage and Low Voltage (MEN) System

Where the CMEN requirements cannot be met, separate earthing is required.

Separately earthed conductive poles should be avoided as they increase the risk of hazardous touch potentials. In *special and frequented locations*, step and touch potentials around conductive poles must be addressed, possibly using a risk-based approach. Pole base insulation, grading rings or other methods of mitigation may be required in addition to the earthing requirements that follow.

Conductive poles shall only be used in the separately earthed system where low voltage earths are NOT in direct contact with the pole as per the following:

- Non-conductive timber or composite fibre low voltage crossarms
- LV ABC with no MEN downlead
- LV earth insulated inside UV-stabilised conduit.

In circumstances where the low voltage neutral is required to be earthed on a conductive pole, the low voltage earth wire must be totally insulated from the pole by installing it in a UV-stabilized conduit. The HV earth must be separated from the LV earth. As the pole is often connected to the HV earth (e.g., via the frame of transformer), the low voltage earth electrode is to be installed no closer than 4m from the pole. Figure 10 illustrates separate earthing requirements for a conductive pole with HV and LV earths.

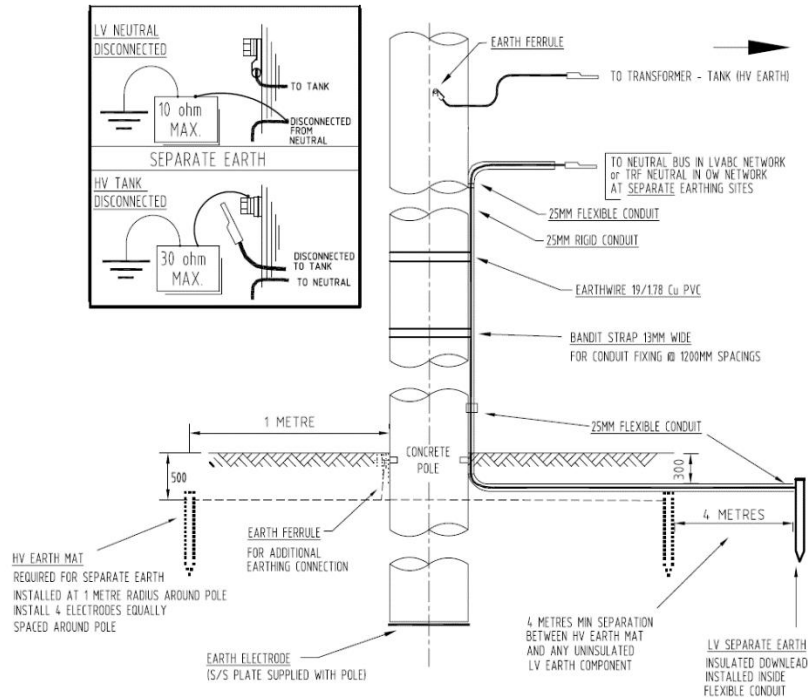

Figure 10: Conductive Pole with Separate Earthing

8.4 33kV Overhead Earthwire (OHEW)

8.4.1 General

All new 33kV lines will have an OHEW or OPGW (optical fibre in ground wire) installed above. This serves to protect phase conductors and nearby substation equipment against direct lightning strikes and associated overvoltages. It is important to ensure that excessive lightning transients on the 33kV OHEW earthing system are not coupled onto lower voltage earthing systems. The configuration of the OHEW earthing system is dependent on the type of pole it is mounted on, and the other plant situated on the pole.

33kV underground cable terminations shall not be installed on the same pole as any distribution plant, MEN earth or 11kV cable termination.

8.4.2 Timber Poles

8.4.2.1 General

On timber poles, the 33kV OHEW shall be connected to earth via a dedicated copper downlead at every pole where achievable. To limit tracking under fault conditions, the gain base of any 33kV or 11kV insulators installed on the pole (VDR or VOR constructions) shall **NOT** be bonded to this down lead. The local 33kV OHEW earth shall be a maximum of 30Ω.

On poles containing 11kV or 33kV pole-mounted plant, 11kV and/or LV earths the 33kV OHEW downlead shall **NOT** be connected to earth at this pole and instead bonded at the next available pole.

8.4.2.2 CMEN

On timber distribution poles containing common 11kV and/or LV earths, where running a 33kV OHEW downlead cannot be avoided, the 33kV OHEW shall be earthed separately from the 11kV and LV earths. The 33kV and CMEN earth conductors shall be PVC insulated (or similar) with maximum separation on the pole (150mm minimum) and the electrodes separated by a minimum of 4m.

8.4.2.3 Separately Earthed

On timber distribution poles containing separate 11kV and/or LV earths, where running a 33kV OHEW downlead cannot be avoided, the 33kV OHEW downlead may be connected to the 11kV earth whilst maintaining a minimum 4m separation from the LV earth.

8.4.3 Conductive Poles

8.4.3.1 General

As concrete and steel poles are conductive, a 33kV OHEW will be inherently bonded to earth via the structure.

Conductive poles with a 33kV earth have increased risk of hazardous touch potentials. In *special* and *frequented locations*, step and touch potentials around conductive poles must be addressed, possibly using a risk-based approach. Pole base insulation, grading rings or other methods of mitigation may be required in addition to the earthing requirements that follow.

8.4.3.2 CMEN

Avoid using conductive poles with 33kV OHEW, 11kV and LV earths all joined to one CMEN earth as lightning overvoltages can be impressed on the LV neutral. Note that the earths can be inadvertently connected via the frame of equipment which is in contact with the conductive pole. (If this configuration cannot be avoided, then connect 33kV, 11kV and LV earths together to a local disconnected earth resistance of 30 Ω maximum and a connected resistance to earth of 1 Ω maximum).

8.4.3.3 Separately Earthed

For conductive poles with a 33kV Overhead Earth Wire (OHEW), the 33kV OHEW is bonded to the pole. The 11kV earth must also be bonded to the pole. The 33kV earth, 11kV earth and the pole must all be connected to a local earth with a resistance of less than 30 Ω .

Conductive poles shall only be used in the separately earthed system where low voltage earths are NOT in direct contact with the pole as per the following:

- Non-conductive timber or composite fibre low voltage crossarms
- LV ABC with no MEN downlead
- LV earth insulated inside UV-stabilised conduit.

In circumstances where the low voltage neutral is required to be earthed on a conductive pole, the low voltage earth wire must be totally insulated from the pole by installing it in a UV-stabilized conduit.

The resistance of the disconnected LV neutral to ground must be less than 30Ω and the resistance of the connected LV earth must be less than 10Ω . The LV earth electrodes must be separated from the pole (which is also bonded to the 33kV and 11kV earths) by a minimum of 4m.

8.5 Steel Crossarms

8.5.1 Wooden Poles

When installed on wooden poles, steel crossarms shall not be bonded to earth. The primary reason for this configuration is to prevent outages caused by wildlife bridging phase conductors to the earthed steelwork.

8.5.2 Conductive Poles

Steel crossarms on conductive poles will be inherently earthed to the reinforcement of the pole. No further bonding of the cross arm to the pole is necessary.

8.6 HV Pole-Mounted Equipment (Recloser, Regulator, Enclosed Switch)

8.6.1 General

33kV or 11kV pole-mounted equipment shall be connected to the local high voltage earth, as the equipment is capable of being energised by high voltage conductors.

Arrangements for earthing of control/meter boxes vary according to the manufacturer.

No 33kV underground cable termination, 33kV recloser or any 33kV OHEW downlead shall be on the same pole as any distribution plant.

8.6.2 CMEN System

33kV or 11kV plant earths shall be bonded to the CMEN earthing system with a disconnected resistance to ground not exceeding 30Ω and with an in-service connected resistance to earth at any point of less than 1Ω . Any LV neutral, control/meter box or radio antenna base shall also be connected to this same earth. Refer Energex Overhead Construction Manual Section Page 607 (HVE2) and Page 616 (HVE4).

8.6.3 Separately Earthed High Voltage and Low Voltage (MEN) System

The separately earthed system should only be used where the CMEN requirements cannot be met.

The equipment must only be connected to the local HV earthing system with a resistance to ground not exceeding 30Ω . The HV earth downlead must be separated from the LV earth downlead on the pole and the 33/11kV earth electrodes must be separated from the LV earth electrodes by a minimum of 4m.

Control/meter box earthing is dependent on the manufacturer. The earthing systems are either:

- the control/meter box is connected to the 'LV' earthing system, or
- for certain older Nulec models (refer Energex Overhead Construction Manual Section 7 Page 615 (HVE3)), the control/meter box is connected to the HV earth and there is an isolation transformer for signals to the HV plant.

Generally, control boxes will not be accessible from the ground (a short ladder is required). However, where the control box can be operated from the ground, then a grading ring shall be installed around the pole and connected to the LV earthing system. Refer Energex Overhead Construction Manual Section 7 page 606 (HVE1).

The radio antenna base is to be connected to the HV earth if mounted above or alongside the HV mains. If below, then antenna base is connected to the 'LV' earth.

8.7 Distribution Equipment on Transmission Poles

For the particular case where distribution equipment is mounted on 110/132kV transmission poles, the design principles listed below apply.

- No distribution transformer or any 11kV plant shall be attached to the transmission pole, hence the absence of 11kV earthing
- No low voltage earthing shall be installed at the base of the pole
- On conductive poles, alternative earthing systems shall be employed to ensure that the step and touch potentials during a high voltage fault at the pole comply with the requirements of Standards Australia Overhead line design (AS/NZS 7000, 2016) and ENA Power System Earthing Guide (EG-0) Part 1: Management Principles (ENA DOC 025, 2022), e.g., grading ring, application of insulation to pole base/cable guard in special or frequented locations
- 33kV underground and transmission network has a common earth.

8.8 Metal Work at Ground Level

8.8.1 Pole Nails/Stakes and Rebutted Pole Steel Sleeves

Pole nails/stakes and rebutted pole steel sleeves are not required to be earthed (and it is preferred that they are not earthed to inhibit corrosion between the galvanized steel and copper earthing conductors). Due to the nature of their installation, pole nails/stakes and rebutted pole steel sleeves will be inherently earthed. Earth downleads shall be kept insulated from pole nails/stakes and rebutted pole steel sleeves.

8.8.2 Metallic Cable Guards Protecting Low Voltage Cables

Unless the low voltage cable is fully installed within a conduit behind the cable guard, Energex requires that metallic cable guards protecting low voltage cables be earthed.

Metallic cable guards shall be connected to earth with a resistance of 30Ω maximum. Cable guards should be connected to the LV neutral, where present.

8.8.2.1 CMEN System

Metallic cable guards shall be connected to the 11kV and LV CMEN earth with a disconnected resistance of less than 30Ω and a connected LV neutral to earth resistance of less than 1Ω.

8.8.2.3 Separately Earthed High Voltage and Low Voltage (MEN) System

Metallic cable guards over LV cables shall be separately earthed (i.e., separate from any HV earthing) with a disconnected resistance of less than 30Ω . Additionally, if a low voltage earth down lead exists on the pole, the metallic cable guard shall be connected to the low voltage earthing down lead. The high voltage and low voltage earth conductors shall be PVC insulated (or similar) with maximum separation on the pole and the high voltage and low voltage earthing electrodes shall be separated by a minimum of 4m. Metallic cable guards must not be connected to HV surge arresters or any part of the high voltage earthing system. In general, metallic cable guards shall not be mounted on conductive poles (e.g., Concrete or steel) in separately earthed areas.¹

The HV earth downlead must be kept separated from the metallic cable guard (i.e., not pinched under the guard).

8.8.3 Metallic Cable Guard Protecting High Voltage Cable

8.8.3.1 General

Earthed metallic cable guards are required to protect high voltage cables. Cable guards shall be connected to the LV neutral, where present.

8.8.3.2 CMEN System

HV cable sheath, HV surge arresters, metallic cable guard and LV neutral shall be connected to the CMEN earthing system with a disconnected resistance to ground not exceeding 30Ω and a connected LV neutral resistance to earth of less than 1Ω , as shown in Figure 11 below.

¹ Where this is unavoidable, such as retrofitting a cable to an existing concrete HV pole, connect the cable guard to the HV earth rather than the LV earth. This is to ensure the cable guard and the pole is at the same potential. Ensure there is adequate insulation between LV cable and cable guard.

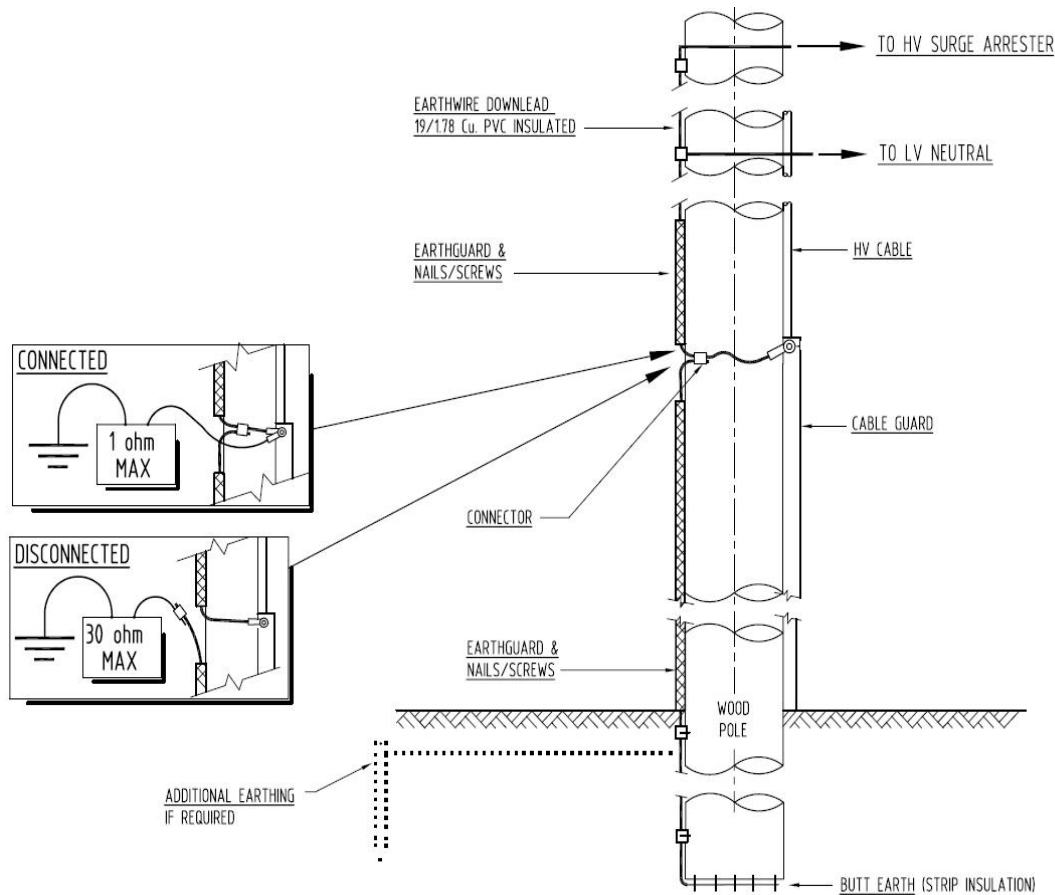

Figure 11: Metallic Cable Guard with CMEN Earthing

8.8.3.3 Separately Earthed High Voltage and Low Voltage (MEN) System

Metallic cable guards over HV cables shall be separately earthed (i.e., separate from any HV earthing) with a disconnected resistance of less than 30Ω. If low voltage exists on the pole, the metallic cable guard shall be connected to the low voltage neutral via the earthing download. The high voltage and low voltage earth conductors shall be PVC insulated (or similar) with maximum separation on the pole and the high voltage and low voltage earthing electrodes shall be separated by a minimum of 4m, as illustrated in Figure 12 below.

HV surge arresters and HV cable sheaths must not be connected to metallic cable guards at separately earthed sites. The HV earth download must be kept well separated from the metallic cable guard (i.e., not pinched under the guard).

High voltage cables under metallic cable guards shall be insulated to prevent the cable guard from becoming live. For XLPE cables, the polyethylene outer sheath provides the insulation. For older jute covered cables, split PVC conduit shall be installed around the cable to provide insulation.

In general, metallic cable guards shall not be mounted on conductive poles (e.g., concrete or steel) in separately earthed areas.²

² Where this is unavoidable, such as retrofitting a cable to an existing concrete HV pole, connect the cable guard to the HV earth rather than the LV earth. This is to ensure the cable guard and the pole is at the same potential.

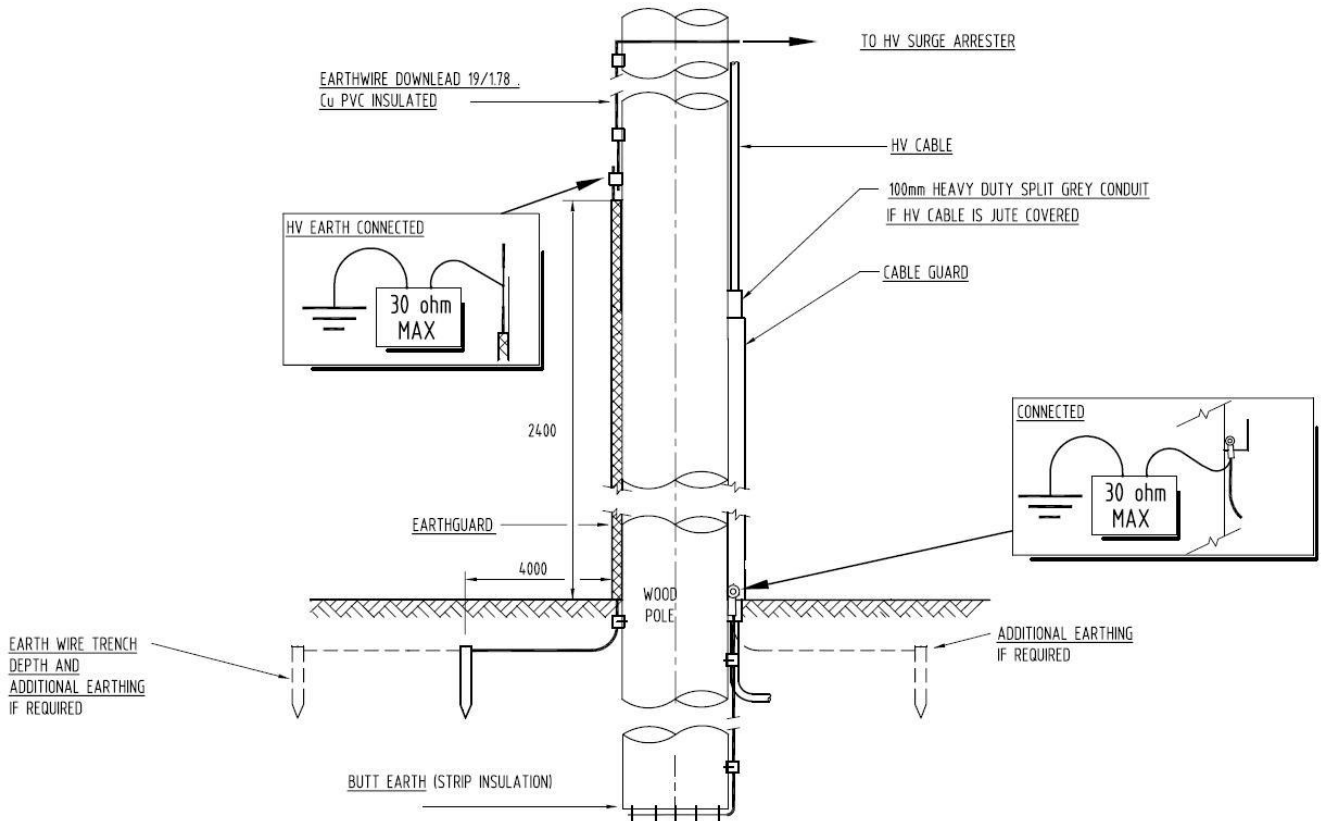

Figure 12: Metallic Cable Guard with Separate Earthing

8.8.4 Air Break Switch (ABS) Handles and Metallic Down Rods

8.8.4.1 General

The down rods of air break switches are fitted with two insulated sections, one below and one above the location of the low voltage mains. Older types have hardwood timber sections that reach below the level of the low voltage mains. This is to ensure the down rod cannot accidentally be contacted by high voltage lines. Therefore, the air break switch handles and metallic down rods, as well as any metallic cable guards, shall be bonded together and connected to earth with a resistance of 30Ω maximum. These metallic items shall be connected to the LV neutral, where present.

8.8.4.2 CMEN system

The metallic down rods, air break switch handle, LV neutral and any HV earth shall be connected to the CMEN earthing system with a disconnected resistance to ground not exceeding 30Ω and a connected LV neutral resistance to earth of less than 1Ω, as shown in Figure 13 below.

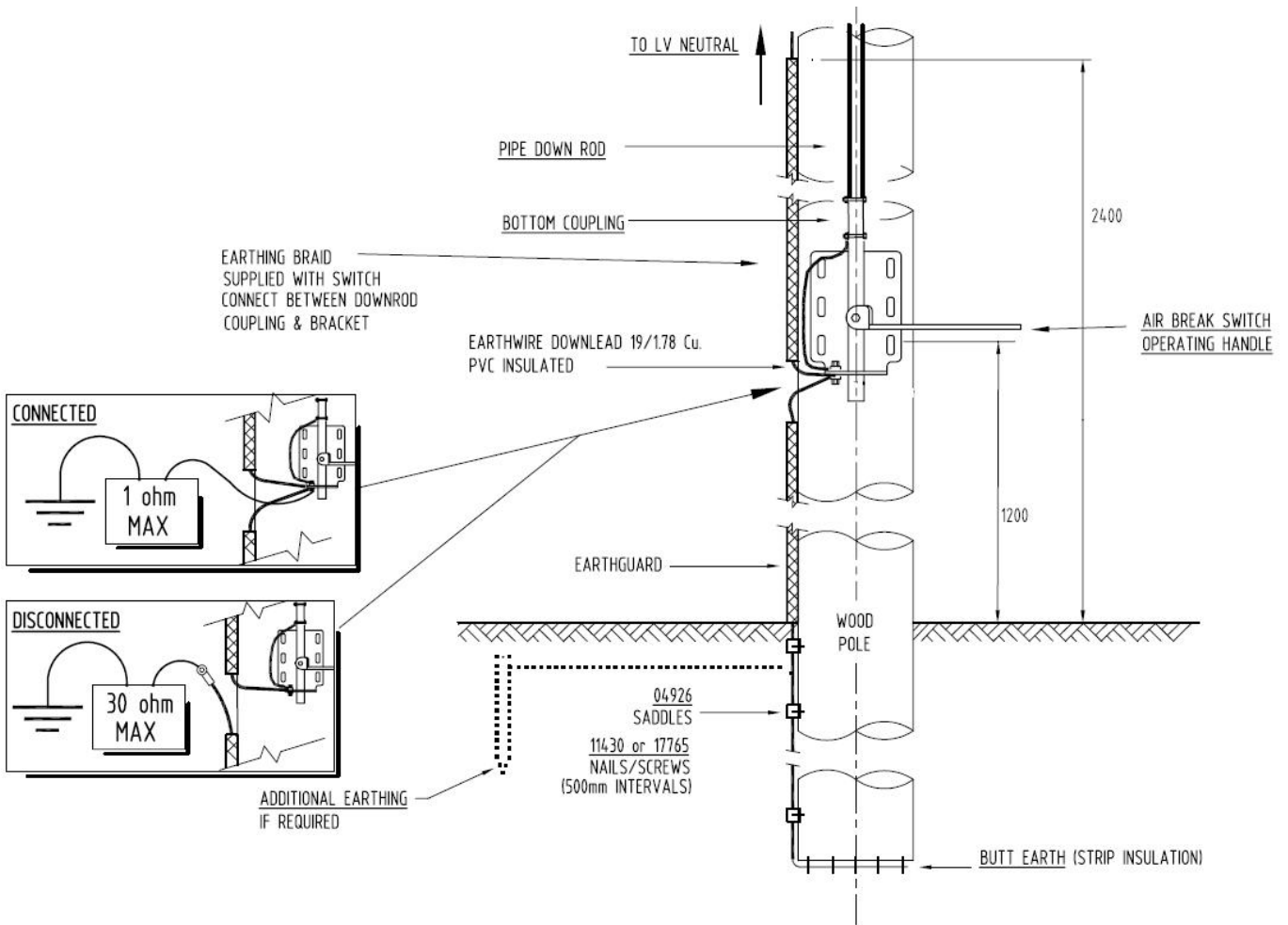

Figure 13: Air Break Switch Handle with CMEN Earthing

8.8.4.3 Separately Earthed High Voltage and Low Voltage (MEN) System

Metallic components (e.g., Air Break Switch handles, metallic down rods and metallic cable guards) shall be separately earthed (i.e., separate from any HV earthing) with a disconnected resistance of less than 30Ω, as shown in Figure 14 below. Additionally, if a low voltage earth downlead exists on the pole, these metallic components shall be connected to it. The high voltage and low voltage earth conductors shall be PVC insulated (or similar) with maximum separation on the pole and the high voltage and low voltage earthing electrodes shall be separated by a minimum of 4m.

HV surge arresters and the HV earthing system must not be connected to Air Break Switch Handles or down rods at separately earthed sites. The HV earth downlead must be kept well separated from the ABS handle and down rod.

For 33kV ABS with separate earthing, an earth mat is to be installed at the operator position, as shown in Figure 14.

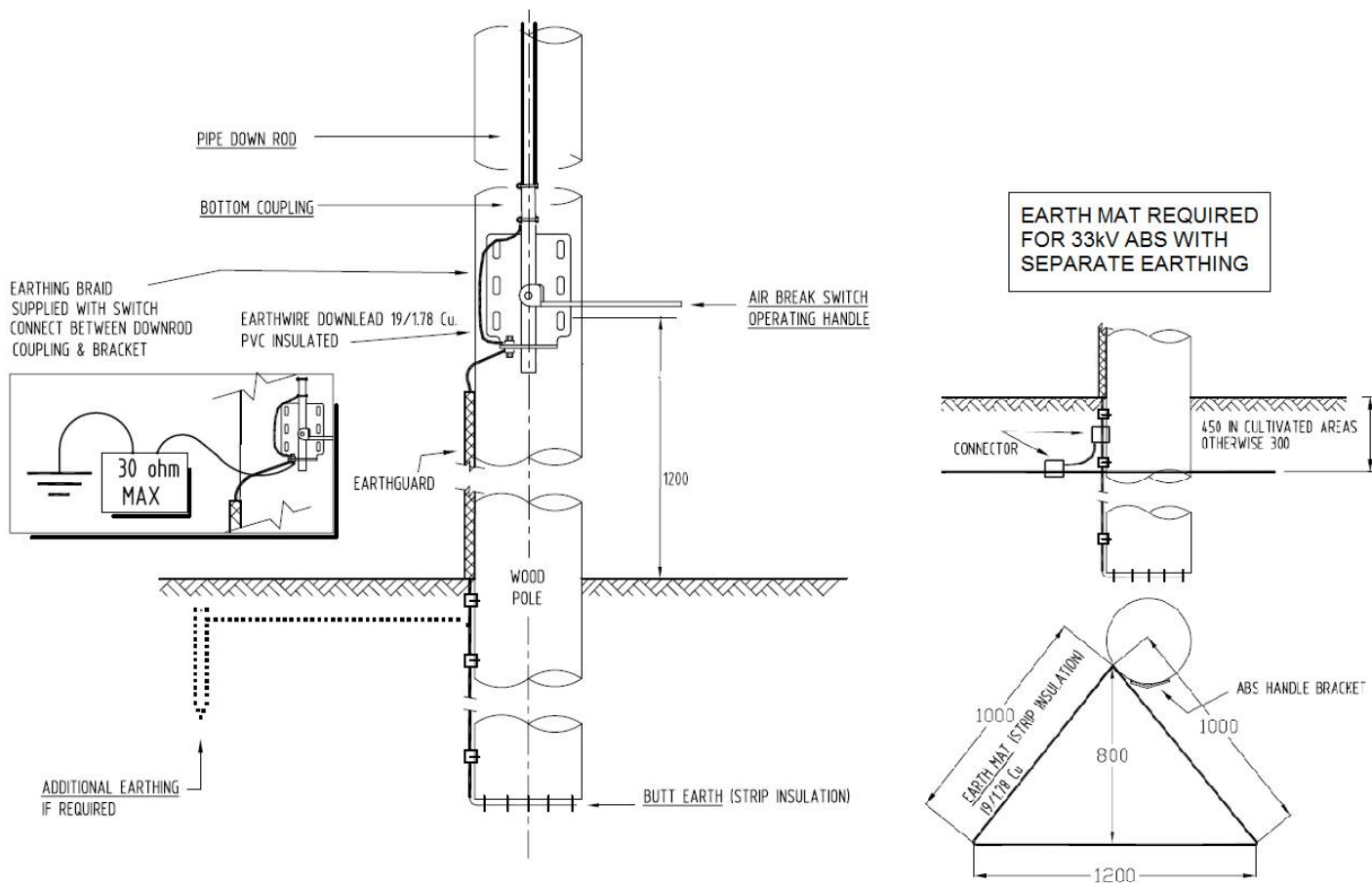

Figure 14: Air Break Switch Handle with Separate Earthing

8.8.5 Stay Wires

Stay wires coming within 2.4m of ground shall have an in-line insulator as per the Energex Overhead Construction Manual. The insulator shall be placed such that the base of the insulator is higher than 2.4m from ground and the end of the insulator is below the lowest conductor. The insulator shall also be located more than 1.5m horizontally from the pole Standards Australia Overhead line design (AS/NZS 7000, 2016).

8.8.6 All Other Metalwork within 2.4m from the Ground

All other metalwork below 2.4 m from ground not described above shall be bonded together with air break switch handles, metallic down rods and metallic cable guards and earthed to a resistance to ground not exceeding 30Ω. This will ensure that they all are at the same potential. Additionally, if a low voltage earth downlead exists on the pole, the metalwork shall be bonded to it.

8.9 HV Aerial Bundled Conductor

8.9.1 General

The catenary wire of HV ABC (i.e., aerial bundled cable) shall be connected to the high voltage earth with a local disconnected earth resistance of less than 30Ω, as it is capable of being energised by the high voltage conductors. The catenary shall be earthed at the following locations:

- Overhead/underground transition (i.e., surge arresters)

- At the ends of strain sections

The catenary shall be electrically continuous along the entire HV ABC run. It is to be earthed at regular intervals of no more than 300m.

The screens on the HV ABC conductors are not physically large so as to keep the overall weight down. Consequently, the screen current ratings are less than 2100A for an earth fault. The screens shall only have one earth at the source end only of each cable run. The screen is to be a maximum 300m in length before the screen is required to be separated. This is to prevent circulating currents and unsafe voltages on the screen. Refer to Figure 15 below and Energenx Overhead Construction Manual Section 4 for construction details.

Note: Screens for straight joints in-between the cable runs are to be joined continuously but not earth at the joint.

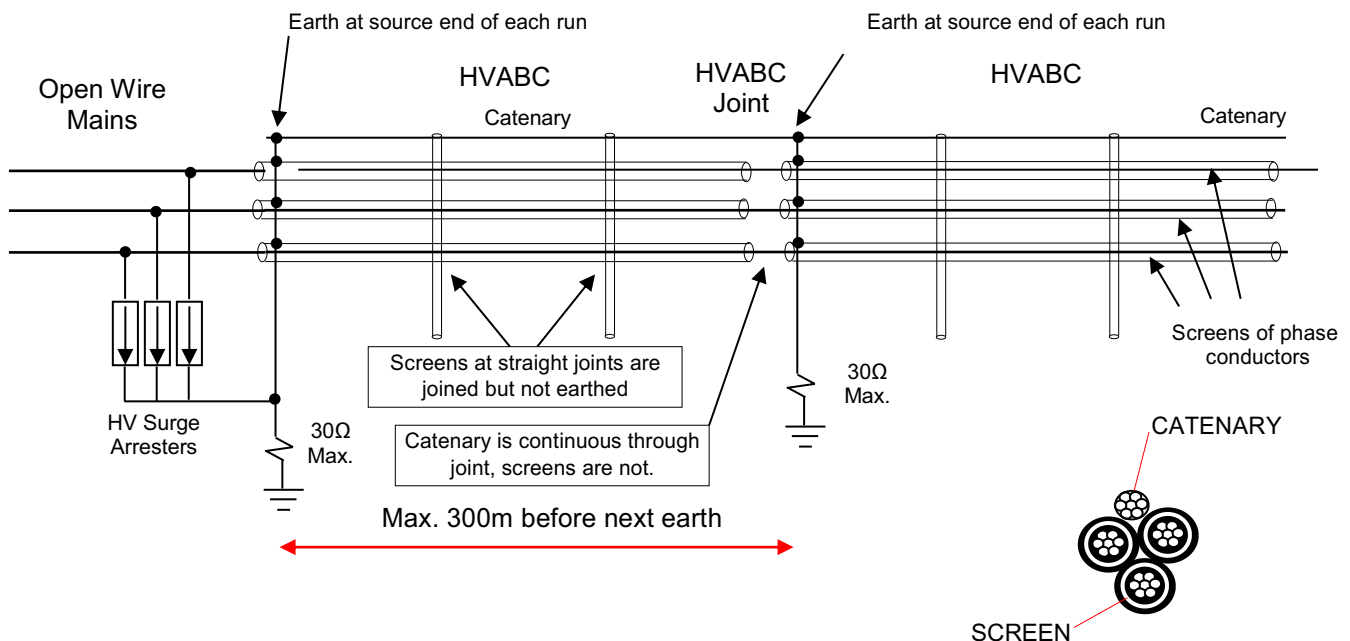

Figure 15: HV ABC Cable Earthing

*For HV ABC installed on conductive poles refer to section 8.4.3

8.9.2 CMEN System

The catenary wire and screens shall be connected to a local earth with a resistance to ground not exceeding 30Ω and bonded to the CMEN earthing system with an in-service resistance to earth at any point of less than 1Ω.

8.9.3 Separately Earthed High Voltage and Low Voltage (MEN) System

The catenary wire and screens must only be connected to the local high voltage earthing system with a resistance to ground not exceeding 30Ω. The high voltage and low voltage earth conductors shall be PVC insulated (or similar) with maximum separation on the pole and the high voltage and low voltage earthing electrodes shall be separated by a minimum of 4m.

8.10 High Voltage Covered Conductor

For high voltage 11kV CCT (i.e., Covered Conductor -Thick), surge arresters are installed one pole in from strain section ends and on every fourth pole, but not more than 250m apart. In high lightning areas, surge arresters are installed with closer separation. Note that surge arresters are only fitted to intermediate poles.

8.10.1 CMEN System

HV down leads shall be connected to a local earth with a resistance to ground not exceeding 30Ω and bonded to the CMEN earthing system with an in-service resistance to earth at any point of less than 1Ω .

8.10.2 Separately Earthed High Voltage and Low Voltage (MEN) System

HV down leads must only be connected to the local high voltage earthing system with a resistance to ground not exceeding 30Ω . The high voltage and low voltage earth conductors shall be PVC insulated (or similar) with maximum separation on the pole and the high voltage and low voltage earthing electrodes shall be separated by a minimum of 4m.

9 Underground Distribution Earthing Philosophy and Practice

9.1 Low Voltage Cable Pole Termination

The LV cable sheath, if present, shall be connected to the low voltage earth. The LV cable guard shall be installed as per Section 8.8.2.

9.2 High Voltage Cable Pole Termination

9.2.1 General

The HV 11kV cable sheath and surge arresters shall be connected to the high voltage earth. The HV cable guard shall be installed as per Section 8.8.3.

9.2.2 CMEN System

The HV cable sheath and surge arresters shall be bonded to the HV earth to form a CMEN earthing system with a connected resistance to ground not exceeding 30Ω and with a neutral to earth in-service resistance to earth at any point of less than 1Ω .

9.2.3 Separately Earthed High Voltage and Low Voltage (MEN) System

The HV cable sheath and surge arresters must only be connected to the local high voltage earthing system with a resistance to ground not exceeding 30Ω . The high voltage and low voltage earth conductors shall be PVC insulated (or similar) with maximum separation on the pole and the high voltage and low voltage earthing electrodes shall be separated by a minimum of 4m.

9.3 Cable Screen

Distribution cable screens or sheath should be earthed at both ends to provide a low impedance fault current return path and neutral point of the circuit, and to control the electric field stress in the cable insulation to prevent rapid degradation of the jacket caused by the capacitive charging current of the cable insulation, as well as provides shielding from electromagnetic fields. For transmission cable screens, consult Mains Design.

9.4 Padmount Distribution Substations

This category of earthing is for padmount substations with exposed metal work that can be touched by the general public. Sites may be fenced on three sides but open on the fourth side. This is typically used for up to 1000kV.A transformers. Apart from the transformer, the unit may include an RMU and LV switchboard.

Conductive railings or fences should not be bonded to the site earthing system as this will extend the EPR hazard to outside the fenced area. Customer's earth can only be connected to the substation earth where the substation incorporates CMEN earthing.

The CMEN system is the preferred method, however, should only be employed in areas where there is an abundance of low voltage interconnections and a low overall resistance to ground is achievable.

Some transformer sites have been designed with a common HV and LV earthing system but do not connect to any other transformer areas. (The earthing system would have complied with the QESI *Guide to Protective Earthing* and Energex's earthing requirements at the time of installation.) If such an installation requires upgrading, though, the designer shall be required to either:

- create an earth/neutral interconnection to other transformer areas and achieve the necessary conditions for CMEN earthing (this may be difficult if the site is in a remote location or there are obstructions preventing the installation of an interconnection), or
- reconfigure the installation to have separate HV and LV earths (this may be difficult if the substation is located on reinforced concrete that links to the consumer's installation, or if there is no suitable space around the site as a 'clearance zone'), or
- undertake a risk-based study according to the Standards Australia Overhead line design (AS/NZS 7000, 2016) or ENA Power System Earthing Guide (EG-0) Part 1: Management Principles (ENA DOC 025, 2022) and design earthing accordingly.

9.4.1 CMEN System

Where the CMEN system of earthing is used, the resistance between the connected LV neutral conductor and ground at any location is not to exceed 1Ω and individual disconnected local earths are not to exceed 10Ω .

The CMEN system of earthing shall have the following connected to it:

- transformer tank / metal equipment cabinet
- low voltage neutral
- any cable sheaths
- a local earthing system with a resistance to ground of no greater than 10Ω .

Where HV earth is not tied back via the LV neutral interconnections to the CMEN System

In special situations where HV plant (e.g., transformer, standalone RMU, HV metering unit) is required to be connected to the CMEN but has no LV neutral interconnections to connect back to the CMEN system. In such situations, the following methods can be used to make an earth connection / tie:

- Use the metallic screen of the HV cable (earth fault carrying capacity of $>6\text{kA}$ for 1 second), or

- Use a dedicated 70mm² copper cable as the earth tie for transformers up to 500kVA, or 120mm² copper for transformers up to 1500kVA.

Planners are advised to check the fault carrying capacity of the earth tie cable (or aerial neutral if overhead) to ensure the earth tie have an adequate fault carrying capacity back to the CMEN system. Refer to the Plant Rating Manual (4179110).

Labels as shown in Figure 16 should be attached to both ends of the earth tie. Refer to Standard for Network Labelling and Signage (3060382) for further details of required label.

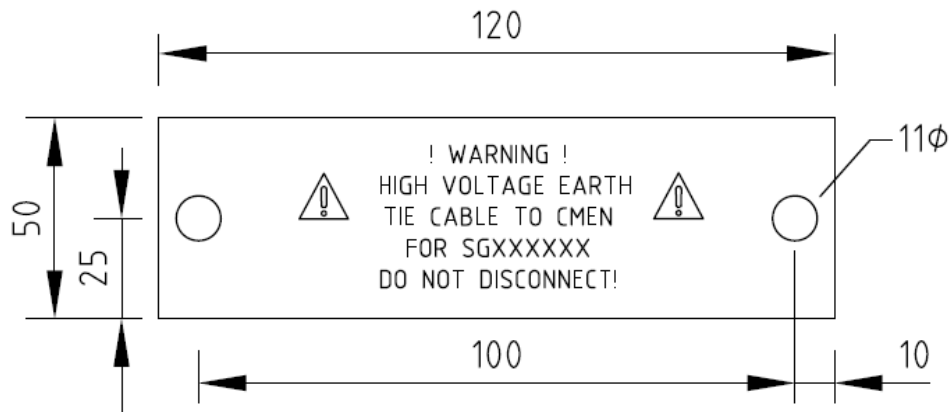

Figure 16: Label for HV Earth Tie to CMEN

Note: Labels to be made from 1.5mm ABS Plastic, or GRAVOPLY II, or similar, with black letters and yellow background.

9.4.2 Separately Earthed High Voltage and Low Voltage (MEN) System

The separately earthed system should only be used where the CMEN requirements cannot be met.

Two separate and distinct earthing systems shall be provided, as illustrated in Figure 17.

The high voltage earthing point is used for earthing all metalwork associated with the 11kV system including the transformer tank and metal enclosure. The disconnected resistance to remote earth of the separate high voltage earthing system shall not exceed 10Ω. The earth ring/grid around the padmount transformer is part of the high voltage earth system.

The low voltage earth is used for earthing the low voltage neutral. The disconnected resistance to remote earth of the individual low voltage earthing system at the transformer shall not exceed 10Ω. The overall resistance to ground of the interconnected low voltage neutral must not exceed 10Ω at any point. The low voltage earth conductors shall be PVC insulated (or similar). The high voltage and low voltage earthing electrodes shall be separated by a minimum of 5m.

The high voltage earth conductors, ground-mounted plant and associated concrete slab must have 5m separation from any consumer earth, other conductive structure, fence or building. This separation is to prevent a person or object from making contact between the HV earthed structure and any other conductive structure that may provide an earth return path, other than the HV earthing system. The separation must be comprised of non-conductive ground cover such as pavers, bitumen, or garden/green belt. Reinforced concrete is conductive and not an acceptable medium for ground cover. The separately earthed system requires a large ground area and separation from other conductive objects. Investigations need to be carried out in the planning/investigation stage to ensure appropriate location.

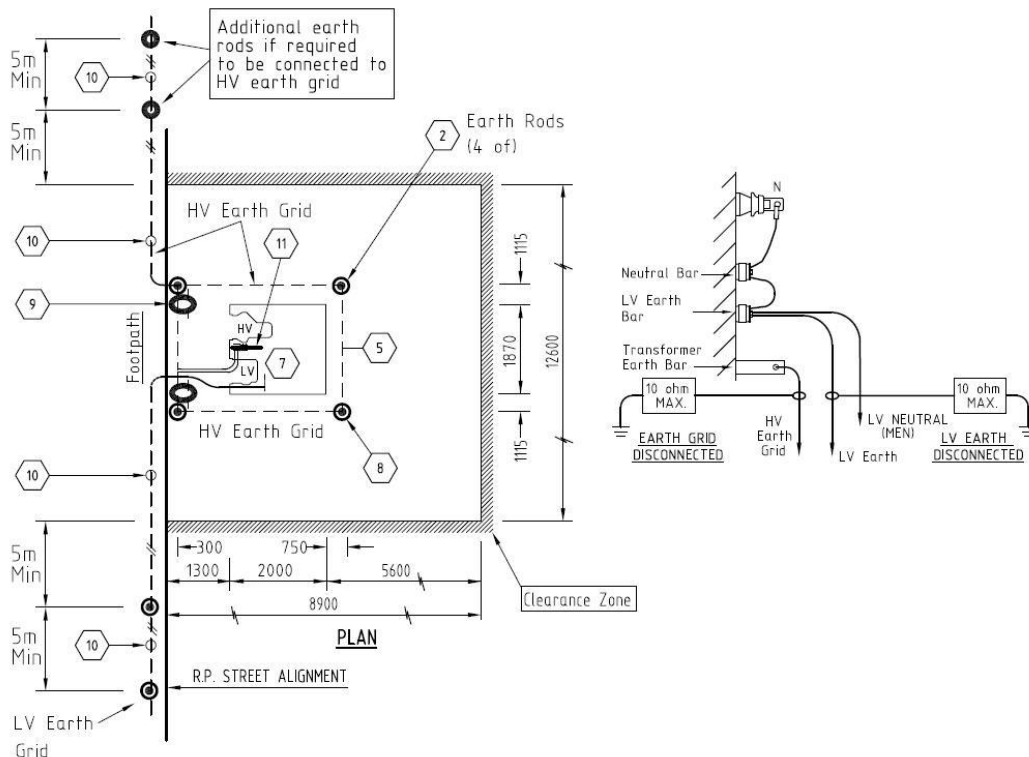

Figure 17: Padmount Transformer with Separate Earthing

9.5 Outdoor Ground Substations

9.5.1 General

This category of earthing is for ground substations where exposed metal work cannot be touched by the general public. Sites are fenced with concrete block walls. This is typically used for loads exceeding 1000kV.A and not able to be supplied by padmount transformers. Apart from transformers, the substation may include RMU's and LV switchboards.

Do not earth enclosure or gates as this will extend the EPR hazard zone, particularly when gates are open.

The CMEN system is the preferred method, however, should only be employed in areas where there is an abundance of low voltage interconnections and a low overall resistance to ground is achievable.

The earth ring around the perimeter of the site, just inside the walls, shall be connected to the HV earth.

9.5.2 CMEN System

Where the CMEN system of earthing is used, the resistance between the connected LV neutral conductor and ground at any location is not to exceed 1Ω and individual disconnected local earths are not to exceed 10Ω. In cases where the neutral does not have a low enough resistance to ground, interconnection to other areas using lead sheath of HV cable or 70mm² copper cable earthed at 100m intervals is advisable. For earthing at 100m intervals, each individual earth shall be 30Ω maximum.

The CMEN system of earthing shall have the following connected to it:

- transformer tank
- RMU tank/enclosure
- LV switchboard enclosure
- low voltage neutral
- any metal work such as cable sheaths; and
- a local earthing system with a resistance to ground of no greater than 10Ω.

9.5.3 Separately Earthed High Voltage and Low Voltage (MEN) System

The separately earthed system should only be used where the CMEN requirements cannot be met.

Two separate and distinct earthing systems shall be provided.

The high voltage earthing point is used for earthing all metalwork associated with the 11kV system including the transformer tank as well as all equipment cabinets, also the metal enclosure around the LV switchboard³, so that persons within the substation cannot make contact with two items of equipment at different potential. The disconnected resistance to remote earth of the separate high voltage earthing system shall not exceed 10Ω.

The low voltage earth is used for earthing the low voltage neutral. The disconnected resistance to remote earth of the individual low voltage earthing system at the transformer shall not exceed 10Ω. The overall resistance to ground of the interconnected low voltage neutral must not exceed 10Ω at any point.

As with a padmount transformer site, the high voltage earth conductors and ground-mounted plants must have 5m separation from any consumer earths, other conductive structures (apart from the substation enclosures), fences, buildings or LV earths. The separately earthed system requires a large ground area and separation from other conductive objects. Investigations need to be carried out in the planning/investigation stage to ensure appropriate location.

9.6 Free-Standing 11kV Equipment

9.6.1 General

This section is for free-standing 11kV equipment such as RMUs (ring main units) and ground-mounted switches with no LV components but with exposed metal work that can be touched by the general public, e.g., where located on or adjacent to the footpath or in a park. All 11kV equipment shall be connected to the local 11kV earth, as the equipment is capable of being energised by the 11kV conductors in the event of a fault.

Conductive railings or fences should not be bonded to the site earthing system as this will extend the EPR hazard to outside the fenced area. Customer's earth can only be connected to the substation earth where the substation incorporates CMEN earthing.

The CMEN system is the preferred method, however, should only be employed in areas where there is an abundance of low voltage interconnections and a low overall resistance to ground is achievable.

³ The LV neutral shall be insulated from the frame/cubicle of the LV switchboard.

The earth ring around the perimeter of the plant item shall be connected to the HV earth.

9.6.2 CMEN System

11kV plant earths shall be bonded to the CMEN earthing system with a disconnected resistance to ground not exceeding 10Ω and with an in-service connected resistance to earth at any point of less than 1Ω . As there is no local LV earth associated with the item, interconnection to other areas using the sheath of HV cables (if rated greater than 6kA for 1 second) or 70mm^2 copper cable earthed at 100m intervals is required. For earthing at 100m intervals, each individual earth shall be 30Ω maximum.

At the site, the CMEN system of earthing shall have the following connected to it:

- equipment tank / metal enclosure
- any metal work such as cable sheaths; and
- a local earthing system with a resistance to ground of no greater than 10Ω .

For situations where free-standing 11kV equipment is required to be connected to the CMEN, and there are no LV neutral interconnections to connect back to the CMEN system, refer to Section 9.4.1.

9.6.3 Separately Earthed High Voltage and Low Voltage (MEN) System

The separately earthed system should only be used where the CMEN requirements cannot be met.

At the site, the system of earthing shall have the following connected to it:

- equipment tank / metal enclosure
- any metal work such as cable sheaths, and
- a local earthing system with a resistance to ground of no greater than 10Ω .

The high voltage earth conductors, ground-mounted plant and any associated concrete slab must have 5m separation from any consumer earth, other conductive structure, fence, building or LV earth. This separation is to prevent a person or object from making contact between the HV earthed structure and any other conductive structure that may provide an earth return path, other than the HV earthing system. The separation must be comprised of non-conductive ground cover such as pavers, bitumen, or garden/green belt. Reinforced concrete is conductive and not an acceptable medium for ground cover.

Note: The separately earthed system requires a large ground area and separation from other conductive objects. The high voltage earth conductors, RMU and associated concrete slab must have 5m separation from any other conductive structures, fences, buildings, or LV earths. Investigations need to be carried out in the planning/investigation stage to ensure appropriate location. It is often not possible to use a separately earthed system for footpaths as it requires too large an area.

9.7 Indoor Distribution Substations

The CMEN system of earthing shall be used for indoor distribution substations. Separate earthing is not practical even in rural areas as Energex's HV equipment is on the same concrete slab as the customer's LV equipment. The resistance between the LV neutral conductor and ground at any location is not to exceed 1Ω and individual local earths are not to exceed 10Ω . A minimum of three distribution transformer neutral circuits (approximately 100 earth rods) shall be interconnected. Interconnection to other areas may be by LV neutral, lead sheath of HV cable or 70mm^2 copper cable earthed at 100m intervals. For earthing at 100m intervals, each individual earth shall be 30Ω maximum.

At the indoor distribution substation, the general earthing guideline is as follows:

1. Bond all exposed metal work to earth inside the substation:
 - if it can be energised when a fault occurs, or,
 - if it is touchable at ground level and not isolated – if a metalwork is too high up for a person to touch ($>2.4\text{m}$) and is not galvanically bonded to areas below, it does not need to be earthed as there is a low probability for access. e.g., isolated metal works up near high ceiling.
2. Avoid extending EPR hazard zone out towards the boundary / public access area (i.e., avoid transfer potential issues to outside the substation room). e.g., conductive louvers should not be earthed when earth grid cannot be extended outside to cover the area 1m outside the substation (to cater for public leaning against louvers when fault occurs).

The CMEN system of earthing shall have the following connected to it:

- transformer tank
- all equipment cabinets/frames
- low voltage neutral
- any metal work such as cable sheath
- a local earthing system with a resistance to ground of no greater than 10Ω .

If the substation is not on the level directly above ground, then two 120mm^2 copper insulated riser cables shall be provided on separate routes from the basement/ground floor earth grid to the remote substation enclosure. The earth grid is to be located directly under the substation footprint where practicable, even when substations are located on upper levels of buildings. It is desirable that there is one common earthing system with the substation earth connected to the customer switchboard neutral, lightning protection system and communications earth.

The substation layout should ensure that there is sufficient clearance (at least 2m) between equipment earthed to the substation earth mat and any other conductive objects with another earth connection such as telephones and associated cables. This clearance is not required to floating metal work that is not electrically connected to another earth or the reinforcing in concrete, e.g., cable trays. Pilot isolation cubicles are made of timber and have a rubber floor mat to ensure 15kV insulation to the pilots which may be at a different potential to the substation earth mat. Air conditioning ducts are often located close to transformers for extra cooling. Note that metallic air conditioning ducts are connected to a remote power source that may be at a different potential to the substation earth mat. Therefore, the duct should be either bonded to the substation earth ring and the consumer's MEN, or else insulation applied to minimise the risk of a person contacting both simultaneously.

Note: Commercial and Industrial substations with relay operated switchgear can have different earthing requirements. Refer to Energex Commercial and Industrial Substation Manual (3060052) and consult the substation design department for details.

10 Streetlight

10.1 Streetlight Columns

10.1.1 Rate 1 and Rate 2 Lighting Arrangements

All metal and concrete poles shall employ MEN earthing by direct connection to the supply neutral. The copper earthing conductor shall have a cross sectional area of not less than 6mm². The MEN point is created by bonding the neutral conductor to the pole.

For extended overhead streetlight circuits, MEN electrodes are to be installed as per the Energex Overhead Construction Manual for LV circuits.

Streetlight columns are normally self-earthing through their base, with the neutral bonded to earth at each location. This obviates the need to run an earth wire along with the active and neutral conductors.

For SBM poles, a 6mm² copper earthing conductor is required to be run from the junction box in the supply pit (where it is bonded to the neutral terminal) to the earth connection point on the streetlight footing. An earth lead is not necessary for BPM poles between the junction box and the earth connection point as there is a lead between the neutral terminal and the earth connection point at the terminal panel in the pole.

For streetlights attached to wood poles, no earth connection is to be made. Where streetlights are constructed on conductive distribution poles (e.g., concrete and steel poles) the brackets are to be bonded to the pole. For concrete poles this shall be by an earth strap from the bracket to an earth ferrule.

The Queensland Public Lighting Construction Manual provides further details of the earth connections for each street light arrangement.

10.1.2 Non-Metered (Rate 3) Public Lighting

All rate 3 lighting arrangements must comply with the requirements of Standards Australia Electrical installation (Wiring Rules) Standards Australia Electrical installation (Wiring Rules) (AS/NZS 3000, 2018). The Public Body must install a switchboard containing a main switch, circuit protection, neutral link, and MEN connection. The consumer's street light supply cable must contain an earth wire that is connected to each streetlight in the circuit.

Poles that incorporate a rag bolt foundation do not require a separate earth electrode as the foundation provides a sufficient means of earthing. However, the earth conductor must be attached to the earth connection point on the streetlight footing.

10.1.4 Remote Areas and Bridges

In situations where pole foundation cannot provide an effective earth (bridges, overpasses, underpasses with bulkhead lighting or remote areas), or there is no MEN system available, a separate earthing system should be employed. The earth conductor shall be installed with the supply cabling and shall have a cross-section area according to the requirements of the Standards Australia Electrical installation (Wiring Rules) (AS/NZS 3000, 2018), but in any case, shall not be less than 6mm² (copper). The earth cable shall be connected to an “effective earth point” (or nearest available MEN) at the first appropriate pit, pillar, or pole clear of the (bridge) structure. At each streetlight pole on the (bridge) structure, the earth cable shall be bonded to the pole, but not the neutral.

10.1.5 Joint Use Poles – Isolation

Where joint use steel poles are installed for traffic management (mainly traffic lights) and road lighting, there will be separate LV supplies and LV panels within the poles. To ensure that the road lighting supply may be located and isolated in the event of an emergency and in the course of maintenance work on the traffic light system it is required that the road lighting shall be supplied from a service pit containing a junction box kit including a 20 A fuse-switch combination, installed where practicable within 1m of the joint use pole/column.

10.1.6 Lighting Columns on Foreshores or near Water Parks

Conductive lighting columns at locations near a public swimming pool area, popular beach or water recreation area may require an earthing risk assessment (Refer Section 5.5 regarding *special locations*).

11 Telstra and Optus Plants

Optus assets are to be treated the same as Telstra equipment and follows the same principle guidelines with regards to earthing coordination.

11.1 Telstra / Energex Power Coordination Guidelines

Arrangements for the coordinated installation of Energex and Telstra assets are detailed in the Energex Telstra Power Coordination Guidelines. The information is repeated here to keep the earthing policy centrally documented in this Standard.

These arrangements have been prepared and are necessary to ensure that earth potential rise from Energex high voltage earthing systems under fault conditions do not create hazards for Telstra personnel. This is achieved by ensuring appropriate separations between Telstra plant and HV distribution plant earthing systems.

The latest edition of Energex Telstra Power Coordination Guidelines has been updated from the previous to provide updated contact details for notification/enquiries for Telstra and Energex, and in addition, lists further explanatory information including:

- Notes on the Table of Minimum Separations (Appendix A) are enhanced,
- A procedure for installing and signposting remote earths when clearances become difficult to achieve
- Metallic sheath explanatory material added
- LFI explanatory material added

- Telstra above ground equipment housing detail added
- Telstra standard forms for pole maintenance/changeover added

The Energex Telstra Power Coordination Guidelines includes the following guidelines:

- Consideration of EPR – Table of Minimum Separations between Telstra Plant and HV Distribution Plant Earthing Systems (Refer to Appendix A).
- Consideration of LFI – Flowchart indicating maximum parallel exposure before LFI is likely to exceed acceptable limits (Refer to Appendix C).

Notes:

- Designers should use the “Distribution Transformer” or Air Break switch” categories when considering other HV plant not mentioned specifically in the following table.
- Responsibilities and contacts for both Energex and Telstra are contained in the Guidelines

11.2 Remote HV Earth

Sometimes the location of HV plant likely to cause EPR is within the allowable separation distances from Telstra plant. An EPR mitigation technique using a remote (or Off-site) HV Earthing System can be used relocate the HV earth system via an insulated earth conductor away from the Telstra plant.

Poles with HV earth in close proximity Telstra plants that exceeds the minimum clearance (Refer to Appendix A) and cannot be relocated should have remote earths installed (Figure 18) as per the Energex-Telstra Coordination agreement guidelines.

This solution meets the requirements for the EPR Code separations but unless the mitigation is known to others, (Telstra), then this technique creates more problems than it solves. Over time Telstra will place plant away from the HV site unaware that a remote HV earth system is nearby.

In some cases, remote HV earthing systems have been used where one was not required. For example, a pole mounted transformer 5m from a Telstra cable pit with cable joints. The planner has been under the assumption that a 15m separation was always required when in fact in a CMEN area with common HV-LV earths and an extensive MEN earthing system a 2m separation would be acceptable.

In general, to use a Remote HV Earthing System one should:

1. Indicate the presence of a Remote HV Earthing System by placing a sign on the pole with the wording:
 - “WARNING – Remote HV Earth due to Telstra Plant within 15m” (non-CMEN area), or
 - “WARNING – Remote HV Earth due to Telstra Plant within 2m” (CMEN area).
2. Indicate the direction that the Remote HV Earthing system is installed by placing the sign on the side of the pole pointing to the earth system
3. Indicate the distance to the Remote HV Earthing System by placing a Type 2 pit at the intersection of the insulated earth cable and the location of the 1st electrode. The electrode should have a marker tag attached with the wording “WARNING - Remote High Voltage Earth – DO NOT REMOVE”.

Standard for Distribution Earthing

Presence of a remote HV earthing system should be indicated by placing the following signs:

Pole label:

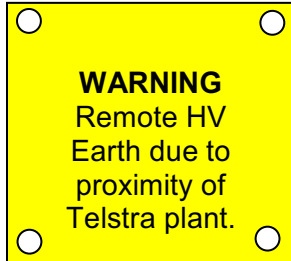

Material: 1.6mm thick anodised aluminium plate
 Lettering: Black lettering on yellow background
 Size: 200mm x 150mm.
 Standard for Network Labelling and Signage (3060382)
 Drawing: 9153-A4.
 Stock code: 20782.

Marker tag:



Material: ABS plastic (1.5mm) or similar
 Lettering: Black lettering on yellow background
 Size: 80mm x 45mm
 Standard for Network Labelling and Signage (3060382)
 Drawing: 9154-A4
 Stock code: 20783. **CU: HVEREMOTE**

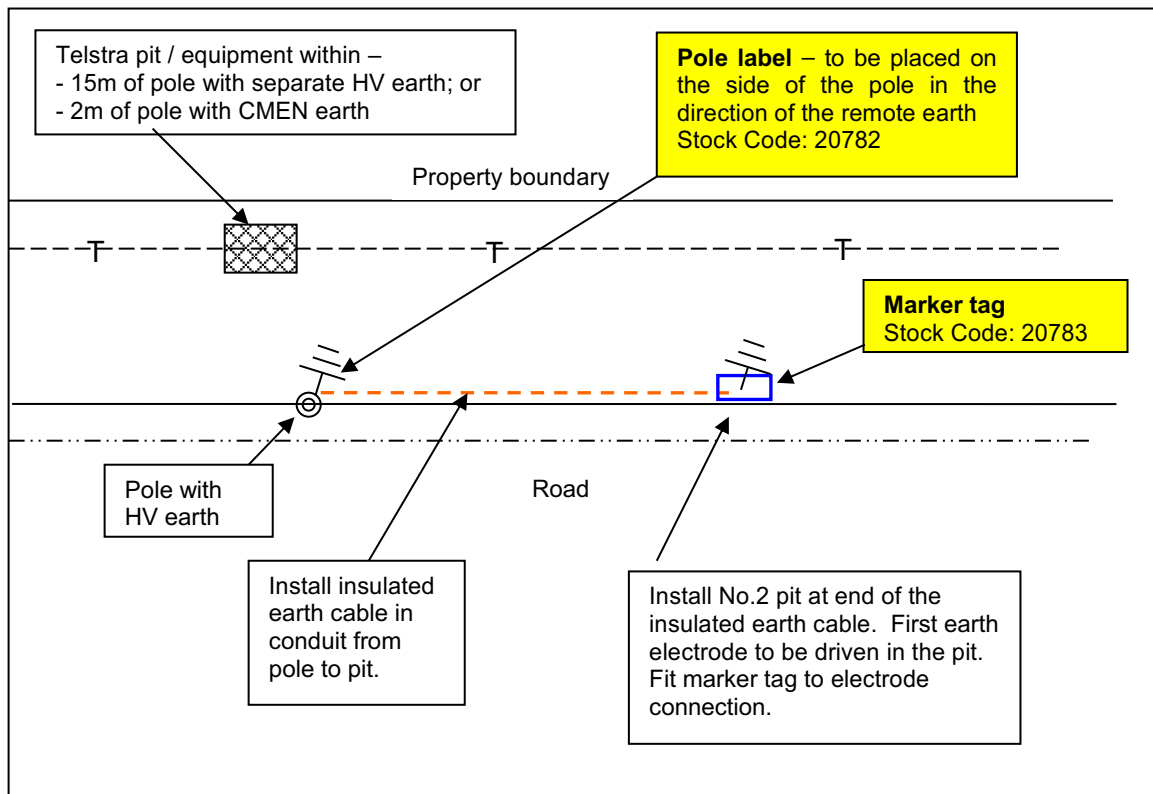

Figure 18: General Arrangements for Remote HV Earth and Telstra Plants

11.3 Street Mounted Telecommunication Equipment

Various types of Telstra street-mounted telecommunications equipment are shown below. All of the equipment shown below can be very expensive to remove if affected by EPR from a HV earthing system.

<p>Cable pillar and associated cable pits</p> 	<p>RIM Series 1</p> 
<p>RIM Series 2</p> 	<p>RIM Series 3</p> 
<p>CMUX (Left) and Rim Series 1 (Right)</p> 	<p>Cable Pillar and RIM</p> 

11.4 Telstra Metallic Sheathed Cable Types

Telstra cable plans obtained from Dial-Before-You-Dig (1100) show the location and type of Telstra's telecommunications plant. Cable installed into the network today has a polyethylene or plastic insulating jacket or sheath. Telecommunications cables can have a very long service life of 30 to 40 years and metallic sheathed telecommunications cables were once used extensively throughout the telecommunication network and many remain in the network.

A four, five, or sometimes six letter code identifies conductor insulation and physical arrangement – see diagram below. Older paper insulated conductor types point towards a metallic sheathed cable.

Only if the cable type starts with the letter PI (Paper Insulated) should one suspect the cable type is metallic sheath.

_____	PIxx	_____
_____	PIxxx	_____
_____	PIxxxx	_____

However, many later issue PIxxxx cables used polyethylene or plastic jackets, and these would not be considered to have a metallic sheath. These are identified by the letters PE, MB, MBHJ or HJ sometimes as the two letters of the cable type or as separate letters marked just above, or on, the cable.

_____	PIxx	_____ PE
_____	PIxxx	_____ MB
_____	PIxxxx	_____ MBHJ
_____	PIxx	_____ HJ

While the separations listed in column 2 of the Appendix A above do not apply for insulated Telstra cable sheaths a minimum separation of 300mm between insulated Telstra cable sheaths and HV earthing systems is still required as part of the joint codes, *EPR Code of Practice* and the *Recommended Practices For Plant Underground*.

12 Queensland Rail Traction Earth

12.1 General Guidelines

In general, interconnection between the two earthing system is **not** permitted. The reason for this is that Queensland Rail (QR) HV system operates at 25kV AC. Under earth fault conditions, up to 5kA of phase to earth fault current can flow to earth. QR has indicated their protection operation time is generally under 0.4 seconds. While the majority fault current is likely to flow back via QR's own traction earth system under fault conditions, however, if the two earthing systems (QR & Energex) are interconnected, there may be significant fault current flowing into Energex's CMEN system. As Energex equipment is not designed to handle fault currents from QR, damage to Energex plant may occur. Furthermore, the risk is exported to the general public from fault current flowing into the MEN system.

Energex's MEN system must be isolated from QR HV track rail earthing system with the use of a suitable isolation transformer. Queensland Rail is responsible for ensuring that such interconnection is not made (either directly, or indirectly, e.g., electrical bonds, fences, water pipes or metal works, etc.). A minimum of **5m physical separation** is required between the two earthing system. This includes both above ground metallic structures, as well as below ground conductive structure.

12.2 Non-Standard Arrangement

In special situation where two earthing systems cannot be separated, such as existing QR sites in the city district, QR and its associate contractors must consult Energex to reach a solution on a site-by-site basis. In general, for this type of situation, the distribution transformer must be a dedicate feed to the local QR station and cannot feed out to any other customers. HV Cable screens may need to be disconnected at the distribution transformer end to prevent QR traction fault from being imported into Energex's CMEN system.

13 Customer Installation Earthing

13.1 General

As the MEN system relies on the interconnection of customers earthing as well as utilities earthing system to form a low impedance MEN system, customer cannot rely completely on distribution utilities for the local earthing system of their premises. The provision of local earthing facilities for customers' installations is the legal responsibility of the customers themselves. This applies to both high voltage and low voltage supplies. High voltage customers shall provide their own earthing arrangements for the low voltage systems on their own premises.

13.2 Non-Standard Arrangement

In certain situations, customers may, at the discretion of Energex, request to have their main switchboard connected directly back to the Energex Substation earth via a main earthing conductor. This may be acceptable where it is impossible for customers to achieve effective earthing by other means and where the two earthing systems cannot be effectively isolated. E.g., in a Chamber substation where the substation earth is in the basement of a high rise building, and the customer switchboard shares the same reinforced concrete slab as the substation.

The earthing conductor is to be chosen according to the requirements in Section 5 of Standards Australia Electrical installation (Wiring Rules) (AS/NZS 3000, 2018) and tagged at both ends with "Consumer Earth" Tags (SC6424), with the MEN link made at the substation as per *Figure 5.2 - MEN System of Earthing – Alternative Arrangement* of Standards Australia Electrical installation (Wiring Rules) (AS/NZS 3000, 2018).

Where approved, the Customers Main Earthing conductor must be:

- Sized in accordance with Standards Australia Electrical installation (Wiring Rules) (AS/NZS 3000, 2018) and
- Tagged where it connects to the Energex earthing system and at the customers main switch board with "Consumer Earth" Tags (SC6424)

Permission shall be granted on a case-by-case basis and the contractor must apply early to their local hub contacts to ensure the connection can be made in a safe and economical manner.

14 Mitigation Measures

14.1 General

This section describes the various common mitigation methods to control the step and touch potentials aside from reducing the impedance to earth.

As described previously, the control method revolves around two central concepts:

- Bonding of conductive parts to an effective (low impedance) earthing system, or
- Physical separation (Isolation).

14.2 Grading Ring

One method to reduce touch potentials is to install a grading ring (as shown in Figure 19). The concept is to install a conductor under the ground beneath where people stand and connect this conductor to the earth electrode. This has the effect of reducing the voltage gradient near the earth electrode. Note the hump in the voltage versus distance curve. The step potential may be increased with a grading ring but compared to a touch potential, this is of lower consequence (particularly if the person is wearing shoes). A grading ring will reduce the touch potential to between 25% and 75% of the value without a grading ring depending on soil conditions. For conservative design, assume the touch potential with a grading ring is 75% of the value without a grading ring.

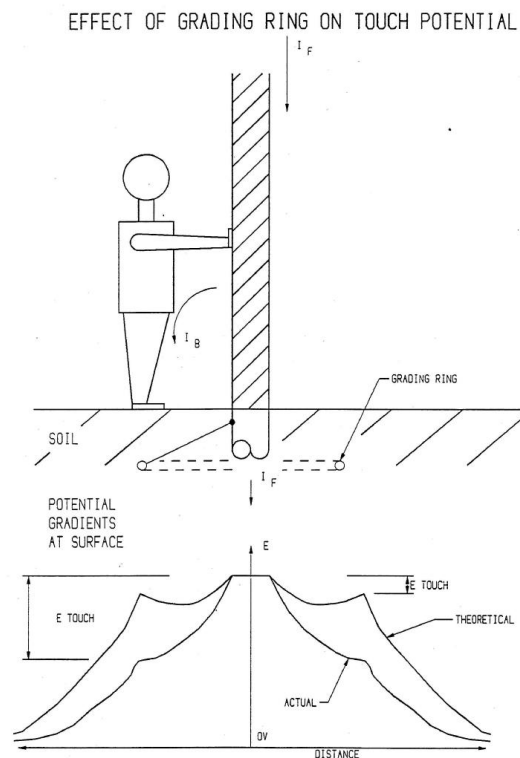

Figure 19: Grading Ring Reduction of Touch Potential

14.3 Reducing Resistance of Return Path

The CMEN and MEN systems of earthing take advantage of multiple earth electrodes to lower resistance of the neutral and EPR on the neutral. Where required, these systems can be enhanced to reduce the resistance of metallic return paths back to the source substation. This can be achieved by fitting either an overhead or underslung earthwire for overhead networks, which is then earthed at both ends. For underground networks, a larger screen and/or an additional return conductor with screen and return conductor bonded to earth at both ends can be installed in the trench.

14.4 Deep Earth with Upper Level Insulation

Another method to control step and touch potentials is to insulate the top section of a deep drilled earth to inject the current lower down into the soil. This method may actually increase touch potentials. However, it is particularly useful for reducing EPR in the vicinity of telecommunications cables.

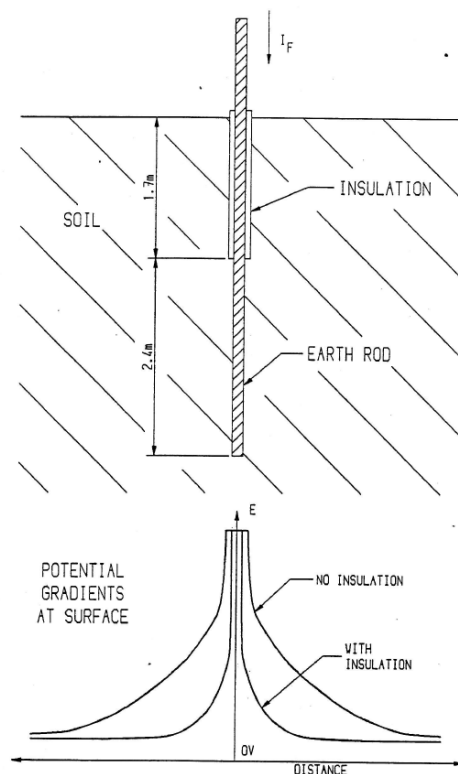

Figure 20: Deep Earth Electrode with Insulated Top Section

14.5 Insulation Layer

Another method to reduce touch and step potentials is to apply a high resistivity surface layer on the ground around the electrode. Materials such as rocks and bitumen may be used. A surface layer of rocks is often used in substations. Insulating the base of the pole is another method. An important consideration with these methods is the ongoing cost of maintenance to ensure integrity of the insulating layer over the life of the electrical asset.

14.6 Non-Conductive Fence

In areas where it may not be possible to reduce EPR or earthing impedance, a common method of mitigate the touch potential risk is to install a non-conductive fence around the ground substation / HV equipment. Non-conductive panels can also be used to prevent transfer of potentials at the boundary of padmount sites where neighbours may install metallic fences outside Energex's control.

14.7 Double Insulation (or Reinforced Insulation)

Under Standards Australia Electrical installation (Wiring Rules) (AS/NZS 3000, 2018), exposed conductive parts of electrical equipment shall be earthed, unless they are protected by the use of double insulation. If for any reason one insulated layer is pierced, there is layer acting as a redundancy measure to help ensure the equipment using this method is continuously insulated and thereby mitigating the risk of any hazardous touch potential.

Reinforced insulation is a single insulation system that provides a degree of protection equivalent to double insulation under conditions specified in Standards Australia Approval and test specification — General requirements for electrical equipment (AS/NZS 3100, 2022) (e.g., Aerial Bundled Cables in accordance with Standards Australia Cross-linked polyethylene insulated - Aerial bundled - For working voltages up to and including 0.6/1(1.2) kV (AS/NZS 3560) are deemed to provide reinforced insulation.)

14.8 Separation of Structures and Earths from 110/132kV Transmission Structures

Earth faults on 110/132kV overhead transmission circuits can cause high earth potential rise in the vicinity of the towers or poles. The earth fault current flows in the overhead earthing system to adjacent structures and the current flowing down each of the structures produces a transient earth potential rise which will drop off as a function of:

- Distance from tower/pole
- Soil resistivity
- Return current that flows in overhead earth wire
- Number of spans away from faulted tower/pole

A metallic fence with steel post supports can increase potentials in the ground by moving the remote earth point closer to the conductive structures.

It is recommended that the following are **not** installed within a 20m radius of any 110/132kV transmission tower or pole:

- Padmount transformer sites and associated earth grid/earth rods.
- Ground and pole mounted transformers and associated earthing system
- MEN earth rod in LV pillars or on poles.
- Conductive poles and streetlight columns.
- Customer - Swimming pools, conductive structures (garden sheds, steel property poles, metallic fences etc).

If these clearances cannot be maintained, the designer shall conduct a risk based earthing study in accordance with ENA Power System Earthing Guide (EG-0) Part 1: Management Principles (ENA DOC 025, 2022) to ascertain that the design meets the requirements of a low or tolerable risk in accordance with this guide.

The high earth fault currents on the transmission lines can also cause electromagnetic induction (voltage and currents) in adjacent metallic fences and pipelines. Special measures (such as isolating sections and the installation of additional earthing) may be required to mitigate the induced voltages. Based on current earth fault currents, these measures are usually required if the parallel exposure of the fence or pipeline is more than 400 metres.

Items exempt from this 20m exclusion zone include:

- Buried insulated electric cables (0.6/1kV insulated and above)
- Underground service pillars (without MEN)
- Plastic streetlight service pits

Other non-conductive structures

Appendix A

Informative

Revision History

Version	Date	Description
7	12/07/2023	<ul style="list-style-type: none"> Modified: <ul style="list-style-type: none"> Document name changed from Energex Distribution Earthing Manual (RED00758) to Energex Standard for Distribution Earthing Document updated onto new template Updated numbers in Figure 5 to match construction manuals Updated references as required
6	10/08/2017	<ul style="list-style-type: none"> Revised with no material changes
5	21/06/2017	<ul style="list-style-type: none"> Modified: <ul style="list-style-type: none"> Foreword Added Section 12.8 works around 110/132kV towers Added Appendix 2 – Probabilistic Design to AS2067
4	14/08/2015	<ul style="list-style-type: none"> Modified: <ul style="list-style-type: none"> Section 6.8.2 – Earth on LV cable guard not required if installed in conduit Section 9.2 – change pit type from No.4 to No.2 to make consistent with OCDM Appendix 1 – Added clearances for DT on conductive poles – consistent with OCDM (was missing on last release)
3	03/03/2014	<p>Added:</p> <ul style="list-style-type: none"> Cover Page – added diagram to show other Energex manual and documents related to distribution earthing. Added Disclaimer. 4.1 Design Objective added, partly taken from old Section 2. Section 8 – Streetlight – made consistent with the Public Lighting Design Manual. Section 9 – Telstra & Optus Plants – consistent with ODM Sec9 Section 10 – Queensland Rail Traction Earth. Section 11 – Customer Installation Earthing – partly taken from FAQ. Section 12 – Mitigation measures. Appendix 1 - Consideration of EPR (Telstra separation table). Appendix 2 – Consideration of LFI (Telstra). <p>Modified:</p> <ul style="list-style-type: none"> Amendment Records moved to front of the document. 1.5 – Updated department and document names. 3.4 – Notes added 5.2 – Added explanation on the basis of CMEN requirement (AS2067) 5.3 – Minor clarification on transformer neutral which requires 10ohms. 6.1.1 - Telstra plants with remote earth have been moved to 9.2. 6.1.3 – SWER - Figure 8 - revised with correct minimum clearances.

Standard for Distribution Earthing



Version	Date	Description
		<ul style="list-style-type: none"> • 6.4.2 – Revised to comply with current practices. • 6.4.3 – Added type of pole (conductive) • 6.9.1 – Fixed inconsistencies on HVABC to be consistent with OCHM. • 6.10 – Deleted unused /unknown definitions CLAH. • 7.3 – Rename cable “sheath“ to “screen”. Revised section with more details. • 7.7 – Indoor Distribution Substations - revised with general guideline & added notes on relay operated switchgears. • Old 7.8 – Public lightning - moved to section 8. • Revised 8.1.3 (old 7.8.1) on street light column earthing over bridge. • Appendix 3 –Summary of earthing requirements – re-numbered from Appendix 1 & revised to keep consistent with ODM
2	11/01/2014	Updated to major version to suit new document management system. No change to content
1.4	30/06/2013	Section 6.11 added for Telstra plants with remote earth.
1.3	12/04/2013	Revised minor error in section 7.4.1 – change responsibility from designer to planner as per Standard Alert 259.
1.2	01/12/2012	Revised Section 7.4 and 7.6.2 to clarify CMEN tie to HV ground mounted plant in situations where there are no LV neutral interconnections.
1.1	31/10/2012	Updated Section 3.4 with 1440mm earth rods. Fixed typo on page 1.
1.0	20/09/2010	<p>Initial Issue—Material excised from ‘Supply and Planning Manual’ into stand-alone document.</p> <p>Added material on underground networks, CCT and HVABC.</p> <p>Upgraded material on streetlights.</p> <p>Added diagrams and section on earthing locations. Expanded section on earthing electrodes.</p> <p>Increased earth lead size for indoor substations with remote earths to 120mm².</p> <p>Expanded on <i>special locations</i> and situations where a risk assessment in accordance with <i>AS/NZS 7000 / EGO</i> is required.</p> <p>Amended requirements for upgrading CMEN existing substations without neutral/earth tie to other substations.</p> <p>Added appendices summarising earthing installation target values and telecommunications clearances.</p>

Appendix B

Normative

Consideration of EPR – Table of Minimum Separations between Telstra Plant and HV Distribution Plant Earthing Systems

	TELECOMMUNICATIONS PLANT TYPES Includes: Pillars, Cabinets, Cable Pits, Manholes, Non-insulated Metal Sheathed Telstra Cables ⁵ , Telstra Earths, Lightning Guard Wires, Payphones, Customer Equipment	TELEPHONE EXCHANGES Includes: Radio Sites, Street Mounted Equipment Housings ⁸ (similar to but larger than a traffic signal box. See pictures over page)
CONDUCTIVE POLES SUPPORTING HV LINES: Without OHEW or pole commoned to MEN With pole bonded to OHEW With pole bonded to MEN	15 metres 5 metres ^{1,2} 2 metres ^{1,2}	15 metres 5 metres ^{1,2} 5 metres ^{1,2}
POLE MOUNTED DISTRIBUTION TRANSFORMERS: HV and LV earths separate	15 metres	15 metres
DISTRIBUTION TRANSFORMERS ON WOOD POLES: with HV and LV earths commoned	2 metres ³ where down pole earth wire is uninsulated 1 metre ³ where down pole earth wire is insulated	15 metres
DISTRIBUTION TRANSFORMERS ON CONDUCTIVE POLES: with HV and LV earths commoned	2 metres ^{1,2}	15 metres
PAD⁴ OR GROUND DISTRIBUTION TRANSFORMERS: HV and LV earths separate fed via U/G HV cable with metal sheath back to source with HV and LV earths commoned	15 metres 5 metres ^{1,2} 2 metres ^{1,2}	15 metres 5 metres ^{1,2} 5 metres ^{1,2}
HV POLES (WOOD) WITH AIR BREAK SWITCHES: using metal operating rod using insulated operating rod	15 metres 1 metre	15 metres 1 metre
SWER TRANSFORMERS : Isolation Transformer Distribution Transformer	25 metres 15 metres	50 metres 30 metres
POLES WITH HV EARTH: e.g., HV Cable Pole Termination (Pot Head), HV Recloser, Surge Diverter	15 metres	15 metres

Standard for Distribution Earthing



HV CABLE Direct buried uninsulated sheath	0.5 metre Consult Telstra Power Coordination Tel: 1800 029 760	0.5 metre Consult Telstra Power Coordination Tel: 1800 029 760
LV EARTH	0.3 metre	1 metre
ANY OTHER POLE	1 metre	1 metre
MAJOR HV STATIONS e.g., power stations, switchyards, bulk supply substations, zone substations	Consult Telstra Power Coordination Tel: 1800 029 760	Consult Telstra Power Coordination Tel: 1800 029 760

NOTES TO THE TABLE:

1. Where possible, new HV distribution plant earths should be placed at a minimum 15 metre separation from Telstra plant listed above in columns 2 and 3. HV distribution earths at this separation are not required to meet any special conditions (e.g., bonded to MEN; HV, and LV earths commoned; etc) as listed in column 1 above. SWER HV earths are the exception as these require greater separations due to construction and load EPR considerations,
2. Where a reduced separation must be used in these cases it should be understood that its use relies upon the presence of a significant M.E.N. system and/or a specified type of power utility construction (e.g., OHEW, cable sheath return path, etc.) as detailed in column 1 above – unless these conditions can be met a minimum 15 metre separation applies,
3. Caution: The power utility shall check with DIAL BEFORE YOU DIG (PH. 1100) to obtain physical locations before undertaking excavation,
4. Ring Main Units (RMUs) have the same separation requirements as Pad Mounted Distribution Transformers,
5. Non-insulated metal sheathed Telstra cables are to be treated as for TELECOMMUNICATIONS PLANT TYPES as shown in column 2 of the table above. The codes for identifying metallic sheathed Telstra cable types are shown on page 11 of this document,
6. Insulated Telstra Cables allow closer separations than non-insulated metallic sheath cables mentioned in note 5 above. A minimum separation of 0.3 metre must be maintained between insulated (plastic sheathed or plastic jacketed) Telstra cables, (copper or optic fibre), and power utility HV or LV earthing systems excluding the HV earthing systems associated with a SWER network. A minimum separation of 1m must be maintained between the SWER HV earthing systems and insulated Telstra cables,
7. Carefully consider the type of Telstra plant likely to be affected as some types of plant are particularly difficult to mitigate or relocate (e.g., Pillars, manholes, exchanges). In these cases, cost recovery for affected plant can be substantial,
8. Some Telstra Street Mounted Equipment Housings shown on page 12 of this attachment,
9. Remote (off-site) HV Earthing systems can, on occasion, be used to mitigate the effect of EPR. See page 2 of this attachment for further information on using this approach.

Appendix C

Informative

Probabilistic Earthing Design (AS 2067, 2016).

C.1 Probabilistic Earthing Design

Late in 2016, a new edition of Standards Australia Substations and high voltage installations exceeding 1 kV a.c. (AS 2067, 2016) was released, which included major changes in how earthing is addressed in high voltage installations to promote safety of people. This document recommends changes to the distribution design process in order to comply with the requirements of the standard.

Electrically earthed items such as backyard water taps, metallic water pipes and earthed appliances are interacted with by the public on a regular basis. The complexity of evaluating the human exposure, ever changing MEN system and desire to standardise has led to oversimplifications in earthing design, or even neglect to perform an earthing design at all.

The key aspects of the 2016 edition of the standard with regards to design are that:

- Earthing systems in a HV installation must be designed (Risk ALARP/SFAIRP)
- Earthing systems must be commissioned and tested according to the design
- Earthing designs must be documented

The basic process for earthing system design is described in a flowchart in the Standards Australia Substations and high voltage installations exceeding 1 kV a.c. (AS 2067, 2016).

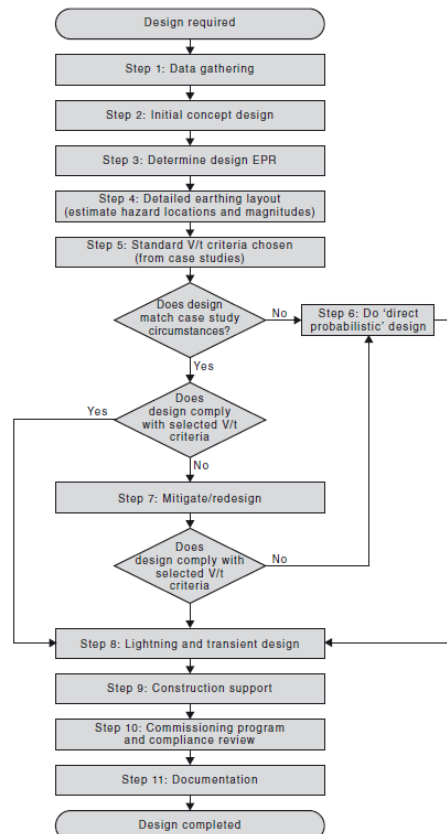

C1.1 Step 1: Data Gathering

For a distribution earthing design in the Energex area of supply, the following data shall be gathered:

- a) Points of exposure (services search, e.g., Dial Before You Dig, and neighbouring infrastructure).
- b) Site layout (e.g., structure placement).
- c) Primary and secondary power system conductor details (e.g., cable sheaths, overhead shield wires/earth wires).
- d) Fault levels and protection clearing times.
 - i. HV phase to ground fault
 - ii. HV phase to phase to ground fault
 - iii. LV phase to ground fault
 - iv. LV phase to phase to ground fault
- e) Soil resistivity and geological data.
- f) Existing earthing systems (e.g., location, test results).

C1.1.1 Fault Levels and Protection Clearing Times

In order not to incur excessive labour effort and to reduce the risk miscalculation, fault level and clearing time should come from a data source, which will need to be produced.

Soil resistivity should have a conservative assumption of 50 Ω .m used for all contact cases outside a major substation fence as recommended by the standard. This is quite a conservative value as in many instances the higher surface soil resistivity would add series impedance allowing higher perspective touch voltages.

The location of existing earthing systems should be documented if they are suspected to exist (such as MEN connections at pillars).

C1.2 Step 2: Initial Concept Design

Determine the earthing system that will likely meet the functional requirements. Detailed design is necessary to ensure that all exposed conductive parts, are earthed. Extraneous conductive parts should be earthed, if appropriate. Any structural earth electrodes associated with the installation should be bonded and form part of the earthing system. If not bonded, verification is necessary to ensure that all safety requirements are met.

The process and complexity of an earthing system design varies according to the requirements of the application. However, a number of design considerations are largely universal when designing an earthing system and their early consideration in the initial concept design phase will assist the detailed design and minimize re-design requirements.

These are detailed in the following clauses and listed as follows:

- a) Fault current and duration.
- b) Conductor sizing.
- c) Soil resistivity.
- d) Layout practicalities.

- e) Coordinated design.
- f) Current injection.
- g) Special considerations.

C.1.2.1 Fault Current

The worst case fault scenario for every relevant aspect of the functional requirements shall be determined. The following points should be considered at each voltage level present in the installation:

- a) Single phase-to-earth fault and double phase-to-earth fault conditions.
- b) Faults both within and outside the installation site, should be examined to determine the worst case earth potential rise.
- c) The combined effect of the magnitude (including d.c. offset) and duration of the fault should be used to determine the levels of stress imposed on a person or equipment (including earthing system components).
- d) While the fault level selected should be the highest which is likely to occur with allowance for future increases (e.g., future maximum that could be reasonably expected), some allowance may also be made for line and fault impedance. It is not usually appropriate to use the equipment fault short circuit rating when selecting future fault levels.
- e) Future fault level increases may be due to the following:
 - i. Installation of additional transformers or larger transformers.
 - ii. Installation of generation equipment.
 - iii. Removal of fault limitation devices such as neutral earthing resistors or reactors (NERs), earthing transformers or line reactors.
- f) System reconfiguration (e.g., new power lines which interconnect power systems).

Often only a proportion of the prospective earth fault current will return via the general mass of the earth (through the local earth grid and the soil). In some cases, fault current is diverted from the mass of the earth via cable screens, overhead earth wires, LV neutrals (MEN conductors) or other bonded conductors such as pipelines. Some of the earth fault current may also circulate within an earth grid and not contribute to the earth potential rise. Therefore, before calculating the earthing system potential rise, step voltages and touch voltages, it is important to first calculate the realistic earth return current which will be a portion of the total earth fault current.

C.1.2.2 Earth Fault Duration

- a) Personal safety

The fault clearance time of the first upstream primary protection device, e.g., primary protection time plus circuit breaker break time, total fault clearing time of a fuse) shall be used for personal safety against a worst case fault magnitude. Where High Speed Single Phase Auto Reclosing (HSSPAR) is used the clearing times for the two events (or multiple events) should be summated. HSSPAR is used on transmission lines, not on distribution lines (which typically have much longer no-voltage times between successive auto reclose attempts).

The assessment of step and touch voltage hazards often requires the consideration of a number of earth fault scenarios with different fault clearing times (other than primary). It is then necessary to evaluate which combination of fault current and clearing time represents the worst case for step and touch voltage hazards assessment. Quite often, it may be necessary to assess more than one set of fault current and fault duration scenarios.

b) Conductor sizing

Fault duration (corresponding to total clearing time) also determines the electrical rating of earthing conductors. The conductor and connecting joint thermal requirements should be of sufficient size to withstand maximum earth fault current for back-up protection operating time plus circuit breaker operating time.

C.1.2.3 Soil Resistivity

As soil resistivity and soil structure have significant effect on earth potential rise of the earthing system, care must be taken to ensure that reliable data is obtained from field testing encompassing a sufficiently wide traverse in order to establish resistivity variations with depth. Consideration shall be given to the variation of soil resistivity due to temperature and moisture.

C.1.2.4 Layout Practicalities

Where influence on property selection for a substation site is possible, data gathering in all categories listed in Section B1.1 of this document and Clause 8.4.3 of Standards Australia Substations and high voltage installations exceeding 1 kV a.c. (AS 2067, 2016). will help determine the site which best achieves a simple and effective earthing system design. Possible transferred voltage hazards may dominate site selection.

Influences which may prevent the best layout and positioning in terms of an earthing system include minimizing earthworks and the protection of vegetation, and although in the end, such influences may override gains achieved in the efficiency of the earthing system, it is important that all aspects be considered in the final decision.

C.1.2.5 Co-ordinated Design

Earthing system design should take into consideration interactions with the following systems (if applicable):

- a) Metallic pipelines.
- b) Telecommunications network.
- c) Metallic structures (e.g., fences, handrails, conveyors, industrial plant).
- d) Interconnected power earthing systems.

Note: The use of interconnected earthing system is recommended unless separation provides a lower overall risk.

C.1.2.6 Current Injection

Current injection testing may be employed during the initial design phase in order to gather information about the behaviour of existing earthing systems. This can provide a fall of potential (surface gradient) of the soil and input impedance of an existing earthing system.

C.1.2.6.1 Special Considerations

Special considerations may be necessary which include the following:

a) Staged implementation

The design must also consider any known staging requirements during the course of a project, identifying and designing out any associated touch, step and transferred potential conditions at the timing of each stage.

C1.3 Step 3: Determine Design EPR

Based upon the soil characteristics and the likely proportion of total earth fault currents flowing into the local earthing system the expected EPR is calculated for each of the key fault cases identified. This is the major outcome of the initial design concept phase as it enables assessment of which areas require further consideration. Fault scenarios that are not significant may be acknowledged and discounted from further analysis.

This first pass sets a conservative upper limit for the EPR. It enables assessment of which fault scenarios should be the focus of the detailed design effort. Some fault scenarios may later be shown to exhibit a maximum EPR that is less than the applicable compliance criteria (e.g., relevant V/t design criteria) and so achieve compliance without specific mitigation. These values are critical in that all other hazard voltages (e.g., step, touch, transfer) are calculated by scaling based on the relative EPRs for each key fault case.

C1.4 Step 4: Detailed Earthing Layout

Power frequency design

The power frequency design of an earthing system should take into account all the relevant parameters. The design parameters critical to the design include the fault current magnitude, fault current duration, soil resistivity, current splits, earth grid area, interference, and coordination. A number of the design parameters are briefly discussed below.

C.1.4.1 Earthing Conductor Layout

An earthing system bonds the required equipment and structures to the general mass of earth via some form of earth grid. The physical practicalities of the design need to achieve a level of robustness for the life of the installation. Earthing equipment and material selection is therefore critical. The method of installation and manner in which conductors are protected, the level of redundancy and the corrosion consideration employed will need to ensure the correct outcomes are achieved. The design should specify conductor sizing, terminations, acceptable jointing methods, material types, conductor protection, provision for portable earthing, labelling and inspection and testing requirements as a minimum.

Special consideration should be made to ensure the integrity of connection between critical equipment and the earthing system. Many of the provisions are addressed in some detail in other guides such as ENA Substation Earthing Guide (EG-1) (ENA DOC 045, 2022).

C.1.4.2 Dimensioning of Earth Conductors

Parameters relevant to earthing system dimensioning include magnitude and duration of fault current and soil characteristics. These parameters combine to define conductor sizing in terms of electrical and mechanical rating:

a) Electrical rating

For electrical rating, the fault currents used to calculate the conductor size should take into account the possibility of future growth. The temperature rise involved in calculating electrical rating shall be chosen to avoid reduction of the mechanical strength of the earthing system (including conductor jointing) and to avoid damage to any surrounding materials, (e.g., concrete or insulating materials).

Back-up relay protection operating time, plus circuit breaker break time should be used when designing conductor and connecting joint thermal requirements. For conductor sizing the total accumulated fault time needs to be considered where auto-reclose is applied, as there is very little cooling during the auto-reclose dead time.

Consideration may also be given to current splitting on the assumption that fault current on entering the buried section of the earth grid travels in multiple directions, and, as such, these buried conductors are not required to be rated at full fault current.

b) Mechanical rating

Externally applied forces (resulting in physical stress of the conductor) include direct impact, soil movement and compaction of surrounding soil.

Electromagnetic forces are due to the flow of fault current through the conductor and although significant, do not dictate minimum conductor size. However, where a conductor is used for down leads from mounted equipment to earth grid connection points, they shall be fastened to the structure as often as necessary to withstand the short circuit dynamic forces.

The earthing conductors, being directly in contact with the soil, shall be of materials capable of withstanding corrosion (chemical or biological attack, oxidation, formation of an electrolytic couple, electrolysis, etc.). They have to resist the mechanical influences during their installation as well as those occurring during normal service. Note that composite conductors can also be used for earthing provided that their electrical and mechanical properties are equivalent and do not compromise the integrity of the earthing system. Aluminium conductors shall not be used for buried earthing applications.

It is acceptable to use steel reinforcing bars embedded in concrete foundations and steel piles as a part of the earthing system, provided thermal ratings for conductors and joints are not exceeded.

To prevent theft and/or vandalism, consideration should be given to protecting exposed components and/or selecting alternative materials.

For direct buried or exposed conductors, a minimum size of 35 mm² copper equivalent conductor is considered prudent for high voltage earthing. Further guidance regarding sizing of conductors to meet thermal requirements is given in ENA Substation Earthing Guide (EG-1) (ENA DOC 045, 2022).

Provision for portable earthing should meet electrical and mechanical rating requirements, be located for convenient and safe usage (including putting on, taking off), and facilitate maintenance.

C.1.4.3 Transferred Potentials

Earthing systems can cause inductive and conductive interference to other metallic systems which requires coordination. Consideration shall be given to the following:

- a) Transferred potentials to plant, personnel, and the public

The substation earthing system shall be designed to ensure that interference with other utilities, plant, and personnel (e.g., telecommunications, pipelines, railways, mine infrastructure, houses, LV MEN), by conductive or inductive coupling, takes into consideration appropriate standards and guidelines.)

- b) Corrosion control

Earthing system components may be subject to corrosion from, or be the cause of corrosion in, other systems. Corrosion control coordination may also extend to the interconnection of different earthing systems comprising of different earthing materials (e.g., power station and adjacent transmission switchyard).

C.1.4.4 Hazard Location Identification

The design shall identify locations where personnel or the public may be exposed to shock hazards. Such hazards include, touch, step, transfer, and hand-to-hand contacts shown in Figure 8.2 of Standards Australia Substations and high voltage installations exceeding 1 kV a.c. (AS 2067, 2016). Hazardous step and touch voltages can appear on the metal structures or equipment associated with high voltage power systems, or may be transferred via soil, metal structures or equipment located near high voltage power systems due to one or a combination of the following factors:

- a) Electrical insulation failure or mechanical failure or both.
- b) Human error, resulting in accidental livening of station equipment, and/or lines circuits.
- c) Electric field (capacitive) coupling.
- d) Magnetic field (inductive) coupling.

Hazardous voltages on conductive parts may appear between the hand and one or both feet of a person, or between the two hands (i.e., reach touch voltages). Hazardous voltages may also appear across the surface of the ground and therefore between the feet of a person (i.e., step voltages). Such voltage differences can occur within and around HV installations, and also on metallic structures along the length of, or close to power lines, under earth fault current conditions.

Voltage differences may also need to be controlled, to ensure that insulation breakdown or failure does not occur on apparatus connected to points outside the station. Cable sheaths, metallic pipes, fences, etc. which are connected to the station earthing system will transfer earth fault voltages from the station earth electrode to the remote points. Similarly, cable sheaths, metallic pipes, etc. which are connected to remotely earthed structures but isolated from the station earth electrode will transfer the earth fault voltage of the remote structure into the station.

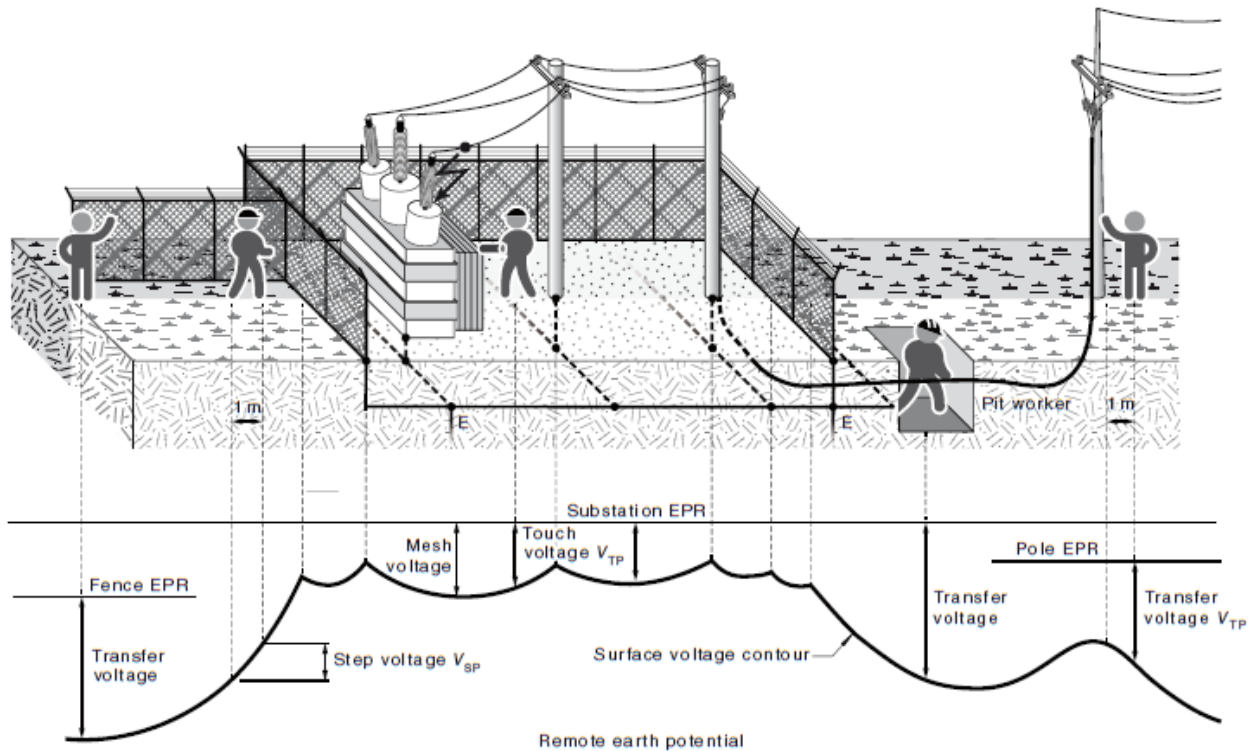

The specific hazard locations will represent different risk profiles by virtue of the fact that there will be different coincidence probabilities of system events and human contacts and different series impedance (for example, footwear and surface coverings).

Consideration should be given to factors such as the following:

- Probability of multiple simultaneous human contacts (particularly in public places), (i.e., touch, step, hand-to-hand or transfer voltage impacts).
- Susceptible locations (wet areas with little or no additional series resistance).
- Controlled access areas (fenced easements or remote areas).
- Series impedance (surface coverings and footwear).
- Future possible encroachments upon the electrical network and the effect of system events on those encroachments.
- Conductive and inductive coupling into non-power system plant such as communications infrastructure, telecoms, pipelines, and conveyors.
- Not all risk is imposed by the earthing system. There are external factors that may also impact upon the earthing system resulting in a change in the risk profile of the installation.
- Figure 8.3 of Standards Australia Substations and high voltage installations exceeding 1 kV a.c. (AS 2067, 2016), which has been reproduced below, shows the main risk elements in each category.

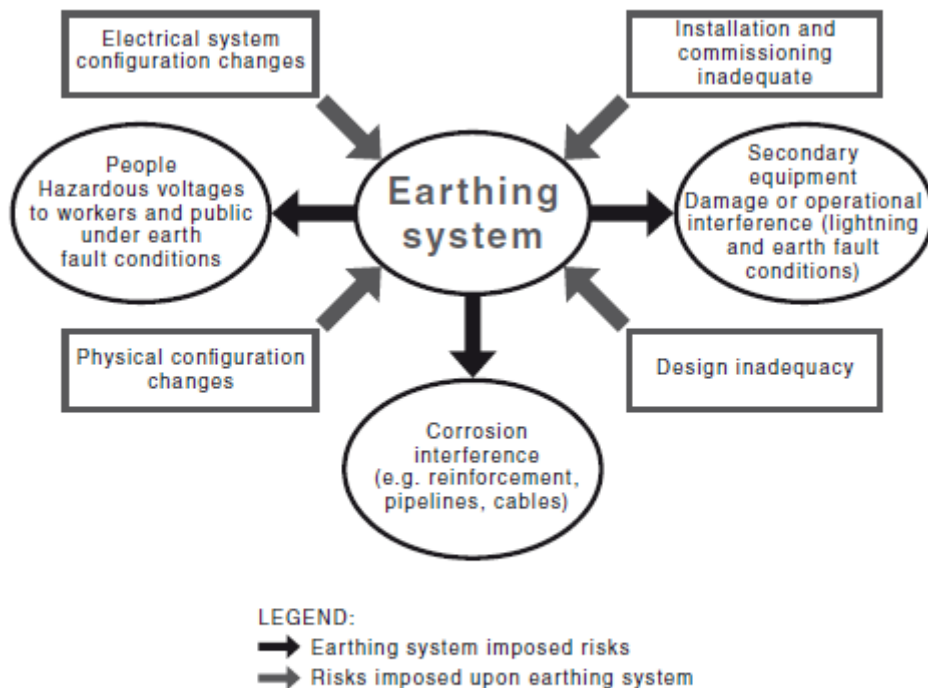

NOTE: Substation secondary equipment is associated with equipment such as SCADA, communications or protection systems.

The interaction between the substation or powerline earthing systems and secondary systems (e.g., SCADA) also needs to be considered as those systems can adversely affect each other.

C1.5 Step 5: Standard V/t Criteria Chosen (from case studies)

Based on the specifics of the design concept and the broader context, attempt to match the design to a standard voltage/time (V/t) curve or curves from the case studies. Conservative assumptions and comparisons are advisable (see Clause 8.4.7 of Standards Australia Substations and high voltage installations exceeding 1 kV a.c. (AS 2067, 2016)).

The effective management of the shock hazard requires an understanding of the ventricular fibrillation (VF) risk and of the following circumstances that make indirect electric shock accidents from earthing systems and earthed metalwork possible:

- a) Current flowing to earth of sufficient magnitude in relation to size of the earthing system and soil resistivity.
- b) Soil resistivity and distribution of earth fault current flow such that voltage gradients are possible at one or more locations.
- c) Presence of an individual at such a location, at a time, and in a position that their body bridges at least two points of different voltage.
- d) Insufficient series resistance to limit the current flow through the body (e.g., skin, shoes, gloves).
- e) Duration of the fault of sufficient time to cause harm at the given location.

As many of these variables are probabilistic in nature (Standards Australia Effects of current on human beings and livestock (Series) (AS/NZS IEC 60479)) there is no simple relation between the resistance of an earthing system as a whole, the maximum shock current to which a person might be exposed, and the likelihood of VF causing a fatality. The process for determining shock safety criteria outlined in Appendix A of Standards Australia Substations and high voltage installations exceeding 1 kV a.c. (AS 2067, 2016) enables an earthing system designer to allocate limited resources in a manner that provides a level of safety to people corresponding to the probability of a hazard occurring. The analysis recognizes realistic operating conditions and safety constraints in order to provide requirements which are both technically and economically feasible.

Consideration of appropriate safety criteria (usually a shock voltage) is required for all electrical assets that form part of the network. As hazards can be coupled to non-power system plant, particularly during earth faults, consideration shall be given to any voltages created at those locations outside the substations and easements.

Risk quantification and individually derived safety criteria

The risk profile associated with earthing systems varies greatly for different locations and circumstances. During the first phase of an earthing system design or redesign it is necessary to identify the hazard scenarios applicable to the particular site and power system configuration that could be presented during the period of the project and life of the installation/asset.

Where a design requires that a certain hazard scenario or class of hazard be mitigated and the risk reduction quantified to demonstrate due diligence, the process summarized in Appendix A of Standards Australia Substations and high voltage installations exceeding 1 kV a.c. (AS 2067, 2016) may be adopted. ENA Power System Earthing Guide (EG-0) Part 1: Management Principles (ENA DOC 025, 2022) and associated safety analysis software facilitates this process. The application of individually derived safety criteria shall be accompanied by sufficient justifying documentation.

Guidance on safety criteria

The probabilistic method in ENA Power System Earthing Guide (EG-0) Part 1: Management Principles (ENA DOC 025, 2022) describes a number of standard safety criteria curves that were produced for a given risk level. The scenarios have been selected to cover a number of cases that are commonly met by design engineers within power systems.

The value of the probabilistic method lies in being able to—

- a) identify hazard scenarios where more traditional approaches are non-conservative and more stringent criteria may be justified on account of the risk profile to which the public or operational personnel may be exposed
- b) identify hazard scenarios where the risk profile is very low and less stringent than previously adopted may be justified; and
- c) more effectively identify which design parameters are contributing to the risk profile.

This then allows the designer to undertake a risk cost benefit analysis of the various risk mitigation options.

The risk of these hazards should now be assessed by either aligning hazards with standard contact scenarios in Appendix G of Standards Australia Substations and high voltage installations exceeding 1 kV a.c. (AS 2067, 2016) (if they meet the boundary conditions) or by assessing the risk associated with a given hazard location identified.

As a guide, representative touch voltage (V_t) limits for a given risk level that may be applied to accessible metalwork for a number of typical cases not covered in the list of Standards and industry guidelines (Clause 8.4.7.4 of Standards Australia Substations and high voltage installations exceeding 1 kV a.c. (AS 2067, 2016)) are shown in Appendix G of Standards Australia Substations and high voltage installations exceeding 1 kV a.c. (AS 2067, 2016). The cases covered are as follows:

- a) Residential distribution—includes commercial sites (e.g., shopping centres), and aquatic centres (e.g., public pools)
- b) Light industrial—sawmill, batching plant, abattoir
- c) Large interconnected systems—power stations, heavy industrial, wind turbines
- d) Mining—surface plant operations
- e) Mining—underground coal
- f) Mining—underground metals
- g) Mining—open cut
- h) Mining—road tunnels – construction and operation.

The process in Appendix A of Standards Australia Substations and high voltage installations exceeding 1 kV a.c. (AS 2067, 2016) should be used to determine the level of hazard associated with voltage limits. The standard safety criteria curves provided in Appendix G of Standards Australia Substations and high voltage installations exceeding 1 kV a.c. (AS 2067, 2016) are derived using the Appendix A of Standards Australia Substations and high voltage installations exceeding 1 kV a.c. (AS 2067, 2016) process for a given risk level. For each case study the curve details (figure and equation) and assumptions governing the range of applicability have been included. If the hazard situation under consideration does not meet the case study boundary conditions, the direct probabilistic design approach outlined in Clause 8.4.8 should be performed to assess the risk or generate appropriate design curves.

The following cases are not covered in the Appendix G of Standards Australia Substations and high voltage installations exceeding 1 kV a.c. (AS 2067, 2016) case studies or the standards in Clause 8.4.7.4 of Standards Australia Substations and high voltage installations exceeding 1 kV a.c. (AS 2067, 2016) and require case specific design to be undertaken:

- a) Long overland conveyors
- b) Railway systems
- c) Theme parks.

Safety criteria within other standards and guidelines.

Safety criteria are provided within other Standards and Guidelines applicable to specific assets or hazard scenarios. Consideration should be given to the following:

- a) Metallic pipeline exposure: Standards Australia Electrical hazards on metallic pipelines (AS/NZS 4853, 2012).
- b) Telecommunications worker exposure— Standards Australia Earth potential rise - Protection of telecommunications network users, personnel, and plant (Series) (AS/NZS 3835, 2006) on earth potential rise (EPR) hazards; Standards Australia Coordination of power and telecommunications - Low Frequency Induction (LFI) - Code of practice for

the mitigation of hazardous voltages induced into telecommunications lines (HB 101, 1997) on low frequency induction (LFI) hazards.

- c) Transmission and distribution line hazards: Standards Australia Overhead line design (AS/NZS 7000, 2016).
- d) Power system plant and substations, and major substations: ENA Power System Earthing Guide (EG-0) Part 1: Management Principles (ENA DOC 025, 2022).

C1.6 Step 6: Perform Direct Probabilistic Design

In the event an identified hazard does not align with a published case study, expected fault and contact scenarios may be used to assess the probability. These can be compiled by using sources of information that may include the following: past fault records, use of models and simulations, practice and relevant experience, published literature, industry data, results of public consultations, and specialist and expert judgment.

All assumptions, boundary conditions, and design decisions determined in the analysis should be articulated in earthing system design documentations.

A direct probabilistic design uses risk boundaries to provide a range for what is considered unreasonable/intolerable and negligible for both individual and societal (i.e., multiple simultaneous) hazard exposures. ENA Power System Earthing Guide (EG-0) Part 1: Management Principles (ENA DOC 025, 2022) details an approach that enables an engineer or asset owner to assess the need to provide additional mitigation. The use of safety analysis software (e.g., Argon) enables the risk associated with voltages to be assessed for standard conditions or 'one off' situations.

C1.7 Step 7: Mitigate / Redesign

Although earthing system design procedures involve the installation of a considerable number of risk reducing measures (e.g., protection system, conductor mesh spacing) as part of earthing system design, a range of additional site specific mitigation measures and/or redesign options shall be evaluated. The selection of options should be based upon managing the specific risk associated with the step, touch and transferred voltages for identified hazard scenarios. The principles of the hierarchy of controls should be applied to the mitigation/redesign process in determining priorities (see Clause 2.7 of Standards Australia Substations and high voltage installations exceeding 1 kV a.c. (AS 2067, 2016)).

The following options may be considered for mitigation or redesign (locally or via interconnected systems):

- a) Reduction of the earth impedance of the earthing system
- b) Reduction of earth fault current using alternative system configurations, e.g., system neutral earthing via resistance or inductance, earth transformer, line reactor
- c) Reduction of earth return current, e.g., utilising inductive coupling between metallic cable sheath, earth wire and phase conductor
- d) Reduction of the fault clearing times
- e) Interconnection or separation among earthing systems, e.g., impedance connection or separation of HV and LV earth electrodes or systems
- f) Site relocation
- g) Installation of gradient control conductors

- h) Installation of non-conductive materials (e.g., timber or non-conductive poles)
- i) Installation of a barrier fence to limit access
- j) Installation of a high resistance surface layer (e.g., asphalt or crushed aggregate).
- k) Restricted access or PPE
- l) Installation of signage.

The design should be evaluated to ensure all reasonable precautions have been included, whose costs are not grossly disproportionate to the benefits. Assessment of risk mitigation is an iterative process to reduce the earthing design risk so far as is reasonably practicable (SFAIRP) or as low as reasonably practicable (ALARP).

Often a combination of the abovementioned risk mitigation treatments may be required.

Furthermore, processes, procedures and routine maintenance may be required to ensure the adequacy of proposed mitigation measures. The cost of maintenance over the life of the asset should be considered.

C1.8 Step 8: Lightning / Transient Design

Lightning and switching operations are sources of high and low frequency currents and voltages. Surges typically occur when switching reactors, back-to-back capacitors, and cables or when operating gas insulated disconnectors. Surges are able to be transferred via transformers. Lightning events, incident either directly or indirectly (i.e., via phase conductors) upon a HV Installation, may cause damage to both primary and secondary plant. Collection and dissipation of the incident energy always involves components within the earthing system. Configuring the earthing system to effectively manage this energy is one task of the design engineers. Additional guidance may be found in Standards Australia Lightning protection (AS/NZS 1768, 2021).

While earthing of secondary systems may not be the direct responsibility of the HV earthing system design engineer, incorrect coordination with the earthing and grounding of the secondary systems (i.e., protection, d.c. and a.c. auxiliary power and control wiring) may result in the following:

- a) Equipment damage (e.g., relays damaged).
- b) Operational reliability reduction (e.g., false or no CB tripping).
- c) Human safety risk (e.g., fires due to sparking in hazardous areas).

Assessing electromagnetic interference (EMI) sources, coupling mechanisms, interference levels, and resultant physical damage or operational impact regarding the impact of the earthing system configuration, should be part of the earthing system design considerations, as it is always harder to mitigate EMI risks following installation.

C1.9 Step 9: Construction Support

Earthing system construction generally involves the installation of horizontal, vertical, or inclined electrodes, buried or driven into the general mass of earth. Construction may also include connections to cable screens, equipment, structures, fences and OHEWs. During the site construction phase of the project, it should be ensured that the physical implementation of the design is compliant and installed/built to an appropriate standard/quality. Unless prescribed otherwise in the design the following recommendations apply:

- a) Chemicals should not be used to alter soil resistivity

- b) Dissimilar metals should not be used in the earthing system unless corrosion risks are properly addressed
- c) Special attention should be taken to avoid corrosion where the bare earthing conductor enters the soil or concrete
- d) Backfill should not include foreign materials
- e) Installation methods should exclude anything that increases corrosion risk
- f) The path of the earthing conductors should be as short as possible
- g) Conductors should be installed with additional protection against mechanical damage during the construction phase (where and as appropriate)
- h) Risers should be given extra consideration for mechanical protection at and around ground level and other exposed points
- i) Where inspection or testing pits are used, consideration should be given to mechanical protection, corrosion and drainage including during construction
- j) Vertical electrodes should be separated by a distance not less than the length of the electrode
- k) Vertical electrodes should be driven using appropriate tools to avoid any damage to the electrodes when driving them in. Where the stratum is too hard for the electrodes to be hand or machine driven, they may be dropped into a bored hole and care should be taken to ensure that the electrode reaches the bottom of the hole. This hole can be backfilled with suitable material that is non-corrosive and non-abrasive
- l) The joints used to assemble rods should have at least the same mechanical strength as the rods themselves and should be able to withstand mechanical stresses during driving
- m) Mechanical joints should not become loose and should be provided additional protection against corrosion as required
- n) Horizontal buried conductors should be at a depth of 0.5 m to 1 m below ground level
- o) Conductors embedded in concrete should have adequate concrete coverage to control corrosion

When construction work is connected to, or is in the area of effect of, an existing earthing system, protective measures shall be taken to protect people from electrical hazards that arise due to load or earth fault conditions. The following requirements and recommendations apply:

- a) During construction consideration should be given to exclusion zones, how power supply can be safely arranged, and how connections to or isolations from existing earthing systems, including fences, guardrails, LV neutrals and cable shields or screens, are managed.
- b) Precautions shall be taken to avoid parts of a metal framework becoming disconnected from the earthing system when temporary dismantling takes place. Such precautions may include additional earthing or bonding.
- c) Construction site management shall include earthing safety consideration of lay down areas and materials handling, particularly with respect to conductive materials of significant length and the associated conductive or inductive hazard transfer risks.

- d) Construction work associated with earthing systems that may encounter voltage hazards shall only be undertaken by staff that has suitable training, experience and site safety inductions relating to earthing safety and this shall be documented.

Note: Refer to ENA Substation Earthing Guide (EG-1) (ENA DOC 045, 2022) for further guidance.

C1.10 Step 10: Commissioning Program and Compliance Review

Review the installation for physical and safety compliance following the construction phase of the project. Ensure that the earthing system performs adequately to meet the requirements identified during the design (see Clauses 8.6 to 8.8 of Standards Australia Substations and high voltage installations exceeding 1 kV a.c. (AS 2067, 2016)).

All new or modified earthing systems shall be commissioned to validate the adequacy of the design, relevant design inputs, and installation. The plan for commissioning shall consider closely the key performance criteria identified in the hazard identification and mitigation analysis phases.

The commissioning inspection and testing plan shall prove adequacy of the earthing installation (basic material selection, installation quality and as-built drawings), as well as design criteria compliance, and provide the ongoing supervision process with benchmark or baseline figures (e.g., continuity test results).

Commissioning of the earthing system shall be performed in accordance with Clause 9.4 of Standards Australia Substations and high voltage installations exceeding 1 kV a.c. (AS 2067, 2016).

Field testing shall include visual inspection and proving continuity. Other tests may include earth resistivity testing, and current injection testing. Measurements may include the earthing system impedance, current distributions within and from the system, prospective touch and step voltages at relevant locations, and transfer voltages. Loaded voltage measurements (i.e., across a resistor simulating the body impedance) are susceptible to errors introduced by contact impedances and care should be taken to ensure contact impedances in the measurement circuit are appropriate and do not unduly dominate the measurement.

The ongoing supervision program should monitor aspects of the installation critical to maintaining safe operation and consider any 'external risks' identified during the design phase (e.g., monitoring separation distances).

The condition of the earthing system components shall be examined or assessed periodically. Visual inspection including excavation at representative locations and component testing are appropriate means. Other field activities should generally follow the commissioning program including continuity tests and measurements (and/or calculations) of the earthing system performance. These activities shall be carried out at intervals appropriate to the operating environment and operational risks of the system or following major changes to the installation or power system which affect the fundamental requirements of the earthing system.

Testing is essential as a validation step for the design, installation, and maintenance of earthing systems. In most cases tests shall measure the performance outputs of the earthing system in terms of produced voltages and current distributions rather than solely earth resistance. The testing should consider the key performance criteria identified in the hazard identification and treatment analysis phases.

Appendix D

Informative

Consideration of LFI – Flowchart Indicating Maximum Parallel Exposure before LFI is likely to exceed Acceptable Limits

The below flow chart is an excerpt from the Energex Telstra Power Coordination Guideline. The sections referenced in this flow chart refer to sections in Energex Telstra Power Coordination Guidelines.

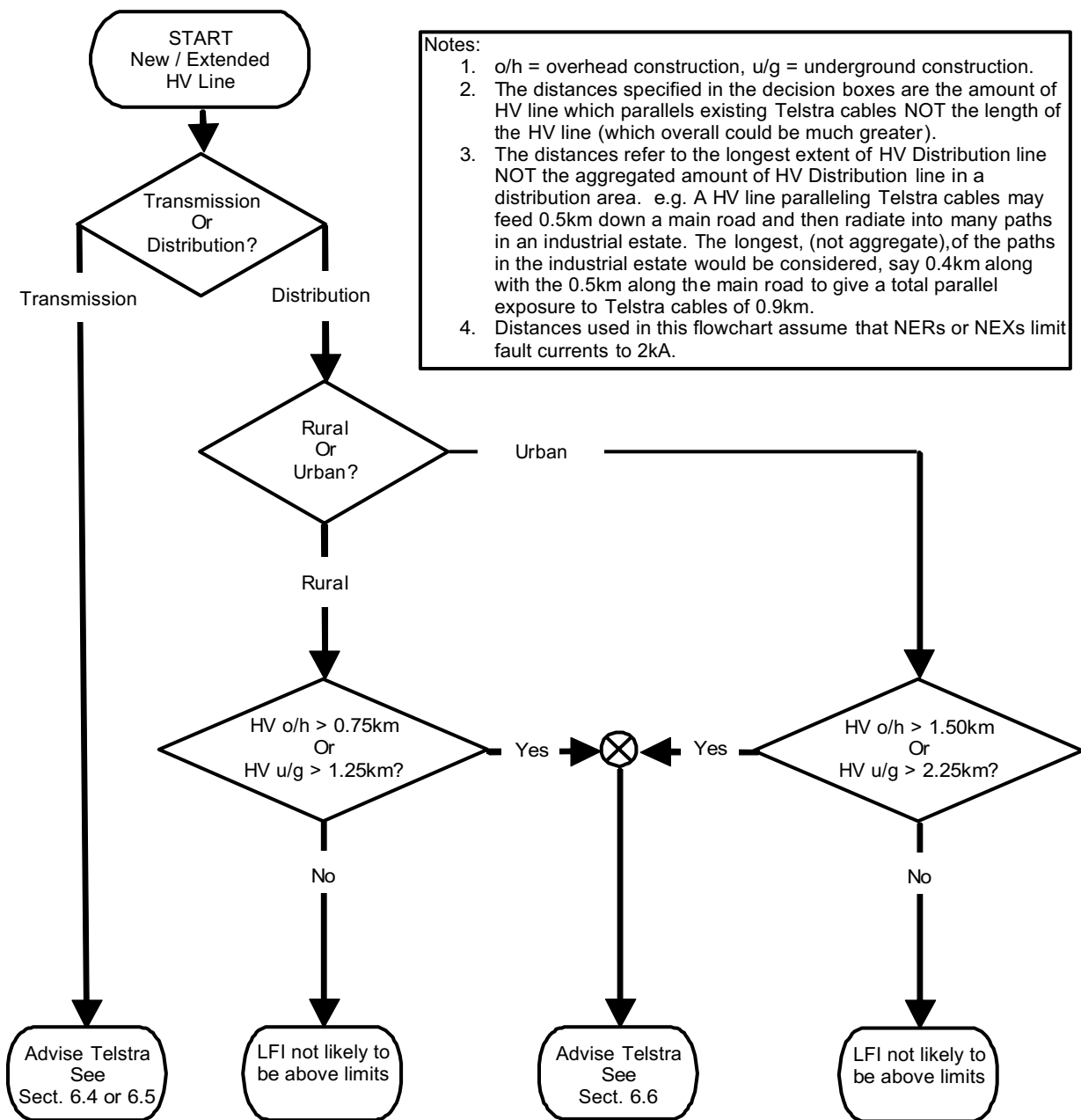

Appendix E

Informative

Summary of Distribution Equipment and Earthing Requirements

Standard for Distribution Earthing



EQUIPMENT ITEM	CMEN Areas		Separately Earthed Areas		
	Local Earth Requirements ¹	Area ² CMEN	HV Earth Requirement	LV Local Earth Requirement	Area ³ MEN
Standard Pole-Mounted Distribution Transformer	Connect all items to 30Ω max local earth and area CMEN.	1Ω max	Connect transformer tank and HV surge arresters to 30Ω max local earth. Min. 4m spacing between HV and LV earths and maximum separation of downleads on pole.	Connect LV neutral terminal and LV surge arresters (if present) to 10Ω max local earth and area MEN.	10Ω max⁴
11kV Surge Arrester	Connect all items to 30Ω max local earth and area CMEN.	1Ω max	Connect to 30Ω max local earth.	–	–
Local MEN pole or pillar	Connect all items to 30Ω max local earth and area CMEN.	1Ω max	–	Connect to 30Ω max local earth and area MEN.	10Ω max
11kV Cable Termination	Connect all items to 30Ω max local earth and area CMEN.	1Ω max	Connect 11kV cable sheath and 11kV surge arresters to 30Ω max local earth. Do not connect to LV earth – minimum 4m separation required.	Cable guard must be insulated from 11kV cable – cable must be polymeric or a split conduit installed around cable. Connect cable guard to 30Ω max local earth, and area MEN if LV exists on pole. Connect to any other metalwork at pole base (except pole reinforcing). Do not connect to 11kV earth.	10Ω max
LV Cable Termination	Connect all items to 30Ω max local earth and area CMEN.	1Ω max	–	Connect metallic cable guard to 30Ω max local earth, and area MEN. Connect to any other metalwork at pole base (except pole reinforcing). Do not connect to HV earth – minimum 4m separation required.	10Ω max
Air Break Switch Handle	Connect all items to 30Ω max local earth and area CMEN.	1Ω max	–	Connect handle to 30Ω max local earth, and area MEN if LV exists on pole. Connect to any other metalwork at pole base (except pole reinforcing). Ensure insulation in ABS downrod extends below LV. Do not connect to HV earth – minimum 4m separation required.	10Ω max

¹ “Local Earth” is the local earth grid at the site specified

² “Area CMEN” is the nearest Common MEN point in the area near the site and should be < 1 ohm.

³ “Area MEN” is the nearest MEN point in the area near the site and should be < 10 ohm for Separately Earthed Area.

⁴ For small transformers (up to 63kV.A) in remote areas (non-urban, distant from zone substation such that fault level is low) with proven high soil resistivity, up to 30Ω may be allowed.

Standard for Distribution Earthing



EQUIPMENT ITEM	CMEN Areas		Separately Earthed Areas		
	Local Earth Requirements ¹	Area ² CMEN	HV Earth Requirement	LV Local Earth Requirement	Area ³ MEN
Standard Pole-Mounted Distribution Transformer	Connect all items to 30Ω max local earth and area CMEN.	1Ω max	Connect transformer tank and HV surge arresters to 30Ω max local earth. Min. 4m spacing between HV and LV earths and maximum separation of downleads on pole.	Connect LV neutral terminal and LV surge arresters (if present) to 10Ω max local earth and area MEN.	10Ω max⁴
11kV Surge Arrester	Connect all items to 30Ω max local earth and area CMEN.	1Ω max	Connect to 30Ω max local earth.	–	–
Local MEN pole or pillar	Connect all items to 30Ω max local earth and area CMEN.	1Ω max	–	Connect to 30Ω max local earth and area MEN.	10Ω max
11kV Cable Termination	Connect all items to 30Ω max local earth and area CMEN.	1Ω max	Connect 11kV cable sheath and 11kV surge arresters to 30Ω max local earth. Do not connect to LV earth – minimum 4m separation required.	Cable guard must be insulated from 11kV cable – cable must be polymeric or a split conduit installed around cable. Connect cable guard to 30Ω max local earth, and area MEN if LV exists on pole. Connect to any other metalwork at pole base (except pole reinforcing). Do not connect to 11kV earth.	10Ω max
LV Cable Termination	Connect all items to 30Ω max local earth and area CMEN.	1Ω max	–	Connect metallic cable guard to 30Ω max local earth, and area MEN. Connect to any other metalwork at pole base (except pole reinforcing). Do not connect to HV earth – minimum 4m separation required.	10Ω max
Pole Reinforcing (Nail, Rebutt Sleeve)	Independent earth – no additional earthing required. ⁵	–	–	Independent earth – no additional earthing required.	–
SWER Distribution Transformer	N/A – <i>separate HV and LV earthing must be used.</i>	–	Connect transformer tank and HV surge arresters to local earth with two separated down leads, maximum resistance depends upon transformer size. Local earth to be comprised of	Connect LV neutral terminal and LV surge arresters (if present) to 10Ω max⁶ local earth and area MEN.	10Ω max

⁵ These items are themselves good earth electrodes. To minimise corrosion, it is preferred that these galvanized steel components are not connected to copper earthing conductors.

⁶ In areas of proven high soil resistivity, subject to a risk assessment as per *ENA Power System Earthing Guide (EG-0) Part 1: Management Principles (ENA DOC 025, 2022)* or *Standards Australia Overhead line design (AS/NZS 7000, 2016)*, individual earth electrode resistances above 10Ω may be permitted provided the area MEN resistance does not exceed 10Ω.

Standard for Distribution Earthing



EQUIPMENT ITEM	CMEN Areas		Separately Earthed Areas		
	Local Earth Requirements ¹	Area ² CMEN	HV Earth Requirement	LV Local Earth Requirement	Area ³ MEN
Standard Pole-Mounted Distribution Transformer	Connect all items to 30Ω max local earth and area CMEN.	1Ω max	Connect transformer tank and HV surge arresters to 30Ω max local earth. Min. 4m spacing between HV and LV earths and maximum separation of downloads on pole.	Connect LV neutral terminal and LV surge arresters (if present) to 10Ω max local earth and area MEN.	10Ω max⁴
11kV Surge Arrester	Connect all items to 30Ω max local earth and area CMEN.	1Ω max	Connect to 30Ω max local earth.	–	–
Local MEN pole or pillar	Connect all items to 30Ω max local earth and area CMEN.	1Ω max	–	Connect to 30Ω max local earth and area MEN.	10Ω max
11kV Cable Termination	Connect all items to 30Ω max local earth and area CMEN.	1Ω max	Connect 11kV cable sheath and 11kV surge arresters to 30Ω max local earth. Do not connect to LV earth – minimum 4m separation required.	Cable guard must be insulated from 11kV cable – cable must be polymeric or a split conduit installed around cable. Connect cable guard to 30Ω max local earth, and area MEN if LV exists on pole. Connect to any other metalwork at pole base (except pole reinforcing). Do not connect to 11kV earth.	10Ω max
LV Cable Termination	Connect all items to 30Ω max local earth and area CMEN.	1Ω max	–	Connect metallic cable guard to 30Ω max local earth, and area MEN. Connect to any other metalwork at pole base (except pole reinforcing). Do not connect to HV earth – minimum 4m separation required.	10Ω max
			≥3 electrodes spaced ≥3m apart. No disconnectable joints are permitted between HV bushing and earth. Min. 5m spacing between HV and LV earths and maximum separation of downloads on pole.		
11kV or 33kV Recloser, Regulator or Enclosed Switch	Connect all items to 30Ω max local earth and area CMEN.	1Ω max	Connect tank to 30Ω max local earth. Min. 4m spacing between HV and any LV earths and maximum separation of downloads on pole.	–	–

Standard for Distribution Earthing



EQUIPMENT ITEM	CMEN Areas		Separately Earthed Areas		
	Local Earth Requirements ¹	Area ² CMEN	HV Earth Requirement	LV Local Earth Requirement	Area ³ MEN
Standard Pole-Mounted Distribution Transformer	Connect all items to 30Ω max local earth and area CMEN.	1Ω max	Connect transformer tank and HV surge arresters to 30Ω max local earth. Min. 4m spacing between HV and LV earths and maximum separation of downleads on pole.	Connect LV neutral terminal and LV surge arresters (if present) to 10Ω max local earth and area MEN.	10Ω max⁴
11kV Surge Arrester	Connect all items to 30Ω max local earth and area CMEN.	1Ω max	Connect to 30Ω max local earth.	–	–
Local MEN pole or pillar	Connect all items to 30Ω max local earth and area CMEN.	1Ω max	–	Connect to 30Ω max local earth and area MEN.	10Ω max
11kV Cable Termination	Connect all items to 30Ω max local earth and area CMEN.	1Ω max	Connect 11kV cable sheath and 11kV surge arresters to 30Ω max local earth. Do not connect to LV earth – minimum 4m separation required.	Cable guard must be insulated from 11kV cable – cable must be polymeric or a split conduit installed around cable. Connect cable guard to 30Ω max local earth, and area MEN if LV exists on pole. Connect to any other metalwork at pole base (except pole reinforcing). Do not connect to 11kV earth.	10Ω max
LV Cable Termination	Connect all items to 30Ω max local earth and area CMEN.	1Ω max	–	Connect metallic cable guard to 30Ω max local earth, and area MEN. Connect to any other metalwork at pole base (except pole reinforcing). Do not connect to HV earth – minimum 4m separation required.	10Ω max
Steel or Concrete Pole ⁷ – LV Only	N/A	–	–	.LV earth must be bonded to pole, 30Ω max .	10Ω max

⁷ These poles are considered conductive. For concrete poles there is generally an internal connection between a local butt earth (stainless steel base plate) and an earthing ferrule. Any directly-buried conductive poles that are fully coated with an insulating compound (eg paint or epoxy) below ground must be fitted with a dedicated earth rod.

Standard for Distribution Earthing



EQUIPMENT ITEM	CMEN Areas		Separately Earthed Areas		
	Local Earth Requirements ¹	Area ² CMEN	HV Earth Requirement	LV Local Earth Requirement	Area ³ MEN
Standard Pole-Mounted Distribution Transformer	Connect all items to 30Ω max local earth and area CMEN.	1Ω max	Connect transformer tank and HV surge arresters to 30Ω max local earth. Min. 4m spacing between HV and LV earths and maximum separation of downleads on pole.	Connect LV neutral terminal and LV surge arresters (if present) to 10Ω max local earth and area MEN.	10Ω max⁴
11kV Surge Arrester	Connect all items to 30Ω max local earth and area CMEN.	1Ω max	Connect to 30Ω max local earth.	–	–
Local MEN pole or pillar	Connect all items to 30Ω max local earth and area CMEN.	1Ω max	–	Connect to 30Ω max local earth and area MEN.	10Ω max
11kV Cable Termination	Connect all items to 30Ω max local earth and area CMEN.	1Ω max	Connect 11kV cable sheath and 11kV surge arresters to 30Ω max local earth. Do not connect to LV earth – minimum 4m separation required.	Cable guard must be insulated from 11kV cable – cable must be polymeric or a split conduit installed around cable. Connect cable guard to 30Ω max local earth, and area MEN if LV exists on pole. Connect to any other metalwork at pole base (except pole reinforcing). Do not connect to 11kV earth.	10Ω max
LV Cable Termination	Connect all items to 30Ω max local earth and area CMEN.	1Ω max	–	Connect metallic cable guard to 30Ω max local earth, and area MEN. Connect to any other metalwork at pole base (except pole reinforcing). Do not connect to HV earth – minimum 4m separation required.	10Ω max
teel or Concrete Pole – 11kV Only	An earth wire linking the pole to the area MEN is required for CMEN configuration. Connect pole and all items to 30Ω max local earth and area CMEN.	1Ω max	Except for <i>Remote</i> (non-urban) <i>Locations</i> ⁸ , conduct a risk-based assessment ⁹ .	–	–

⁸ Except for *Remote* means *Frequented* or *Special Locations*. *Special locations* include school grounds, playgrounds, public swimming pool areas, beaches, water recreation areas or public thoroughfares within 100m of the above-named areas.

⁹ The non-standard earthing arrangement must comply with *ENA Power System Earthing Guide (EG-0) Part 1: Management Principles (ENA DOC 025, 2022)* or *Standards Australia Overhead line design (AS/NZS 7000, 2016)*. Mitigation measures such as pole base insulation or grading rings may be required.

Standard for Distribution Earthing



EQUIPMENT ITEM	CMEN Areas		Separately Earthed Areas		
	Local Earth Requirements ¹	Area ² CMEN	HV Earth Requirement	LV Local Earth Requirement	Area ³ MEN
Standard Pole-Mounted Distribution Transformer	Connect all items to 30Ω max local earth and area CMEN.	1Ω max	Connect transformer tank and HV surge arresters to 30Ω max local earth. Min. 4m spacing between HV and LV earths and maximum separation of downleads on pole.	Connect LV neutral terminal and LV surge arresters (if present) to 10Ω max local earth and area MEN.	10Ω max⁴
11kV Surge Arrester	Connect all items to 30Ω max local earth and area CMEN.	1Ω max	Connect to 30Ω max local earth.	–	–
Local MEN pole or pillar	Connect all items to 30Ω max local earth and area CMEN.	1Ω max	–	Connect to 30Ω max local earth and area MEN.	10Ω max
11kV Cable Termination	Connect all items to 30Ω max local earth and area CMEN.	1Ω max	Connect 11kV cable sheath and 11kV surge arresters to 30Ω max local earth. Do not connect to LV earth – minimum 4m separation required.	Cable guard must be insulated from 11kV cable – cable must be polymeric or a split conduit installed around cable. Connect cable guard to 30Ω max local earth, and area MEN if LV exists on pole. Connect to any other metalwork at pole base (except pole reinforcing). Do not connect to 11kV earth.	10Ω max
LV Cable Termination	Connect all items to 30Ω max local earth and area CMEN.	1Ω max	–	Connect metallic cable guard to 30Ω max local earth, and area MEN. Connect to any other metalwork at pole base (except pole reinforcing). Do not connect to HV earth – minimum 4m separation required.	10Ω max
Steel or Concrete Pole – 11kV and LV	Connect pole and all items to 30Ω max local earth and area CMEN.	1Ω max	Except for <i>Remote</i> (non-urban) <i>Locations</i> , conduct a risk-based assessment.	LV earth must not be in direct contact with pole and minimum separation of 4m from pole to LV earth electrodes LV earths/neutral must be insulated from pole, e.g., use LVABC or timber LV cross-arm, and LV earth downleads in conduit.	10Ω max
33kV with Overhead Earth Wire (OHEW) on Timber Pole ¹⁰	Connect 33kV earth to separate 30Ω max local earth at least 4m from CMEN earth.	1Ω max	Connect 33kV and 11kV earths to 10Ω max local earth. Min. 4m spacing from any LV earths	Connect to any LV earths to local earth electrode and area MEN.	10Ω max

¹⁰ In special cases where a conflict exists between OHEW earthing and other earths, the OHEW downlead may be omitted on a pole provided that adjacent poles have OHEW connected to earth.

Standard for Distribution Earthing



EQUIPMENT ITEM	CMEN Areas		Separately Earthed Areas		
	Local Earth Requirements ¹	Area ² CMEN	HV Earth Requirement	LV Local Earth Requirement	Area ³ MEN
Standard Pole-Mounted Distribution Transformer	Connect all items to 30Ω max local earth and area CMEN.	1Ω max	Connect transformer tank and HV surge arresters to 30Ω max local earth. Min. 4m spacing between HV and LV earths and maximum separation of downleads on pole.	Connect LV neutral terminal and LV surge arresters (if present) to 10Ω max local earth and area MEN.	10Ω max⁴
11kV Surge Arrester	Connect all items to 30Ω max local earth and area CMEN.	1Ω max	Connect to 30Ω max local earth.	–	–
Local MEN pole or pillar	Connect all items to 30Ω max local earth and area CMEN.	1Ω max	–	Connect to 30Ω max local earth and area MEN.	10Ω max
11kV Cable Termination	Connect all items to 30Ω max local earth and area CMEN.	1Ω max	Connect 11kV cable sheath and 11kV surge arresters to 30Ω max local earth. Do not connect to LV earth – minimum 4m separation required.	Cable guard must be insulated from 11kV cable – cable must be polymeric or a split conduit installed around cable. Connect cable guard to 30Ω max local earth, and area MEN if LV exists on pole. Connect to any other metalwork at pole base (except pole reinforcing). Do not connect to 11kV earth.	10Ω max
LV Cable Termination	Connect all items to 30Ω max local earth and area CMEN.	1Ω max	–	Connect metallic cable guard to 30Ω max local earth, and area MEN. Connect to any other metalwork at pole base (except pole reinforcing). Do not connect to HV earth – minimum 4m separation required.	10Ω max
	11kV and LV items connected in accordance with CMEN requirement.		required, and maximum separation of downleads on pole.		
33kV with Overhead Earth Wire (OHEW) on Concrete/Steel Pole ⁸	Connect all 33kV, 11kV and LV items to 10Ω max local earth and area CMEN. Avoid use of LV on these poles. If LV is present preferred option is LVABC.	1Ω max	Except for remote (non-urban) locations, pole base insulation is required to 2.4m from ground or special earthing design required.	LV earths/neutral must be insulated from pole, e.g., use LVABC or timber LV cross-arm, and LV earth downleads in conduit.	10Ω max

Standard for Distribution Earthing



EQUIPMENT ITEM	CMEN Areas		Separately Earthed Areas		
	Local Earth Requirements ¹	Area ² CMEN	HV Earth Requirement	LV Local Earth Requirement	Area ³ MEN
Standard Pole-Mounted Distribution Transformer	Connect all items to 30Ω max local earth and area CMEN.	1Ω max	Connect transformer tank and HV surge arresters to 30Ω max local earth. Min. 4m spacing between HV and LV earths and maximum separation of downleads on pole.	Connect LV neutral terminal and LV surge arresters (if present) to 10Ω max local earth and area MEN.	10Ω max⁴
11kV Surge Arrester	Connect all items to 30Ω max local earth and area CMEN.	1Ω max	Connect to 30Ω max local earth.	–	–
Local MEN pole or pillar	Connect all items to 30Ω max local earth and area CMEN.	1Ω max	–	Connect to 30Ω max local earth and area MEN.	10Ω max
11kV Cable Termination	Connect all items to 30Ω max local earth and area CMEN.	1Ω max	Connect 11kV cable sheath and 11kV surge arresters to 30Ω max local earth. Do not connect to LV earth – minimum 4m separation required.	Cable guard must be insulated from 11kV cable – cable must be polymeric or a split conduit installed around cable. Connect cable guard to 30Ω max local earth, and area MEN if LV exists on pole. Connect to any other metalwork at pole base (except pole reinforcing). Do not connect to 11kV earth.	10Ω max
LV Cable Termination	Connect all items to 30Ω max local earth and area CMEN.	1Ω max	–	Connect metallic cable guard to 30Ω max local earth, and area MEN. Connect to any other metalwork at pole base (except pole reinforcing). Do not connect to HV earth – minimum 4m separation required.	10Ω max
HVABC	Connect catenary and sheaths to 30Ω max local earth and area CMEN.	1Ω max	Connect 11kV catenary and sheaths to 30Ω max local earth. Min. 4m spacing between HV and any LV earths and maximum separation of downleads on pole.		–
Transmission Poles	No 11kV or LV earths are permitted on these poles. Consequently, no 11kV plant can be mounted on these poles, and LV earths/neutral must be insulated from the pole, e.g., use LVABC or timber LV cross-arm. Except for <i>Remote</i> (non-urban) <i>Locations</i> , for steel or concrete poles, insulation is required to 2.4m from ground or non-standard earthing design required.				
Padmount Transformer	Connect all items to 10Ω max local earth and area CMEN.	1Ω max	Connect transformer tank and HV surge arresters to 10Ω max local earth ring. Min. 5m separation from any structure/building	Connect to 10Ω max local earth and area MEN with min. 5m separation from HV earth ring.	10Ω max

Standard for Distribution Earthing



EQUIPMENT ITEM	CMEN Areas		Separately Earthed Areas		
	Local Earth Requirements ¹	Area ² CMEN	HV Earth Requirement	LV Local Earth Requirement	Area ³ MEN
Standard Pole-Mounted Distribution Transformer	Connect all items to 30Ω max local earth and area CMEN.	1Ω max	Connect transformer tank and HV surge arresters to 30Ω max local earth. Min. 4m spacing between HV and LV earths and maximum separation of downleads on pole.	Connect LV neutral terminal and LV surge arresters (if present) to 10Ω max local earth and area MEN.	10Ω max⁴
11kV Surge Arrester	Connect all items to 30Ω max local earth and area CMEN.	1Ω max	Connect to 30Ω max local earth.	–	–
Local MEN pole or pillar	Connect all items to 30Ω max local earth and area CMEN.	1Ω max	–	Connect to 30Ω max local earth and area MEN.	10Ω max
11kV Cable Termination	Connect all items to 30Ω max local earth and area CMEN.	1Ω max	Connect 11kV cable sheath and 11kV surge arresters to 30Ω max local earth. Do not connect to LV earth – minimum 4m separation required.	Cable guard must be insulated from 11kV cable – cable must be polymeric or a split conduit installed around cable. Connect cable guard to 30Ω max local earth, and area MEN if LV exists on pole. Connect to any other metalwork at pole base (except pole reinforcing). Do not connect to 11kV earth.	10Ω max
LV Cable Termination	Connect all items to 30Ω max local earth and area CMEN.	1Ω max	–	Connect metallic cable guard to 30Ω max local earth, and area MEN. Connect to any other metalwork at pole base (except pole reinforcing). Do not connect to HV earth – minimum 4m separation required.	10Ω max
Outdoor Ground substation	Connect all items to 10Ω max local earth and area CMEN.	1Ω max	Connect transformer tank to 10Ω max local earth. Min. 5m separation from any structure/building	Connect LV neutral terminal to 10Ω max local earth and area MEN with min. 5m separation from HV earth ring.	10Ω max
Indoor Distribution Substations	10Ω max local earth and area CMEN. Connect two down leads to earth mat if substation is not on level directly above ground.	1Ω max	N/A – <i>separate HV and LV earthing must not be used.</i>	–	–
Free-standing 11kV RMU or ground-mounted switch	Connect all items to 10Ω max local earth and area CMEN.	1Ω max	Connect tank to 10Ω max local earth. Min. 5m separation between HV earth and any structure/building or LV earth and maximum separation of downleads on pole.	–	–

00758

Standard for Distribution Earthing

Appendix F

Informative

Disclaimer

Disclaimer This document has been developed using information provided by Energex Construction, Planning and Design staff and as such is suitable for most situations encountered. The requirements of Australian Standards, Building Codes and all other statutory bodies are regarded as the accepted minimum requirements for the establishment of these substations. Where this document exceeds those requirements, this document is to become the accepted minimum. Energex will not accept any liability for work carried out to a superseded standard. Energex may not accept work carried out that is not in accordance with current standard requirements. Energex manuals are subject to ongoing review. If conflict exists between manuals, the requirements of the most recent manual are to be adopted. A proprietary item is any item identified by graphic representation on the drawings, or by naming one or more of the following: manufacturer, supplier, installer, trade name, brand name, catalogue or reference number, and the like. The identification of a proprietary item is a recommendation ONLY. It indicates the required properties of the item, such as the type, quality, appearance, finish, method of construction and performance. More than one supplier or product is capable of meeting this Specification. An alternative/ equivalent item is permissible, provided that it meets the relevant performance criteria and is otherwise of a quality reasonably satisfactory to Energex. No claim shall arise from any rejection by Energex of an alternative/equivalent item. The acceptance of an alternative/equivalent item shall not be grounds for a variation to cost or time. When offering an alternative/equivalent item, the Contractor is to provide all available technical information, and any other relevant information requested by Energex. If requested by Energex, the Contractor is to obtain and submit reports on relevant tests by an independent testing authority.

Deviation Any proposed deviation from this document must be submitted to Energex in writing with full descriptions and details for approval before it is implemented. Allowance should be made to ensure Energex is provided with sufficient time for full and in-depth consultation and deliberation.

Interpretation In the event that any user of this manual considers the content uncertain, ambiguous, or otherwise in need of interpretation, the user may request Energex to clarify the provision. Should further review be required, the provisions of the previous clause "Deviation" will need to be followed.

Updates & Subscription When downloaded or printed, this document is uncontrolled. This document is subject to amendment by Energex at any time. Users are responsible for ensuring they are using the latest information.