



Part of the Energy Queensland Group

EARTHING OF HIGH VOLTAGE ELECTRICAL APPARATUS FOR THE PROTECTION OF PERSONNEL

Earthing of High Voltage Electrical Apparatus for the Protection of Personnel

REVISION HISTORY

Revision date	Version number	Author	Description of change/revision
17/10/17	v9.0	NOS Team	Original published version
02/02/18	V10	NOS Team	Corrected drawing in Section 7.3.2, 7.4.3, 7.4.6 and 7.10.3. Fixed revision history for published versions (now aligned between beacon and source).

DOCUMENT APPROVALS

Name	Position title	Signature	Date
Russell Gordon	Manager Network Operations Standards and Engineering	Signed	16/02/2018
Charlie Gianoulis	Principal System Operations Engineer RPEQ # 16734	Signed	14/02/2018

Earthing of High Voltage Electrical Apparatus for the Protection of Personnel



Part of the Energy Queensland Group

1.	OVERVIEW.....	1
1.1.	PURPOSE	1
1.2.	SCOPE	1
2.	REFERENCES.....	2
2.1.	ENERGEX CONTROLLED DOCUMENTS	2
2.1.	ERGON ENERGY CONTROLLED DOCUMENTS	2
2.2.	OTHER DOCUMENTS	2
3.	LEGISLATION, REGULATIONS, RULES AND CODES	3
4.	DEFINITIONS, ABBREVIATIONS AND ACRONYMS	3
4.1.	GENERAL.....	3
4.2.	ENERGEX	4
4.3.	ERGON ENERGY	4
5.	GENERAL EARTHING REQUIREMENTS	4
6.	EARTHING OF HV ELECTRICAL APPARATUS	7
6.1.	OPERATOR EARTHS	7
6.2.	WORKING EARTHS	8
6.3.	HAZARDS & RISKS DUE TO INDUCED VOLTAGES AND CURRENTS.....	9
7.	EARTHING REQUIREMENTS FOR SPECIFIC HIGH VOLTAGE ELECTRICAL APPARATUS	12
7.1.	LEGEND OF SYMBOLS.....	12
7.2.	EARTHING OF TRANSMISSION LINES/SUB TRANSMISSION LINES	13
7.3.	EARTHING OF TRANSMISSION / SUB TRANSMISSION LINES BETWEEN INTERCONNECTED SUBSTATIONS	14
7.4.	EARTHING OF ZONE SUBSTATION APPARATUS AND TRANSMISSION/SUB TRANSMISSION LINES	17
7.5.	EARTHING OF HV METAL CLAD SWITCHGEAR AND BUSBARS.....	23
7.6.	EARTHING OF EXPOSED HV OUTDOOR BUSBARS	23
7.7.	EARTHING OF HV TRANSFORMERS AND REGULATORS	23
7.8.	EARTHING OF AUDIO FREQUENCY LOAD CONTROL (AFLC) INJECTION EQUIPMENT	24
7.9.	EARTHING OF CAPACITOR BANKS	25
7.10.	EARTHING OF NEUTRAL EARTHING RESISTORS (NER) / NEUTRAL EARTHING REACTORS (NEX).....	29
7.11.	EARTHING OF HV UNDERGROUND CABLES.....	32
7.12.	EARTHING OF RING MAIN UNITS (RMU)	34
7.13.	OVERHEAD DISTRIBUTION SYSTEM INTERCONNECTED/RING/MESHED	35
7.14.	OVERHEAD DISTRIBUTION SYSTEM RADIAL	38
7.15.	SINGLE WIRE EARTH RETURN (SWER) SYSTEMS	40
8.	Assessing Working Earth Requirements.....	44
8.1.	FLOWCHART	44
8.2.	INSTRUCTION	45
9.	Non-Commissioned/Decommissioned Electrical Apparatus	48
9.1.	MANAGEMENT OF INDUCTION HAZARDS & RISKS	48
10.	Assessing Non-Commissioned & Decommissioned Earthing Requirements.....	49
10.1.	FLOWCHART	50
10.2.	INSTRUCTION	51

Check this is the latest version before use.

EX RED 01732 Ver 10
EE P53K05R01 Ver 10

Earthing of High Voltage Electrical Apparatus for the Protection of Personnel

1. OVERVIEW

1.1. Purpose

The purpose of this document is to provide guidelines for the minimum earthing requirements for the protection of personnel working on or near commissioned High Voltage (HV) Electrical Apparatus isolated for the issue of an Access Permit/Test Permit (AP/TP) and/or relevant Authorities/Notices. It is supplemented with guidelines for earthing non-commissioned /decommissioned electrical apparatus.

NOTE: *It is a requirement of the QLD Electricity Safety Act and Regulations, that work (excluding HV Live Work) which involves persons coming into direct contact with or within the prescribed exclusion zone limits for exposed High Voltage Electrical Parts may only be performed if the High Voltage Electrical Parts are earthed.*

1.2. Scope

The intended audience for this document are trained and authorised Electricity Entity personnel. It is provided as a guide for the application of operator earths and working earths on HV electrical apparatus on the Ergon Energy and Energex networks and shall be used in conjunction with the Queensland Electricity Entity Standard for Safe Access to High Voltage Electrical Apparatus (SAHV/QEESSAHVEA).

The examples provided are not exhaustive but aim to illustrate the principles for the minimum earthing requirements in commonly encountered scenarios. Until Electricity Entity systems, training, authorisations and relevant Standard Work Practices (SWPs) are aligned there will be specific differences between the procedures that are used in the **Ergon Energy** and **Energex** geographical areas and where applicable these differences are recorded.

This document contains:

- Examples of specific situations to provide a guide for the minimum earthing requirements where access to HV electrical apparatus is required;
- Examples relate to both Ergon Energy and Energex unless otherwise specified as *Ergon Only* or *Energex Only*.
- A guide to the minimum requirements for the placement of operator earths when completing and processing applications for work and for the writing and checking of switching schedules/sheets;
- A guide to the minimum requirements for the placement of working earths for risk assessment and implementation of control measures at the work area;
- Mandatory legislative and business requirements;
- Supplemented guidelines for earthing of non-commissioned/de-commissioned apparatus.

NOTE: *Prior to performing any of the earthing practices covered by this document, all relevant Electricity Entity procedures and SWPs shall be followed. The diagrams shown are to be used as a guide only and any isolation, earthing and access to the Ergon Energy and Energex networks shall be individually assessed to ensure the adequacy of safety precautions at all times.*

Earthing of High Voltage Electrical Apparatus for the Protection of Personnel

It is the responsibility of an authorised Recipient to assess and determine the location of any working earths required to suit the progress of work when working on isolated HV electrical apparatus.

2. REFERENCES

2.1. Energex Controlled Documents

Document Number or Location	Document Name	Document Type
RED 00301	Operating Practices Manual – Section 11 Commissioning/Decommissioning Procedures	Manual
WP1301	Capacitor Bank Maintenance and Corrective Repair	Work Practice
WP9607	Test to Prove De-energised and Earth (OH Mains and Apparatus)	Work Practice
WP1314	High Voltage Live Work Manual Section 8.10	Work Practice
WP9690	Neutral Earthing Resistor Maintenance	Work Practice
WP9450	Positive Identification and Working on Underground High Voltage Cables	Work Practice

2.2. Ergon Energy Controlled Documents

Document Number or Location	Document Name	Document Type
ST0301	Apply and Remove Portable Earthing Devices	Standard Work Practice
SP0311	Temporary Removal of Operator Earths	Standard Work Practice

2.3. Other Documents

Document Number or Location	Document Name	Document Type
Energex: 00376 Ergon Energy: Orange Book	Queensland Electricity Entity Standard for Safe Access to High Voltage Electrical Apparatus (SAHV)	Standard

Earthing of High Voltage Electrical Apparatus for the Protection of Personnel

3. LEGISLATION, REGULATIONS, RULES AND CODES

Legislation, regulations, rules, and codes
QLD Electrical Safety Act 2002
QLD Electricity Regulation 2006
Work Health and Safety Act 2011 (QLD)

4. DEFINITIONS, ABBREVIATIONS AND ACRONYMS

4.1. General

Term	Definition
Reasonably practicable / reasonable and practicable	<p>Reasonably practicable (or reasonable and practicable) means that which is, or was at a particular time, reasonably able to be done in relation to ensuring health and safety, taking into account and weighing up all relevant matters including -</p> <ul style="list-style-type: none"> a) the likelihood of the hazard or the risk concerned occurring; and b) the degree of harm that might result from the hazard or the risk; and c) what the person concerned knows, or ought reasonably to know, about - <ul style="list-style-type: none"> i. the hazard or the risk; and ii. ways of eliminating or minimising the risk; and d) the availability and suitability of ways to eliminate or minimise the risk; and e) after assessing the extent of the risk and the available ways of eliminating or minimising the risk, the cost associated with available ways of eliminating or minimising the risk, including whether the cost is grossly disproportionate to the risk. <p>Extract: <i>Work Health and Safety Act 2011 (Qld) Part 2, Div 1, Sub-Div 2</i></p>
Short Circuit Current	Current resulting from a short circuit due to a fault or an incorrect connection in an electric circuit also known as Fault Current.

Earthing of High Voltage Electrical Apparatus for the Protection of Personnel

4.2. Energex

Definitions

[Energex Business Glossary](#)

4.3. Ergon Energy

Definitions

[P53H05R03 Switching and Access Definitions](#)

5. GENERAL EARTHING REQUIREMENTS

The purpose of earthing is:

- a) To enable protection to operate.
- b) To limit the rise in potential difference and safely discharge induced or residual voltage at the work area or site.

The following are the general principles and requirements that shall be applied when earthing of HV electrical apparatus is to be carried out:

1. Where reasonable and practicable, continuity of earthing shall be confirmed and maintained for the duration of work on any HV electrical apparatus.
2. Equipment winding configurations shall be taken into account when assessing earth continuity e.g. SWER Isolating Transformers or Power Transformers.
 - Auto-Transformers and Voltage Regulators are considered to have a continuous circuit.
 - The primary conductor of a current transformer is considered solid and continuous.
3. Stored energy sources such as load control units and capacitor banks shall be discharged and approved bridging leads or earths applied prior to any work being carried out under an AP/TP to prevent potential recharging during the duration of the work. This shall be carried out in accordance with documented SWPs, switching schedules/sheets or other pre-prepared methods (**see [Section 7.8 Earthing of AFLC](#) and [7.9 Earthing of Capacitor Banks](#)**).
4. Where open points are created for de-loading purposes, affecting the earthing continuity of the area to be accessed, switching operations shall ensure all section/s of line and apparatus within the work area are tested, proven de-energised and operator earths applied prior to the issue of any relevant Permits/Notices. (This may also be achieved by closing the opened de-loading points prior to any operation to test to prove de-energised and apply operator earths).
5. Workers should attempt to work in a zone of equipotential for the duration of work on any HV electrical apparatus. If an open point is created in the HV apparatus under access, where reasonable and practicable, working earths are to be applied to both sides of the break and connected to a common earthing point or approved bridging leads used. Most importantly, no worker should contact two different potentials at the same time.

Earthing of High Voltage Electrical Apparatus for the Protection of Personnel

6. Earths shall be applied as close as reasonably practicable to any persons required to work on the isolated system so that where reasonable and practicable (e.g. Overhead system) the earths are within sight of such persons.
7. Work on isolated HV electrical apparatus shall be carried out between earths where reasonable and practicable.
8. Recipients or Individuals of Workgroup that are not electrically licenced, are not permitted to place or remove earths, and earths shall always be visible from the work area. The applicant shall scope the job to ensure that adequate earthing arrangements are in place before an access permit is issued and for the duration of the work. All earths shall be placed as items on the related switching sheet as operator earths.
9. Earths placed in conjunction with isolation carried out for Customers for the issue of a Customer Authority/Notice may be placed or removed at the request of a Customer Representative with the approval of a Switching Co-ordinator in accordance with approved procedures.
10. Where reasonable and practicable HV electrical apparatus shall be tested to prove de-energised at the proposed point of application of Earths.
11. All phases shall be proven de-energised using an approved voltage detector before earths are applied. Correct operation of the voltage detector shall be verified immediately before and after proving de-energised. Note that the voltage detector may indicate the presence of voltage due to induction. If voltage is detected, cease work immediately and contact the Switching Co-ordinator.
12. Earths shall be applied immediately after proving de-energised. All de-energised phases shall be earthed. Tail(s) of Portable Earthing Devices (PEDs) shall be connected to earth before application to the electrical apparatus.
13. Where the design of HV electrical apparatus does not allow testing to prove de-energised, HV electrical apparatus with fault make earthing capabilities shall be used after first checking other voltage or mechanical indicating devices that HV electrical apparatus is de-energised. Where both voltage and mechanical indicating devices are available, both shall be checked that they indicate the electrical apparatus is de-energised prior to earthing.
14. It is preferable to use an earth switch in lieu of PEDs where reasonable and practicable. Where an earth switch is available, it is preferable to close the earth switch prior to applying or removing PEDs.
15. If using metal clad switchgear/Circuit Breaker (CB) in the closed position to earth Electrical Apparatus for the issue of an AP/TP, the CB shall be made inoperable. Where the CB is used as part of operator earthing circuit, it must be listed as a Safety Precaution in the switching schedule/sheet and AP/TP.
However, when performing switching prior to the issue of an AP/TP, earthing through any CB is permissible without making the CB inoperable e.g. closing CBs to provide a discharge path to earth for transformer ended cables prior to applying PEDs.
16. When Overhead High Voltage lines are to be earthed to a temporarily driven earth electrode, special precautions shall be taken to mitigate the impact of step and touch potentials, where reasonable and practicable. Such as during the discharging and earthing operation, no person other than the one applying the earth shall approach within 6 metres of any temporarily driven earth electrode or its connections or of the ladders, poles or structures from which an earthing device is applied.

Earthing of High Voltage Electrical Apparatus for the Protection of Personnel

17. Where a set of single-phase PEDs is installed at the work area, all phases of the PEDs shall be connected individually to the same earthing point. In substations where it may not be possible to connect to a single earth point due to the design, a suitably rated connection to an earth grid shall be used.
18. Where PEDs are already in place from previous work, the test date and condition shall be checked and if out of date/not fit for service, the Switching Co-ordinator shall be contacted to have them replaced or removed.
19. A PED shall be withdrawn from service, tagged out of service and sent for testing if:
 - If the next test date has expired.
 - There is any mechanical damage.
 - They have been exposed to any fault current.
20. Where multiple APs are issued within the same isolated area, the Recipient of each permit shall consider the potential of compromising the continuity of earthing by all work tasks being performed in the isolated area by the other groups, when conducting their risk assessment to determine working earth requirements.
21. Where the work under an AP/TP involves the connection, cutting or disconnection of HV conductors, then approved bridging leads shall be applied across the proposed conductor break, or PEDs shall be applied either side of (and as close as reasonably practicable to) the proposed break and individually connected to a common earthing point before the break is created. Failure to do so may lead to serious injury or death.
22. Earths shall be in place on electrical apparatus prior to and during the placement and removal of test leads. Where the design of the electrical apparatus does not allow this, approved Electricity Entity procedures shall be used.
23. Where the design or configuration of specific apparatus requires earthing practices not covered in this document, a documented risk assessment and method of earthing shall be developed, endorsed and approved by an appropriately qualified and authorised electrical engineer (RPEQ Engineer).

Earthing of High Voltage Electrical Apparatus for the Protection of Personnel

6. EARTHING OF HV ELECTRICAL APPARATUS

6.1. Operator Earths

Devices used for operator earths shall be adequate for the fault current at the specific location and shall enable protection equipment to operate.

An operator earth shall be placed between the work area and any HV source of supply. Where this cannot be achieved refer to [Item 23 of General Earthing Requirements](#).

The placement or removal of an operator earth shall only be carried out if one of the following occurs:

- Under the direction of a switching schedule/sheet with the approval of a Switching Co-ordinator;
- Under the direction of a Recipient of a TP;
- Under the direction of a Recipient of an AP with the approval of a Switching Co-ordinator in accordance with approved procedures;

NOTE: *Operator earths applied for an AP shall remain in place as required except when required to be temporarily removed to allow testing involving non-lethal current or progress of work. They shall be replaced as soon as reasonably practicable on the completion of the work or testing involving non-lethal current. Where reasonable and practicable, operator earths associated with an AP/TP shall be restored before an AP/TP is surrendered.*

When restoration of operator earths is not reasonable and practicable, the Recipient shall obtain approval from the Switching Co-ordinator to leave nominated operator earths removed. On approval, the Recipient shall record details of all operator earth. If the location of operator earths change or are to be changed during the course of work under an AP/TP, then prior to operator earths being changed, all relevant AP/TPs shall be surrendered and cancelled and new AP/TPs issued to reflect the new location/s of operator earths. All switching schedules/sheets shall be amended to reflect any changes made.

An operator earth shall be clearly identified by the attachment of a Do Not Operate Board (DNOB) in a prominent position. **This is the prime, visible, distinction between an operator earth and a working earth.**

For three-phase PEDs (trifurcated earth), one DNOB shall be attached at the point of common connection of the 3 phases of the PEDs to the earth tail.

For single-phase earths, a DNOB shall be attached in a prominent position to each earth lead.

Operator earths shall be connected to HV conductors at location(s) that shall enable protection equipment to operate and the work area to be de-energised in the event of inadvertent re-energisation.

Operator earths shall be applied to ensure HV electrical apparatus in the area where a work area is to be established is earthed prior to issue of AP/TP.

Operator earths may be (in order of preference):

- An earthing switch (this includes integral earthing);
- A PED connected to a Permanent Earthing Point (PEP);
- A PED connected to an earth electrode driven to a minimum depth defined by the Electricity Entity.

Earthing of High Voltage Electrical Apparatus for the Protection of Personnel

Operator earths shall be adequate for the fault current at the location. This may be achieved by placing a maximum of two sets of PEDs at one location if necessary. If the busbar is longer than 30m operator earths shall be required in two locations.

Locations where the fault level is above the standard fault rating of PEDs are to be identified by either:

- Operating diagrams;
- Fault Level Charts at the Substations;
- Item/s in an authorised switching schedule/sheet.

Ergon Energy

Where reasonable and practicable, at least one operator earth shall be connected to a PEP before a permit may be issued. Where no PEP is available and the use of a temporary earth electrode is required for PEDs, it shall be driven to a minimum depth of 600mm, as per **SWP ST0301 – Apply and Remove Portable Earthing Devices**.

Energex

Isolated HV electrical apparatus to be accessed shall have at least one operator earth connected to a PEP. Where additional operator earthing is required (e.g. multiple HV sources of supply) the use of a temporary driven earth electrode may be used for operator earthing, as per **WP9607 - Test to prove de-energised and earth (OH Mains and Apparatus)**.

6.2. Working Earths

Working earths are placed and removed under the co-ordination of the Recipient in accordance with [Section 8. Assessing Working Earth Requirements](#) to safely discharge induced or residual voltage and limit the rise in potential difference and at the work area.

Working earths do **NOT** have a DNOB attached. **This is the prime, visible, distinction between an operator earth and a working earth.**

For access to overhead systems, if operator earths are visible from the work site and continuity can be confirmed and their integrity can be controlled and maintained, they may provide adequate protection for the work area in regards to safely discharging induced or residual voltages and limiting the rise in potential at the work area, further application of working earths may not be required.

The current-carrying capacity of a working earth and approved bridging leads used for the purposes of creating or maintaining earth continuity shall be adequate to discharge stored or induced charge and to limit rise in potential difference at the work area.

The Recipient shall co-ordinate the placement and removal of working earths. Only the Recipient or an Individual of Work Group (IWG/IOW) under the direction of the Recipient may place or remove working earths.

The placement and removal of working earths shall be recorded on the AP/TP in the working earth schedule.

Earthing of High Voltage Electrical Apparatus for the Protection of Personnel

When stringing overhead conductors near energised HV conductors, rolling earths or PEDs shall be used as per SWPs.

Where reasonable and practicable, the earth tail of PEDs shall be connected to a PEP. Where the use of a temporary driven earth electrode is required, it shall be installed as per:

Ergon Energy: SWP ST0301 – Apply and Remove Portable Earthing Devices.

Energex: WP9607 – Test to prove de-energised and earth (OH Mains and Apparatus).

6.3. Hazards & Risks Due to Induced Voltages and Currents

Induced voltages and currents may be lethal. Voltages and currents may be induced in conductors due to electromagnetic or electrostatic action. Both may be present and shall be considered when working on or near Electrical Apparatus.

Induced voltages and currents may not be limited to, or produced by the particular part of the network being worked on, but may come from other external sources (e.g. other HV lines or electrified rail networks, RF band). These may not be obvious as they may not be in the immediate vicinity of the conductors being worked on. Connection of mobile plant to an earthing point when being used adjacent to energised HV conductors shall also be considered.

Control measures shall be implemented for the management of induced voltage and current risks in accordance with [Section 8. Assessing Working Earth Requirements](#) and [Section 10. Assessing Non-Commissioned & Decommissioned Earthing Requirements](#).

If earthing continuity is not maintained in these situations persons may be exposed to lethal voltages and currents.

Earthing of High Voltage Electrical Apparatus for the Protection of Personnel

6.3.1. Electromagnetic Induction

A voltage will be induced into a conductor situated within the magnetic field of another conductor carrying current. The magnitude of the induced voltage will be directly proportional to the degree of magnetic coupling plus the length of, and the load current in, the parallel conductor.

If the ends of the induced conductor are connected via other conductors or the earth to form a loop, then current will flow in the loop. The magnitude of this circulating current will be dependent on the induced voltage and the impedance of the loop.

Electromagnetically induced voltages may occur where a conductor or cable:

- Crosses an energised conductor or cable,
- Runs parallel with an energised conductor or cable,
- Is on the same structure or in the same trench as an energised conductor or cable.

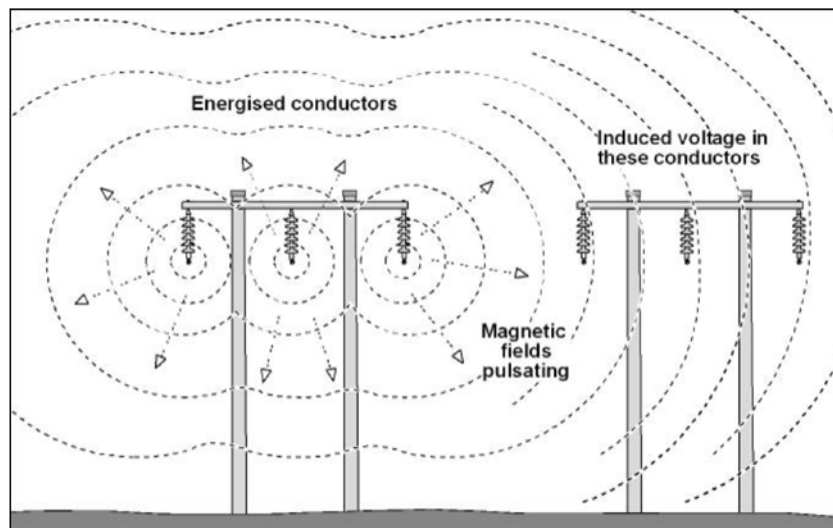

Earthing of High Voltage Electrical Apparatus for the Protection of Personnel

6.3.2. Electrostatic Induction

A natural electric field always exists above the Earth's surface. Wind blowing over conductors or cloud movement may cause a statically induced voltage on metallic objects or overhead equipment that may be a hazard to workers.

If the ends of the statically induced conductor are connected via other conductors or the earth to form a loop, then current will flow in the loop. The magnitude of this circulating current will be dependent on the induced voltage and the impedance of the loop.

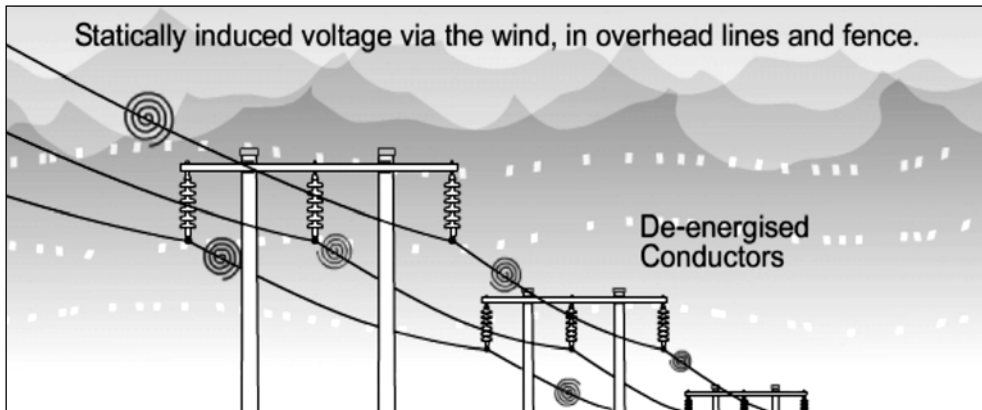

Earthing of High Voltage Electrical Apparatus for the Protection of Personnel

7. EARTHING REQUIREMENTS FOR SPECIFIC HIGH VOLTAGE ELECTRICAL APPARATUS

The following section includes the minimum operator earth requirements for specific electrical apparatus and typical isolation and access scenarios represented in diagrams.

Whilst the examples provided cover typical scenarios, there will be other specific scenarios that will arise. Each of these shall require analysis and assessment to clearly identify electrical hazards and ensure adequate operator earths are applied to ensure HV electrical apparatus in the area where a work area is to be established is earthed prior to the issue of an AP/TP.

Working earths are placed and removed under the co-ordination of the Recipient in accordance with [Section 8. Assessing Working Earth Requirements](#) to safely discharge induced or residual voltage and limit the rise in potential difference and at the work area.

7.1. Legend of Symbols

The following symbols are used in this document:

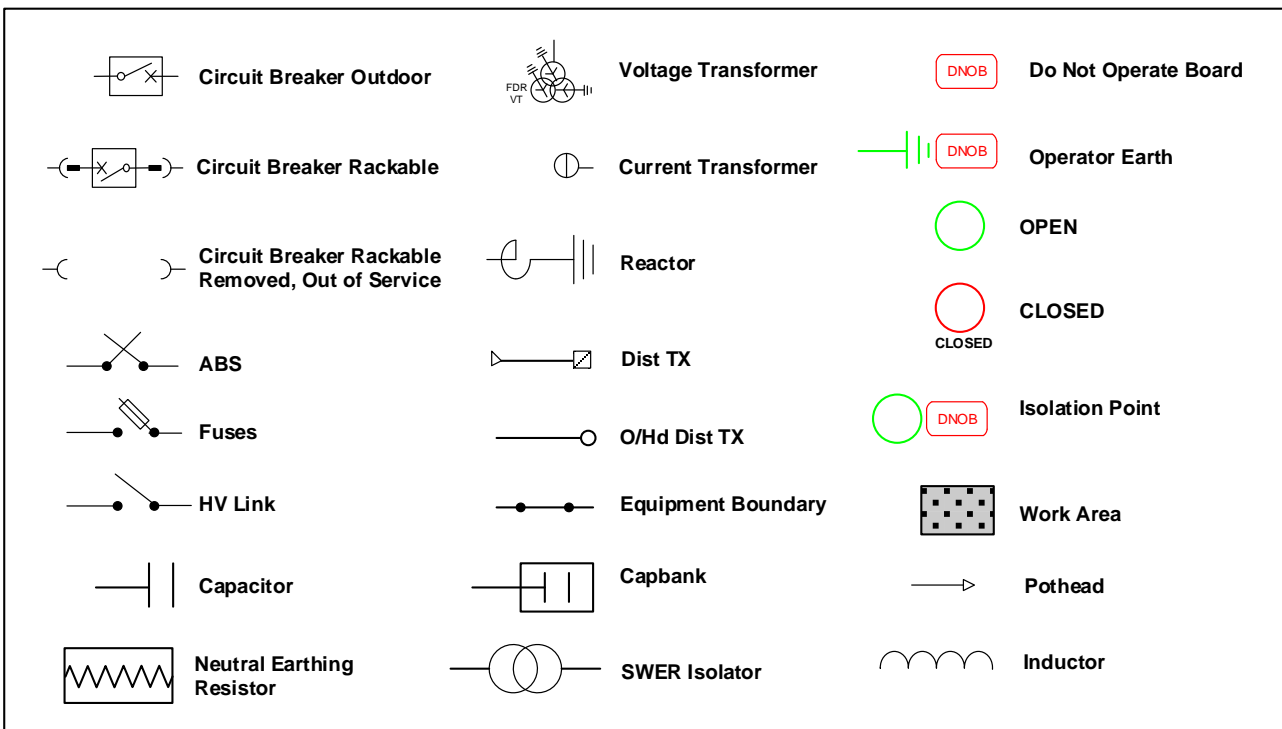

Earthing of High Voltage Electrical Apparatus for the Protection of Personnel

7.2. Earthing of Transmission Lines/Sub Transmission Lines

When placing operator earths for access to a transmission line, or access to equipment attached to a transmission line, (line isolator, line VT, etc.), an operator earth shall be placed between the work area and any HV Source of supply.

Energex - Where reasonable and practicable, one Operator Earth must be placed at a Substation.

7.2.1. Example 1 – Transmission Lines/Sub Transmission Lines Connecting Two Substations

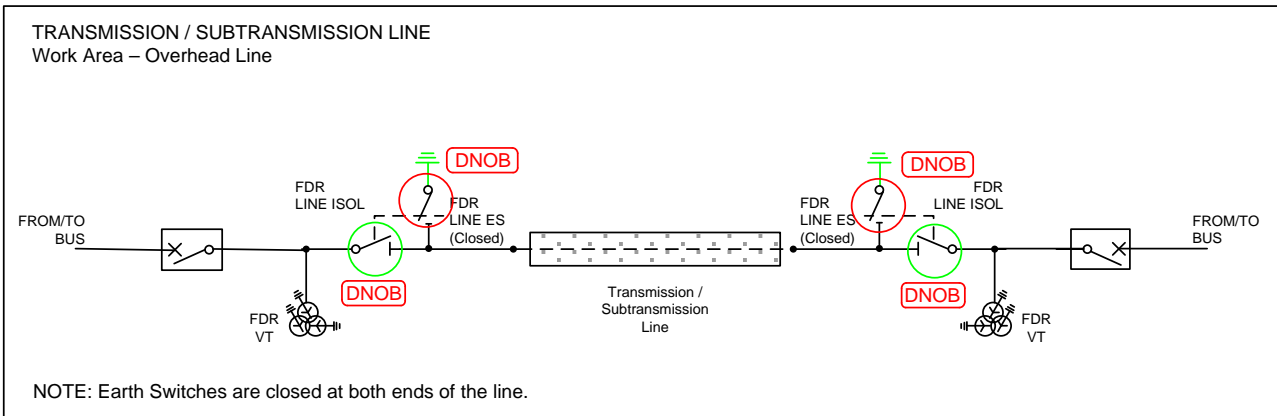

7.2.2. Example 2 – Transmission Lines/Sub Transmission Lines Connecting Two Substations – Extended Isolation

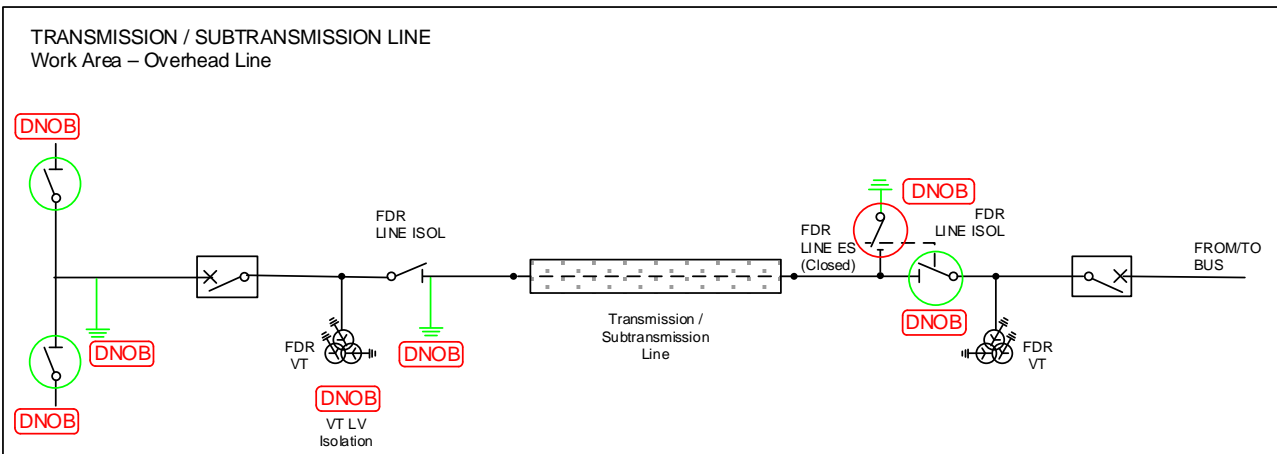

In example 2 above, isolation is extended, as the line isolator is not able to be used as an isolation point in this instance.

Earthing of High Voltage Electrical Apparatus for the Protection of Personnel

7.2.3. Example 3 –Transmission Lines/Sub Transmission Lines - Radial/Transformer Ended Feeder - Ergon Energy Only

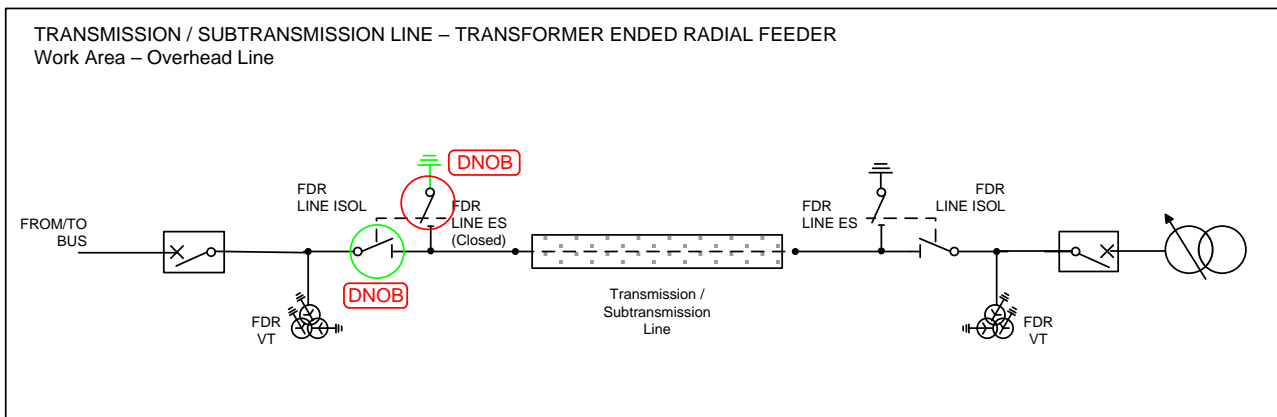

*In example 3 above, isolation and earthing is not required at the remote end of a transformer ended feeder **where there are no possible sources of back feed.***

7.3. Earthing of Transmission / Sub Transmission Lines between Interconnected Substations

When placing operator earths for access to sub transmission lines between interconnected substations, or access to attached HV electrical apparatus (line isolator, line VT, etc.), operator earths shall be placed between the work area and any HV Source of supply.

Ergon Energy – See 7.3.1.

Where there are ties to other feeders or teed in substations it may be acceptable to place PEDs on the work area side of the tee off.

Earthing of High Voltage Electrical Apparatus for the Protection of Personnel

7.3.1. Example 1 – Transmission/Sub Transmission Lines connecting Two Substations With Interconnecting Tie – Ergon Energy Only

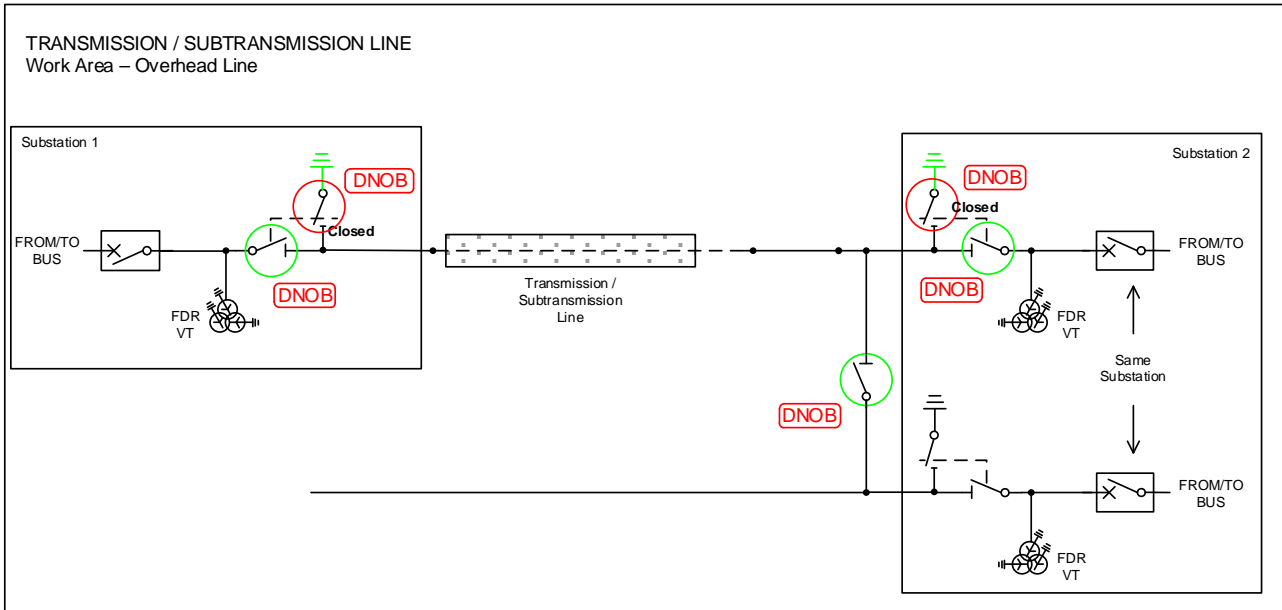

In example 1 above, the interconnecting tie between the two feeders is located just outside the fence of Substation 2. Due to the tie's proximity to Substation 2 and the reliability of Transmission/Sub Transmission protection schemes, the earth switch provides adequate operator earthing for work on the feeder.

7.3.2. Example 2 – Transmission/Sub Transmission Lines Connecting Two Substations With An Interconnecting Tie

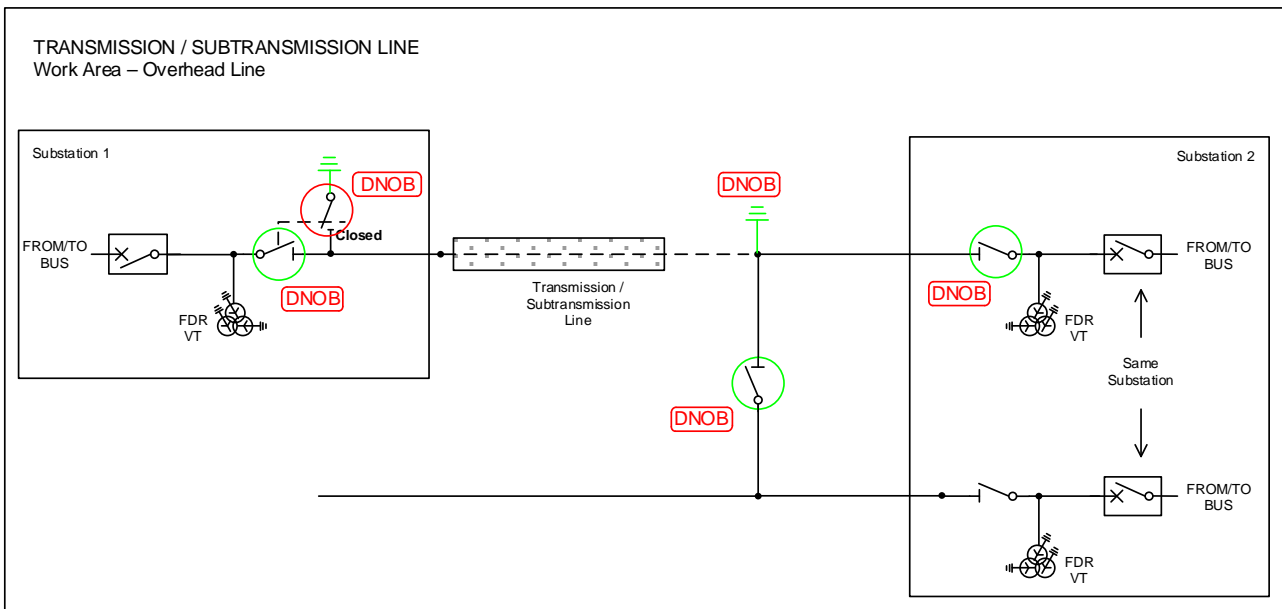

In example 2 above, the interconnecting tie is located out on the feeder and is not in proximity to substation 2. For this reason PEDs have been applied on the work area side of the tee off to provide adequate Operator Earthing.

Earthing of High Voltage Electrical Apparatus for the Protection of Personnel

7.3.3. Example 3 – Transmission Lines/Sub Transmission Lines Connecting Two Substations With An Interconnected Transformer Ended Feeder

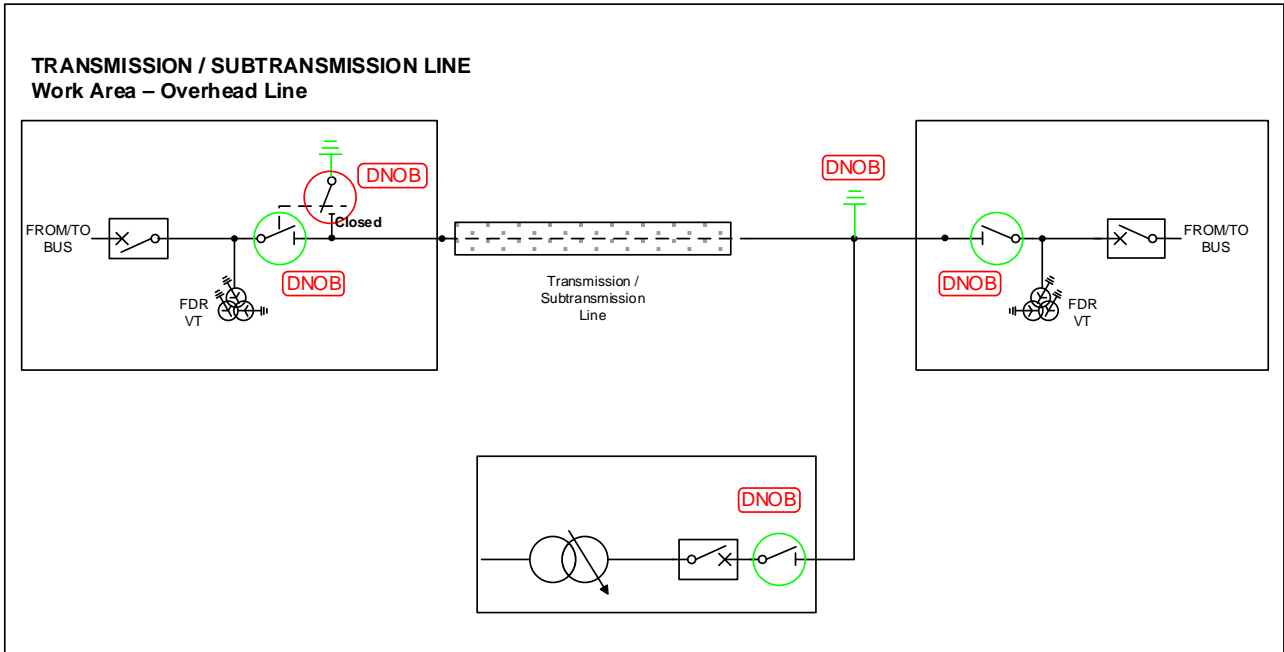

Earthing of High Voltage Electrical Apparatus for the Protection of Personnel

7.4. Earthing of Zone Substation Apparatus and Transmission/Sub Transmission Lines

Operator earths are placed so that earthed apparatus exists between each isolation point and the work area on the HV apparatus prior to issue of AP/TP and to cause the work areas to be de-energised in the event of inadvertent re-energisation.

7.4.1. Example 1 – Substation Feeder Bay and Transmission Lines/Sub Transmission Lines Connecting Two Substations – Common Isolation

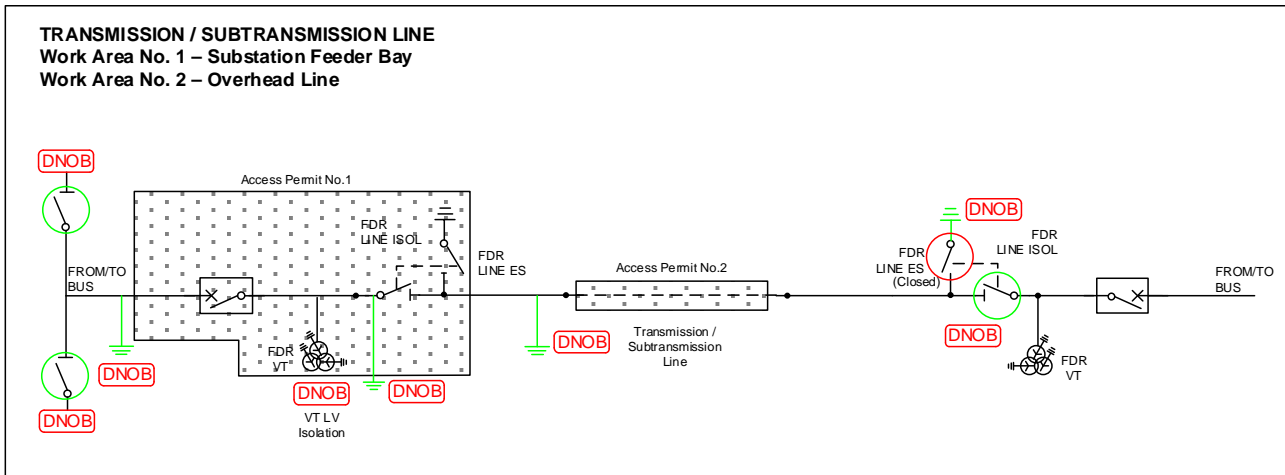

In example 1 above, two separate work areas exist:

- Access Permit No.1 the CB, the VTs, the FDR LINE Isolator and FDR LINE Earth Switch located in the Substation Feeder Bay are to be maintained;
- Access Permit No.2 on the Transmission/Sub Transmission line between Zone Substations.

The FDR LINE Earth Switch at the remote end of the Transmission/Sub transmission overhead line is closed as an operator earth.

PEDs are placed at the end of the Transmission Line/Sub transmission line between the Access Permit No.1/2 work areas and also on the CB side of the line isolator. This ensures that continuity of operator earthing is maintained for each separate work area in the event that open points are created by the individual work tasks of the separate work groups.

Earthing of High Voltage Electrical Apparatus for the Protection of Personnel

7.4.2. Example 2 – Substation Feeder Bay and Transmission Lines/Sub Transmission Lines Connecting Two Substations – Separate Isolation

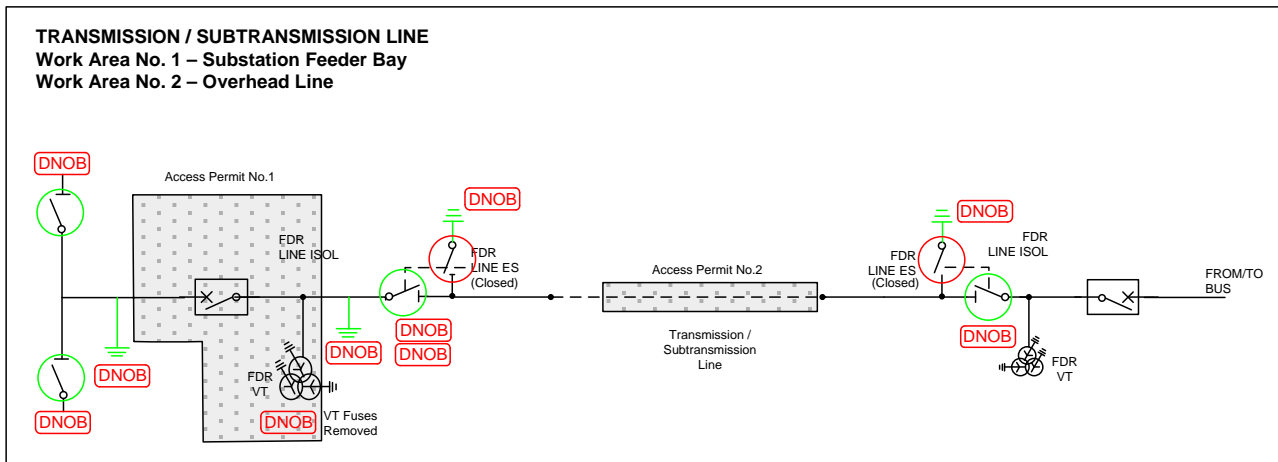

In example 2 above, two separate work areas exist with a common isolation point:

- Access Permit No.1 to maintain the FDR CB within the Zone Substation;
- Access Permit No.2 on the Transmission/Sub Transmission line between Zone Substations.

Each Work Area has its own isolation points and operator earths. This provides greater flexibility, in that operator earths may be removed under an AP/TP in each work area to suit the progress of work without affecting the other work group.

Earthing of High Voltage Electrical Apparatus for the Protection of Personnel

7.4.3. Example 3 – Zone Substation Dual Bus

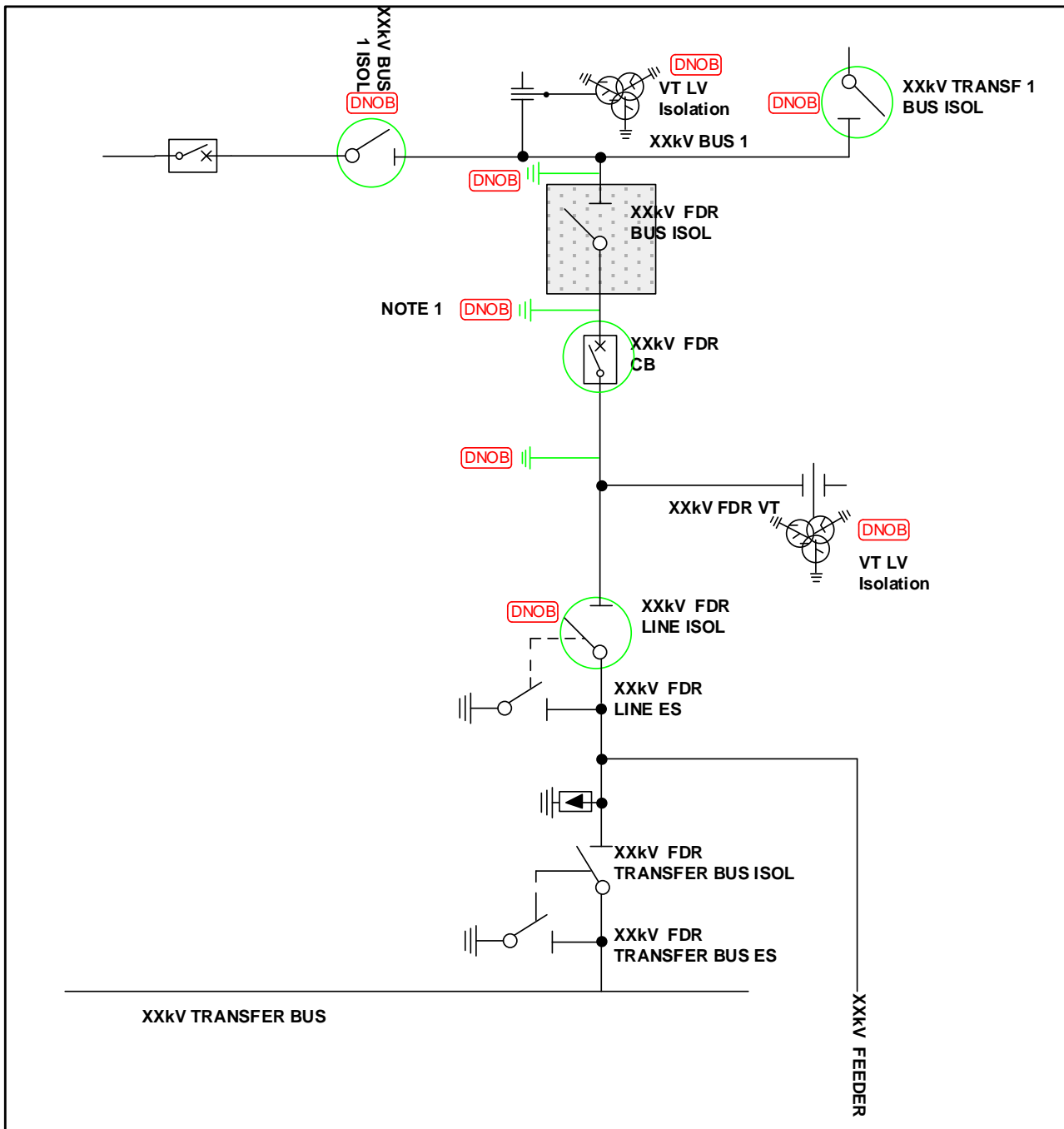

Note 1: In example 3 above, the FDR CB adjacent to the work area is unable to be made inoperable; therefore an operator earth is required on the work area side of the CB.

Earthing of High Voltage Electrical Apparatus for the Protection of Personnel

7.4.4. Example 4 – Zone Substation Dual Bus

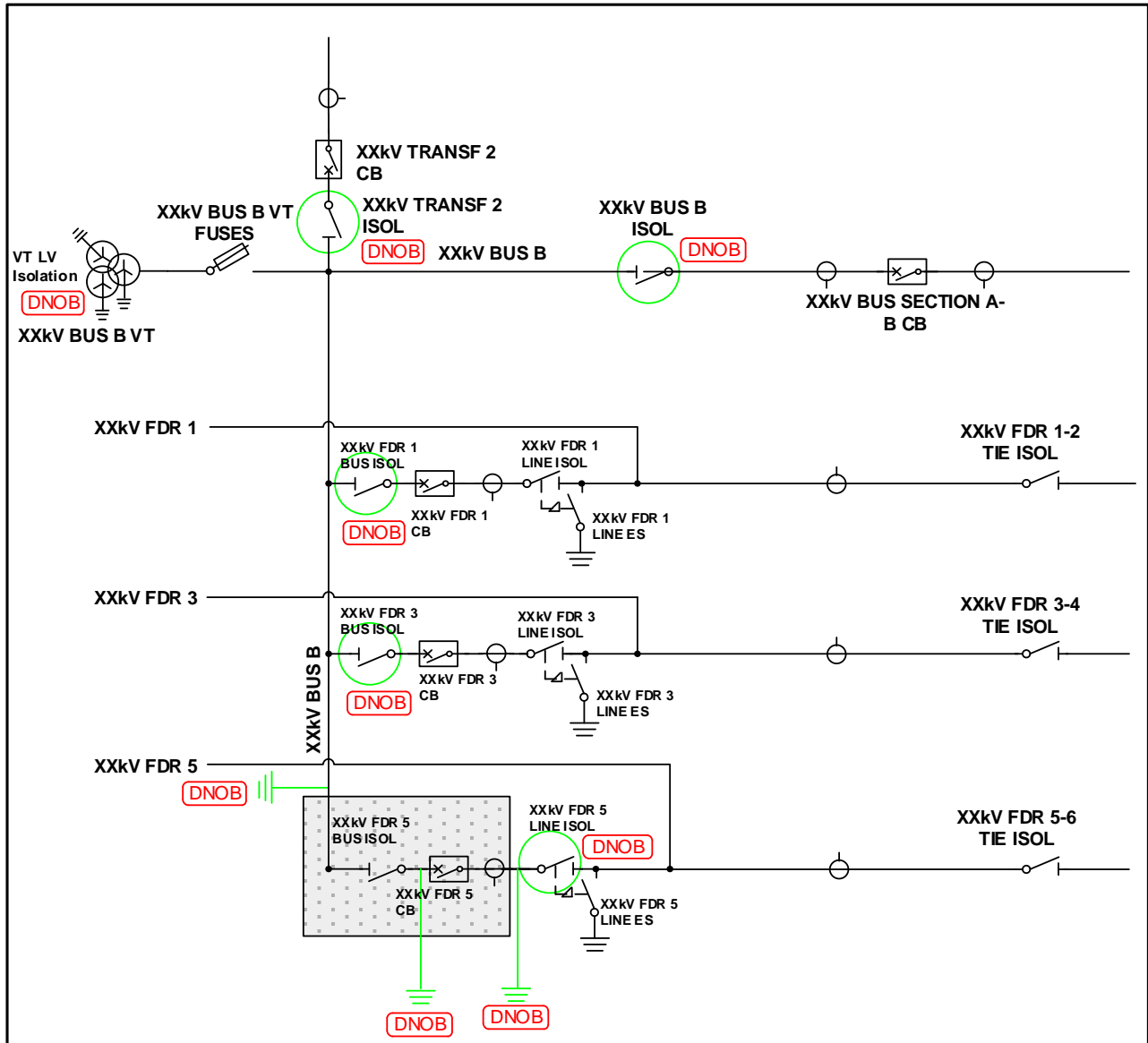

Earthing of High Voltage Electrical Apparatus for the Protection of Personnel

7.4.5. Example 5 – Zone Substation Transformer and Transformer CB

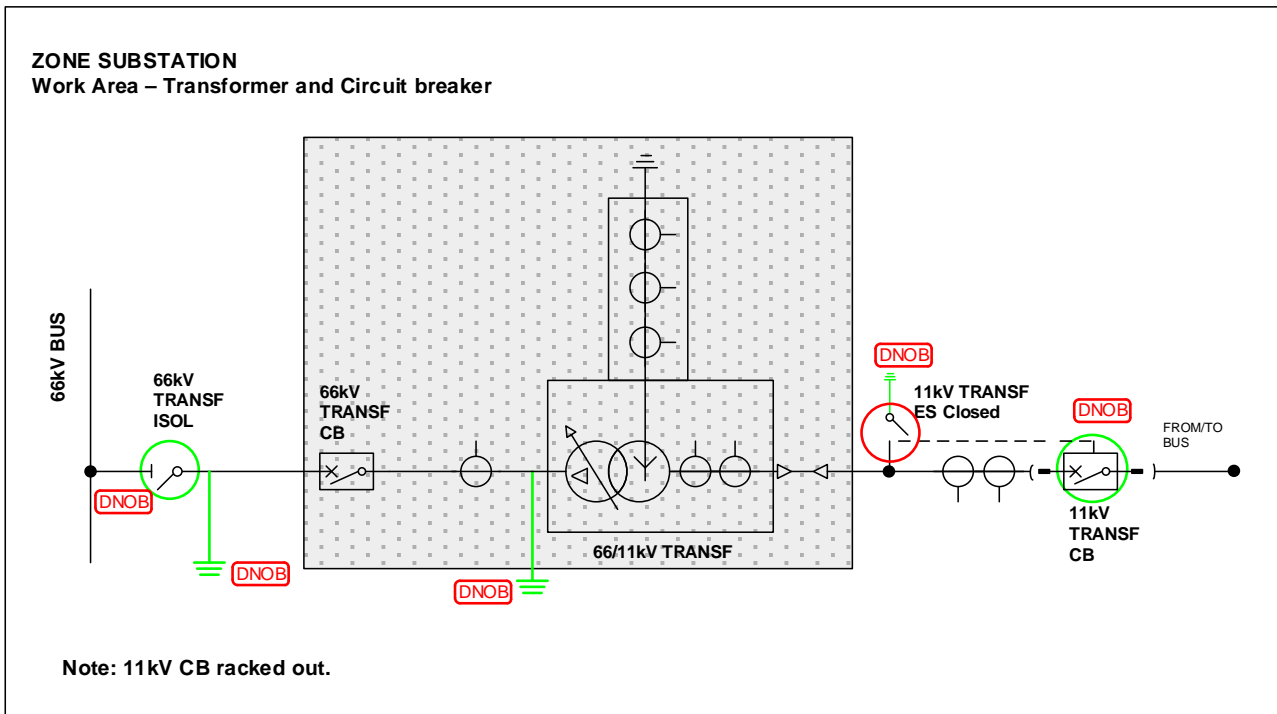

In example 5 above, an additional operator earth is required between the 66 kV CB and Transformer to ensure all electrical apparatus in the work area is earthed prior to the issue of an AP/TP.

7.4.6. Example 6 – Zone Substation Transformer

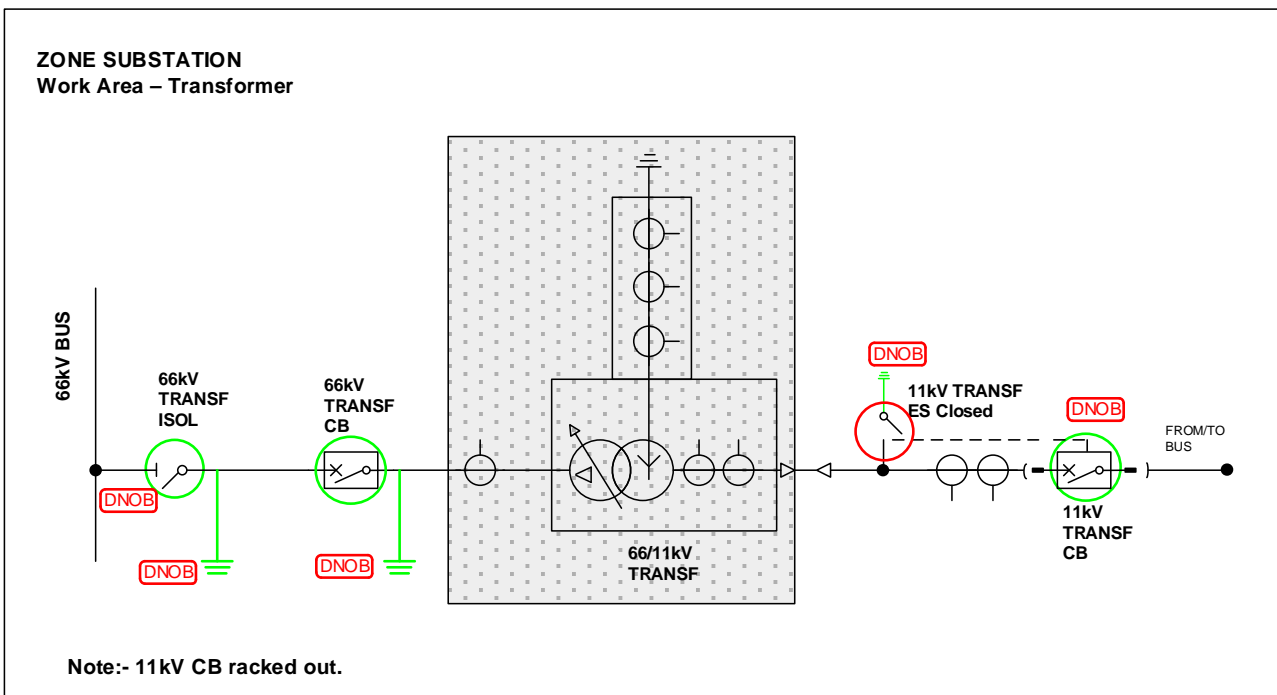

Earthing of High Voltage Electrical Apparatus for the Protection of Personnel

7.4.7. Example 7 – Zone Substation Transformer

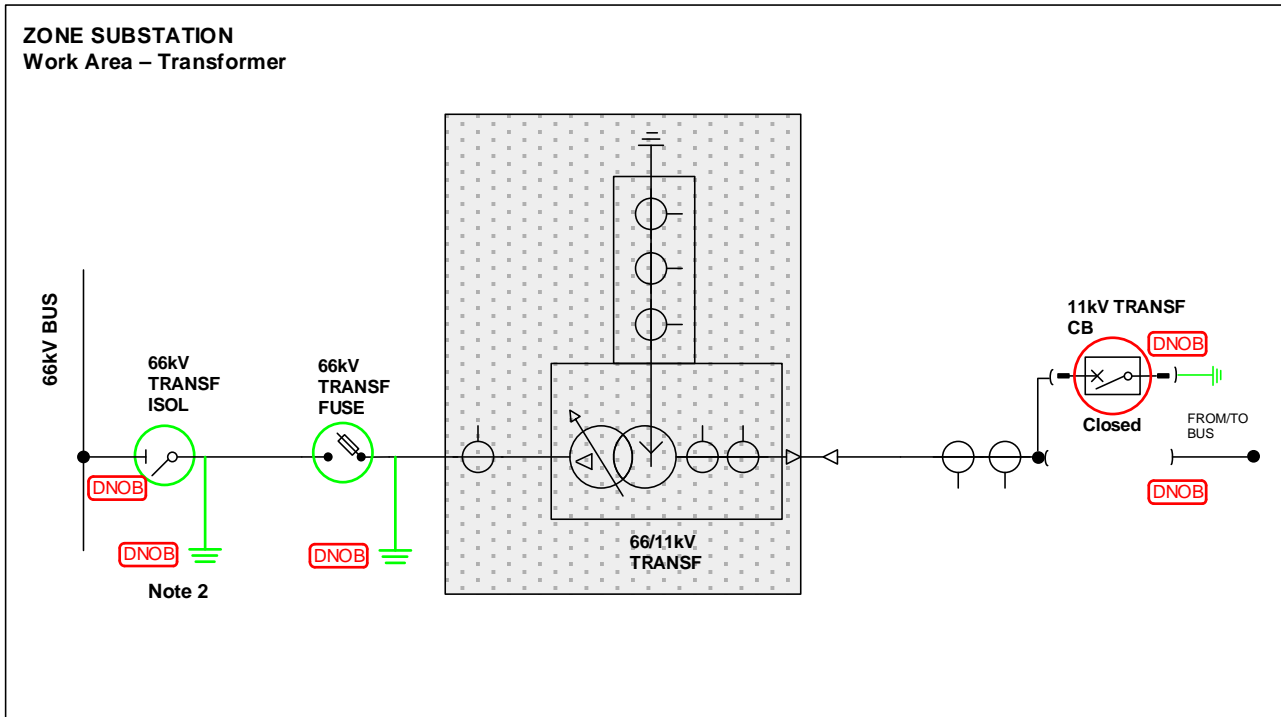

Note 1: In example 7 above, the withdrawable 11kV CB is placed into the circuit earth position, closed and made inoperable to provide an operator earth for access to the transformer. The bus shutters shall be locked with a DNOB attached. This is an example of integral earthing. Where specific switchgear design does not allow locking and attachment of a DNOB to shutters, place in a prominent position such that the device cannot be operated without encountering the DNOB.

Note 2: If the 66kV transformer fuse cannot be opened safely or used as an isolation point. The transformer isolator will be required as an isolation point and an additional Operator Earth is required between the Isolator and the Fuses.

Earthing of High Voltage Electrical Apparatus for the Protection of Personnel

7.5. Earthing of HV Metal Clad Switchgear and Busbars

Where CBs, local Substation Supply Transformers and VTs may be racked out:

- Only one operator earth is necessary to access a section of HV metal clad busbar provided;
 - All CBs/switchgear, local Substation Supply Transformers and VTs have been racked out, and;
 - All busbars shutters not used for earthing purposes have been closed, locked and a DNOB attached. Where specific switchgear design does not allow locking and attachment of a DNOB to shutters, place in a prominent position such that the device cannot be operated without encountering the DNOB.

For switchgear that has integral earthing facility, the preferred method of applying the earth is by racking the circuit breaker into the circuit earth position, closing and making inoperable (Integral). However, for some brands of CB/switchgear this is not possible and the earthing devices as supplied by manufacturer shall be used.

NOTE: *If using a CB in the closed position to earth HV Electrical Apparatus, the CB shall be made inoperable and it must be listed as a Safety Precaution in the switching schedule/sheet and AP/TP.*

Where there is duplicate (double) busbar metal clad HV switchgear, the 'live' busbar shutters are to be closed/made inoperable and a DNOB attached. The bus requiring access may then be tested to prove de-energised and earthed.

Care must be taken to connect the earth tail of PEDs to the correct earthing terminal – substation earth. Connection of the earth to the switchgear frame may lead to inadvertent tripping of the busbar/frame leakage protection. When work is to be performed on metal clad busbars and the CBs, Local Station Supplies or VTs connected to the busbar are not racked out, and then all circuits connected to such busbar shall be separately isolated and earthed.

7.6. Earthing of Exposed HV Outdoor Busbars

Where isolation points are adjacent switches on a common substation busbar, and the work area is on the teed off busbar (e.g. feeder teed off a ring bus), only one operator earth as a minimum is required between those isolation points.

7.7. Earthing of HV Transformers and Regulators

Earthing shall be placed so that earthed apparatus exists between isolation points and the work area on the transformer or regulator. Where reasonable and practicable, earths shall be visible at the work area.

If access is required to the conductors below the EDOs of distribution transformers within the work area, earths shall be applied.

Ergon Energy

If work is to be performed on the distribution transformer EDOs when the line is under access refer to Section 7.13.

Earthing of High Voltage Electrical Apparatus for the Protection of Personnel

7.8. Earthing of Audio Frequency Load Control (AFLC) Injection Equipment

Earths shall be placed between the HV isolation point and the AFLC equipment is connected to prior to entering any cubicle.

A minimum of five minutes shall be allowed before applying any earthing to allow coupling capacitor to discharge. For required duration refer to relevant operating instructions/SWP.

Where installed, the earth link contained in the coupling cell cubicle shall be tested to prove de-energised and closed. The cable side terminals of the HV capacitor shall be used as the first earthing attachment point and shall be earthed at all times. The second earth shall be placed preferably at the HV isolation transformer terminals. If there is no provision or access to the HV isolation transformer terminals then the HV capacitor terminal, tuning coil side shall be used.

7.8.1. Example 1 – Earthing of typical AFLC Coupling Cell

Example 1 below shows the general layout of the coupling cell:

1. HV capacitor terminals, cable side earthing attachment (always to be used);
2. HV isolation transformer terminals earthing attachment (preferred to be used);

When option 2 above is not available:

3. HV capacitor terminal, tuning coil side earthing attachment (only to be used when the option 2 is unavailable).

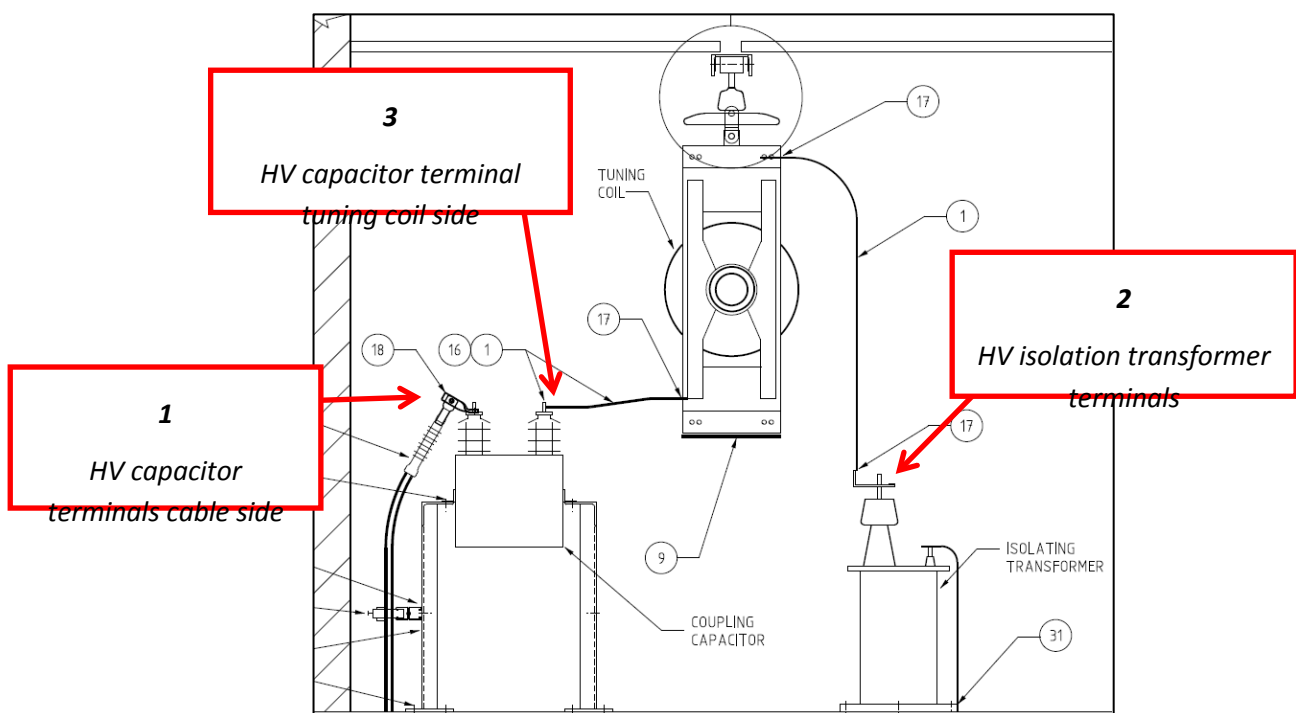

NOTE: Earth link contained in the coupling cell cubicle not installed/shown.

Earthing of High Voltage Electrical Apparatus for the Protection of Personnel

7.8.2. Example 2 – AFLC Coupling Cell Single Line Diagram

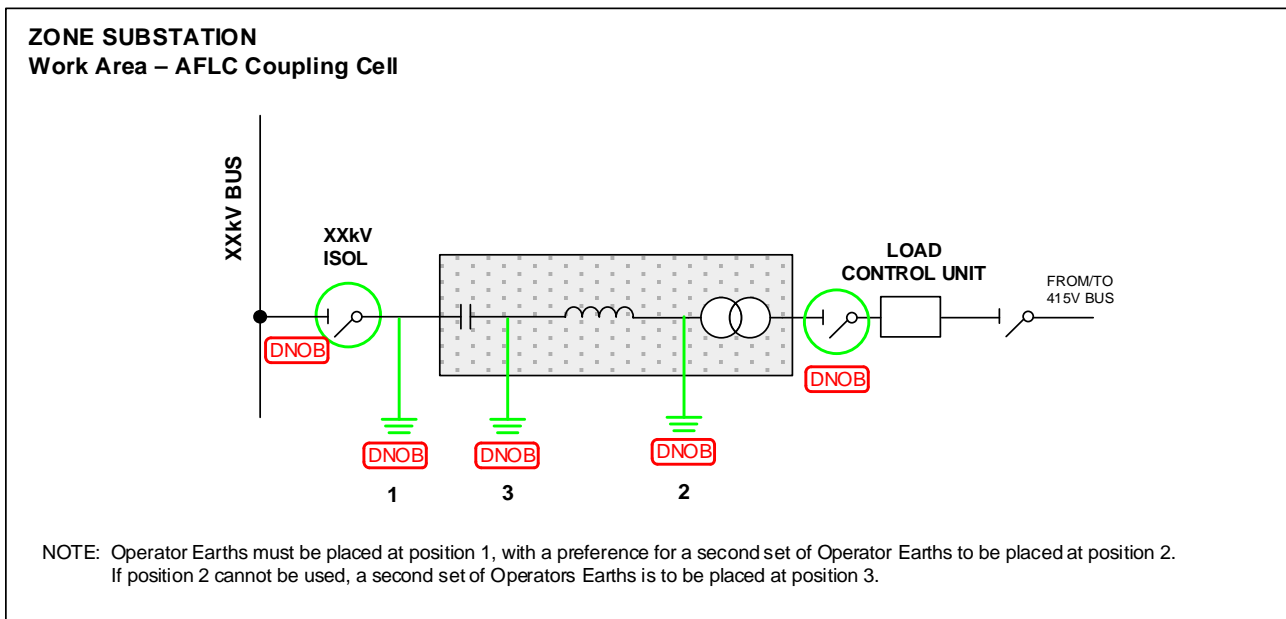

7.9. Earthing of Capacitor Banks

When work is to be performed on HV capacitor banks, earthing shall be applied on the capacitor side of the isolator/CB. A minimum of five minutes shall be allowed before applying any earthing to allow coupling capacitor to discharge. For required duration refer to relevant operating instructions/SWP.

Capacitor banks shall be discharged and approved bridging leads or working earths applied prior to any work being carried out under an AP/TP to prevent potential recharging during the duration of the work. The Recipient of the AP/TP shall record all earths placed in the working earth schedule of the relevant permit. Where dedicated discharge and earthing apparatus and/or portable working earth sets are available they shall be used.

Ensure capacitor cans remain shorted when test currents are not applied. Place a capacitor shorting bridge when capacitor cans are removed or primary busbars are disconnected.

Capacitor cans when removed must be shorted out by the use of a coloured insulated wire minimum size 2.5 mm².

Energex

All earthing for access for maintenance and corrective repair to capacitor banks shall be scoped, planned, applied for and carried out as per **WP1301 – Capacitor Bank maintenance and corrective repair**.

Ergon

Working Earths used for Capacitor banks should be a minimum of 4 mm² for durability.

Earthing of High Voltage Electrical Apparatus for the Protection of Personnel

7.9.1. Example 1 – Rackable type CB with Lockable Shutters - Integral Earth

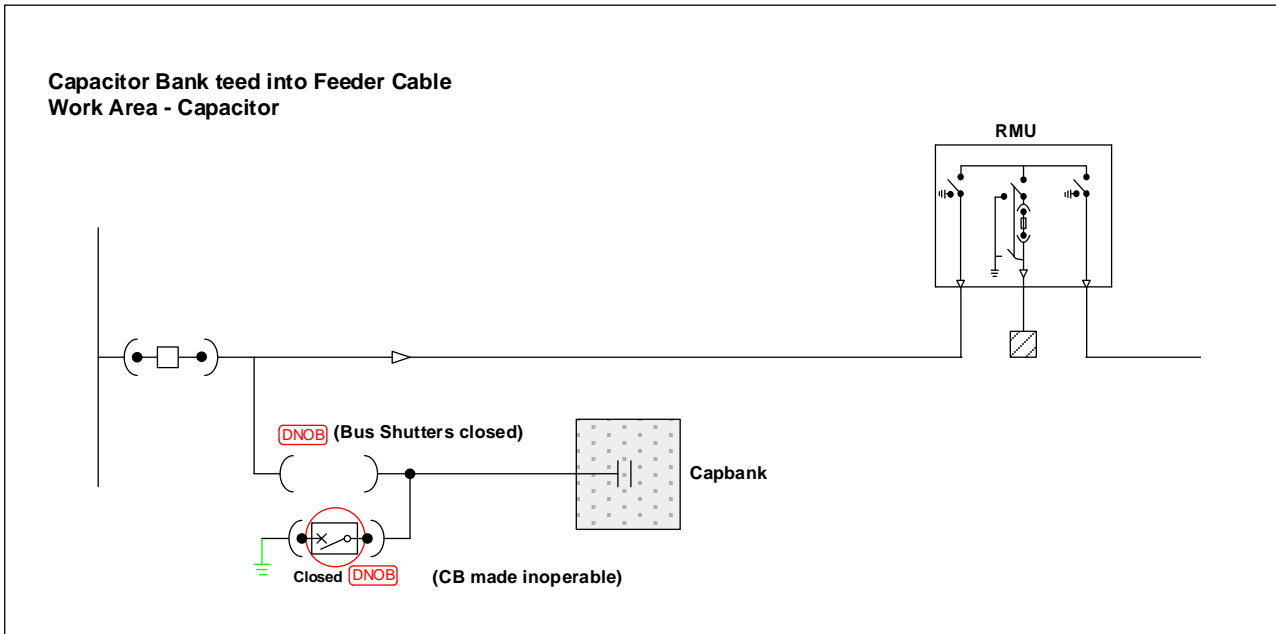

In example 1 above, the withdrawable CB is placed into the circuit earth position, closed and made inoperable to provide an operator earth for access to the capacitor bank. The bus shutters shall be locked closed with a DNOB attached.

7.9.2. Example 2 – Capacitor Bank Teed into Feeder, Interlocked Isolator/Earth Switch

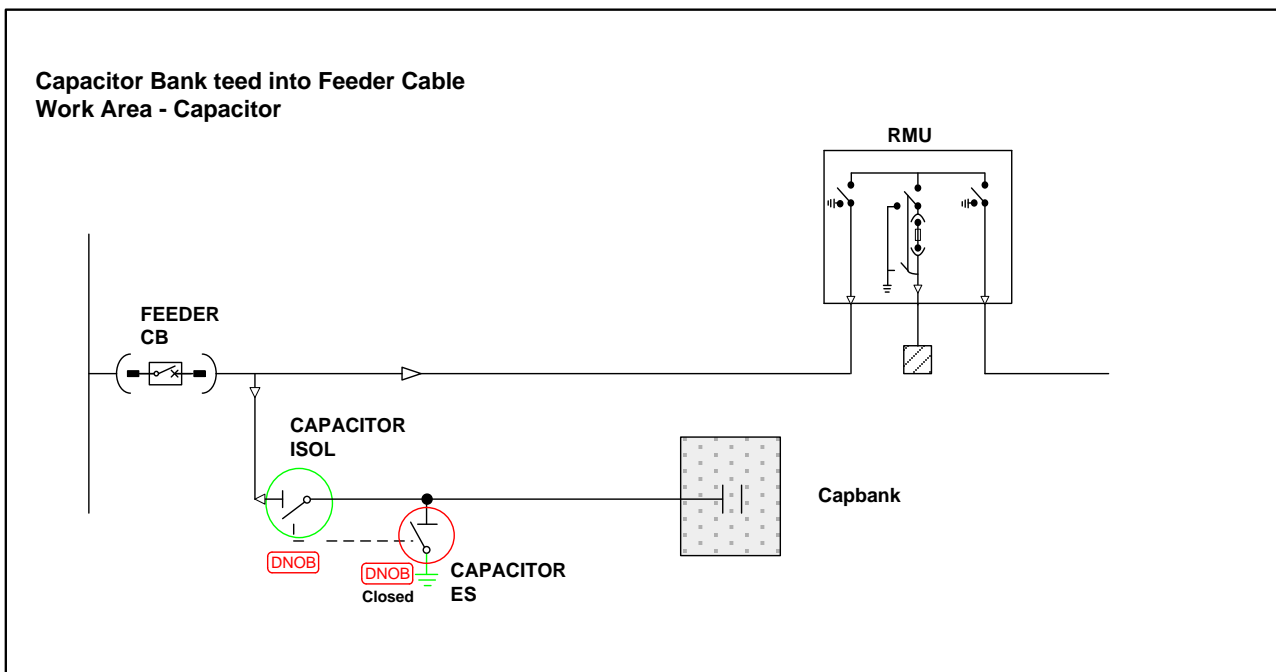

In example 2 above the capacitor earth switch is closed. The Work Area is the capacitor cans and associated equipment only i.e. NOT the capacitor isolator or cable termination.

Earthing of High Voltage Electrical Apparatus for the Protection of Personnel

7.9.3. Example 3 – Non-Rackable CB, Interlocked Isolator/Earth Switch – Ergon Energy Only

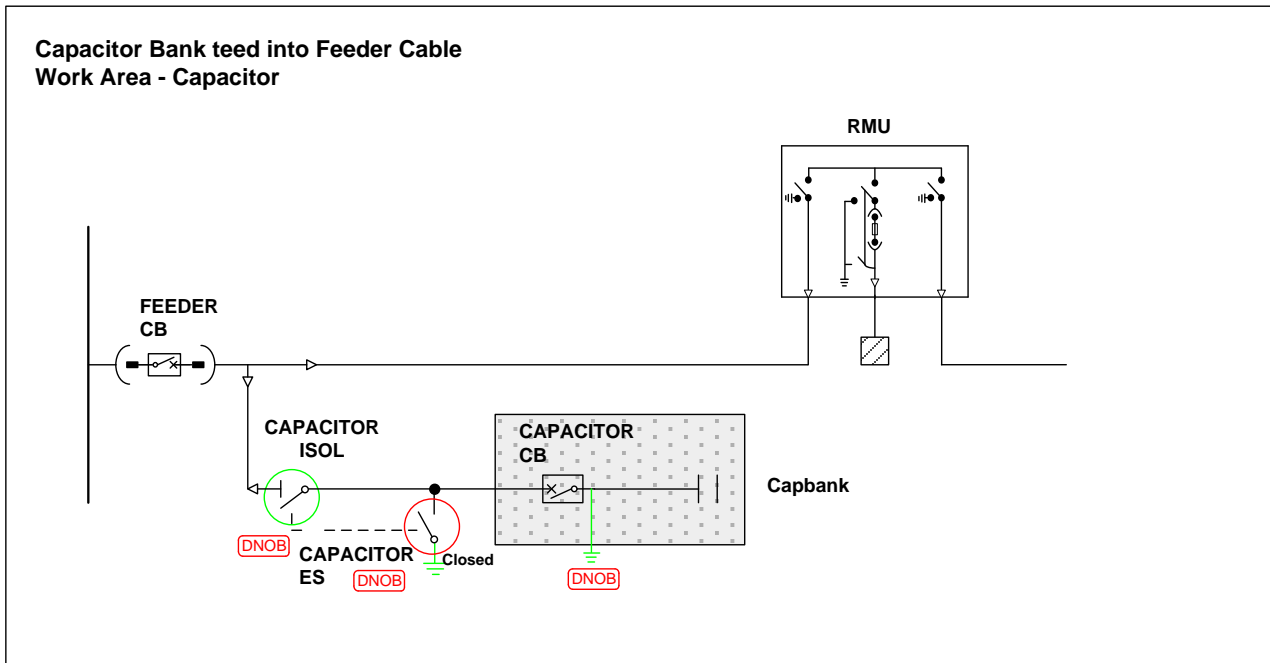

In example 3 above, the capacitor bank earthing switch is closed as an Operator Earth and an operator earth is also placed between the CB and the Capbank. This is because the capacitor bank CB cannot be made inoperable or closed and the capacitor bank may hold residual charge (particularly on equipment without discharge resistors) or may have the potential to recharge. Applying the Operator Earth between the CB and the Capacitor Cans may require a specific onsite risk assessment.

Earthing of High Voltage Electrical Apparatus for the Protection of Personnel

7.9.4. Example 4 – Capacitor Bank

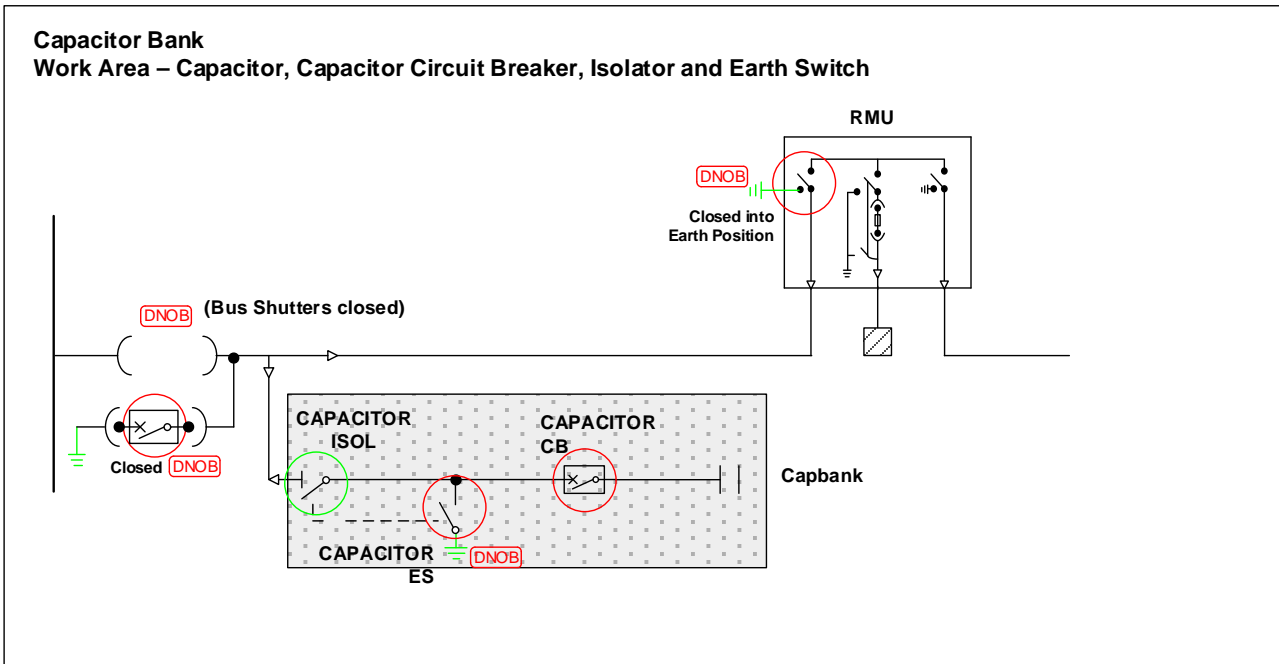

In example 4 above, if the Capacitor ES has to be maintained as part of the work to be performed, the Recipient will obtain approval for the temporary removal of operator earths in accordance Electricity Entity procedures.

7.9.5. Example 5 – Interlocked Isolator/Earth Switch

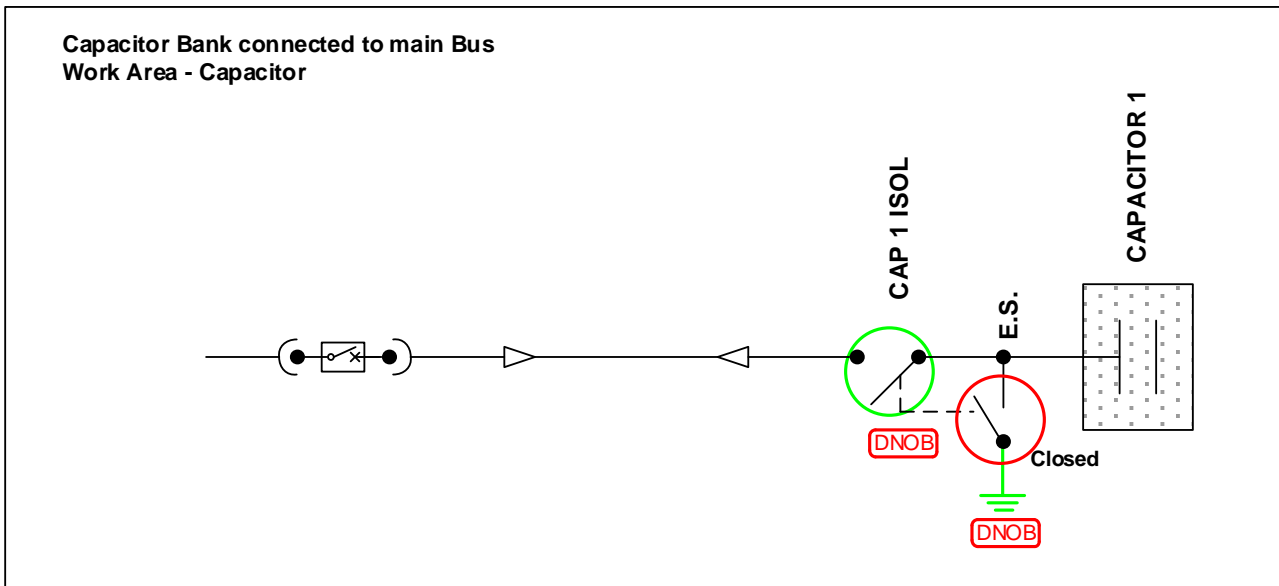

Earthing of High Voltage Electrical Apparatus for the Protection of Personnel

7.10. Earthing of Neutral Earthing Resistors (NER) / Neutral Earthing Reactors (NEX)

The following examples shall apply when working on equipment located within a Neutral Earthing Resistor (NER) cubicle. Neutral earthing resistors normally form part of the HV system. When bypassed and isolated by approved means they become part of the earthing system and exclusion zones no longer apply.

Energex

Two 70mm² Trailing Earth Leads shall be applied to the Neutral Bar of the NER to ensure minimal rise of potential occurs at the NER. It is desirable to connect the leads to the earth grid at separate points therefore spreading the distribution of potential fault currents and minimising step and touch voltages as per **WP9690 – Neutral Earthing Resistor Maintenance**.

7.10.1. Example 1 – Earthing of NERs

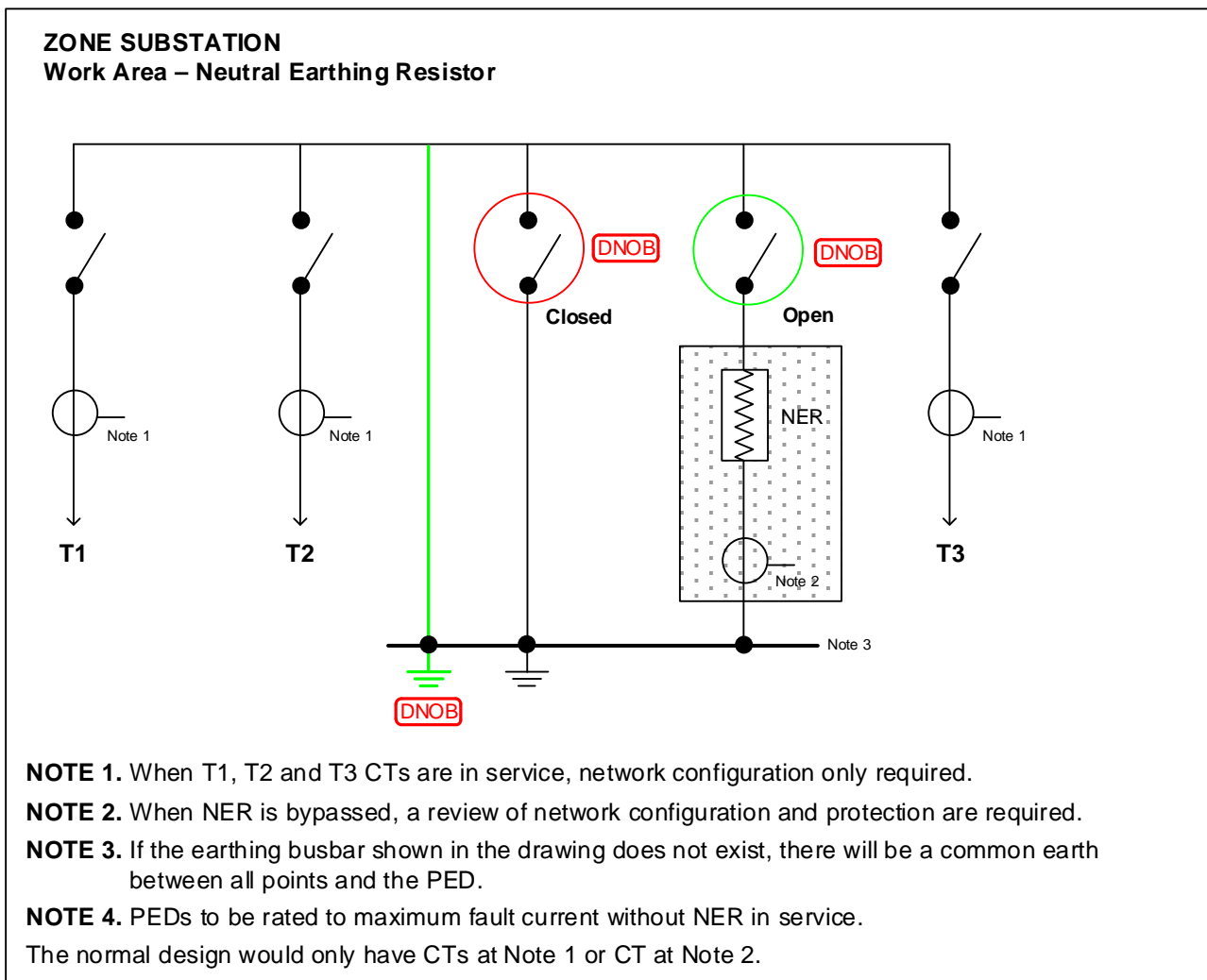

Earthing of High Voltage Electrical Apparatus for the Protection of Personnel

7.10.2. Example 2 – Earthing of NERs

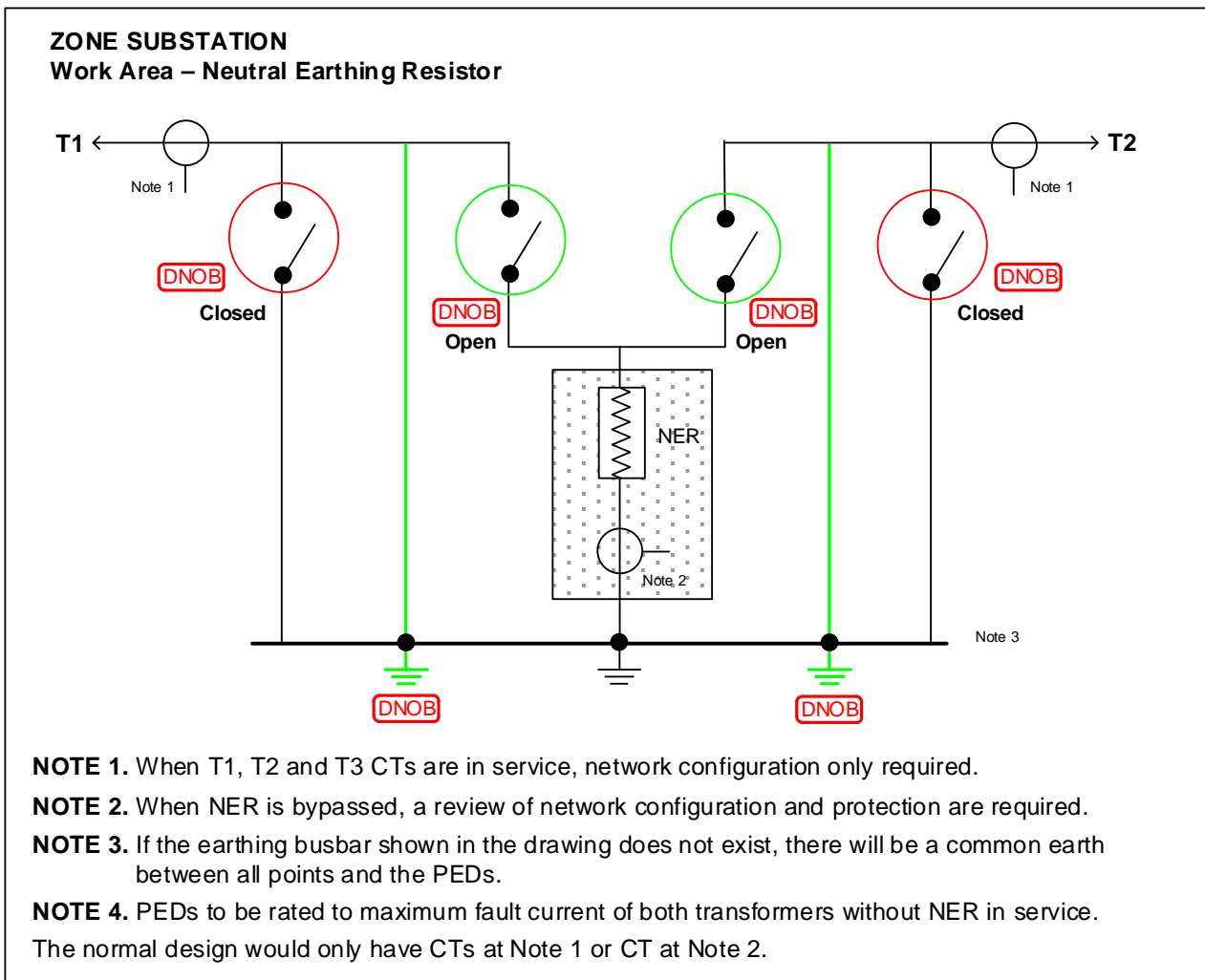

In example 2 above:

- If only Transformer 1 (T1) is in service, the T1 bypass link must be closed and earths placed between the T1 bypass link and the T1 NER isolation link as the link/s cannot be used as an Operator Earth.
- If only Transformer 2 (T2) is in service, the T2 bypass link must be closed and earths placed between the T2 bypass link and the T2 NER isolation link as the link/s cannot be used as an Operator Earth.
- If Transformer 1 (T1) and Transformer 2 (T2) are both in service, the T1 and T2 bypass links must be closed and earths placed between both the T1 and T2 bypass links and the T1 and T2 NER isolation links as the link/s cannot be used as an Operator Earth.

Earthing of High Voltage Electrical Apparatus for the Protection of Personnel

7.10.3. Example 3 – Earthing of NER and NEX

The following example shows the earthing requirements for standalone NER or NEX on a transformer.

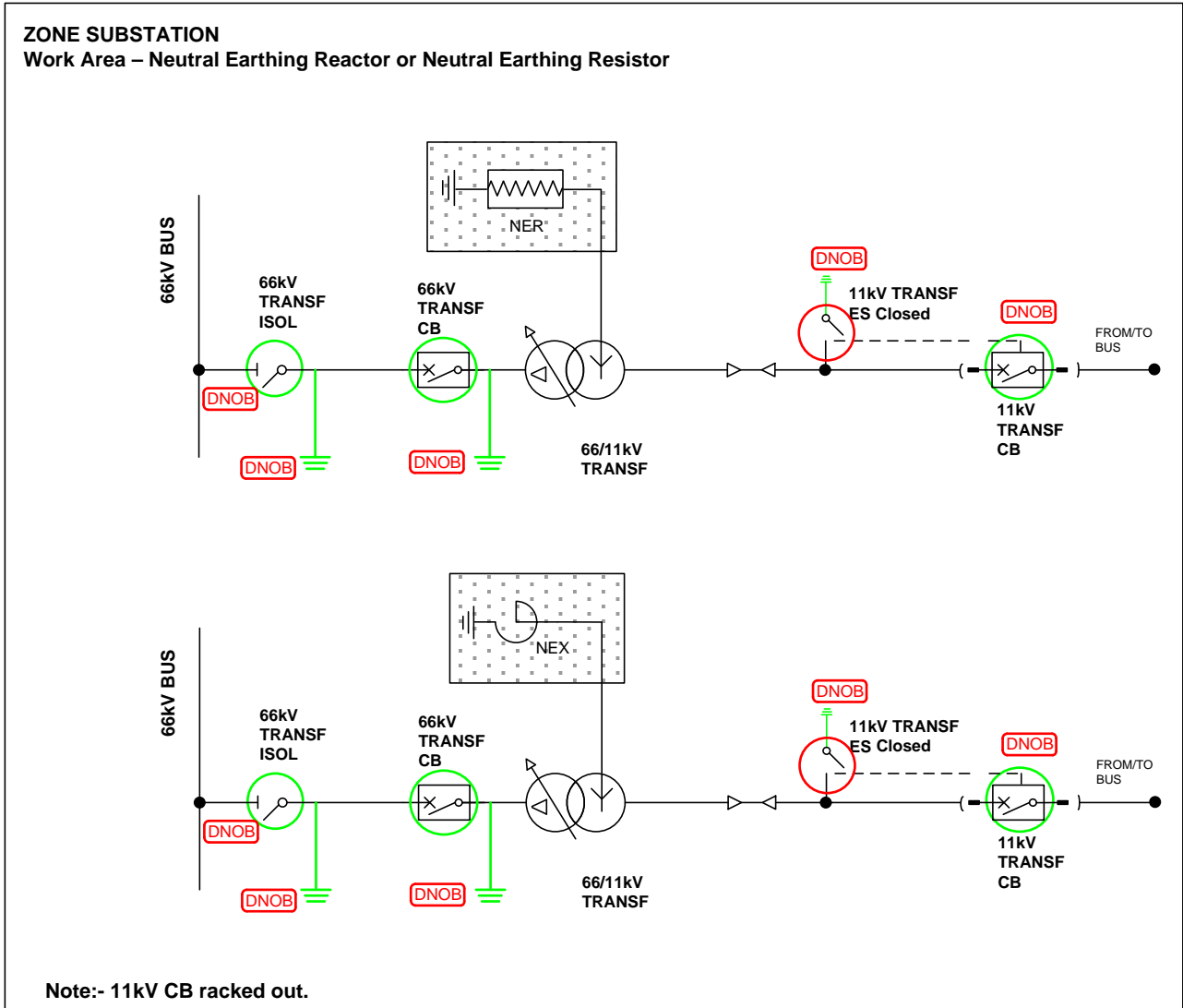

Earthing of High Voltage Electrical Apparatus for the Protection of Personnel

7.11. Earthing of HV Underground Cables

Operator earths shall be placed at HV isolation points to ensure all apparatus at the work area are earthed prior to issue of AP/TP.

When work is to be performed on HV underground cables and open points will be created in the course of the work, operator earths shall be used in preference to working earths to maintain earthing integrity.

Energex

In certain situations on the underground network, the design of the installed electrical apparatus allows only one operator earth to be applied to the HV cable(s) under an AP – Additional control measures shall be used as per **WP9450 – Positive Identification and Working on Underground High Voltage Cables**.

7.11.1. Example 1 – HV Underground Cable

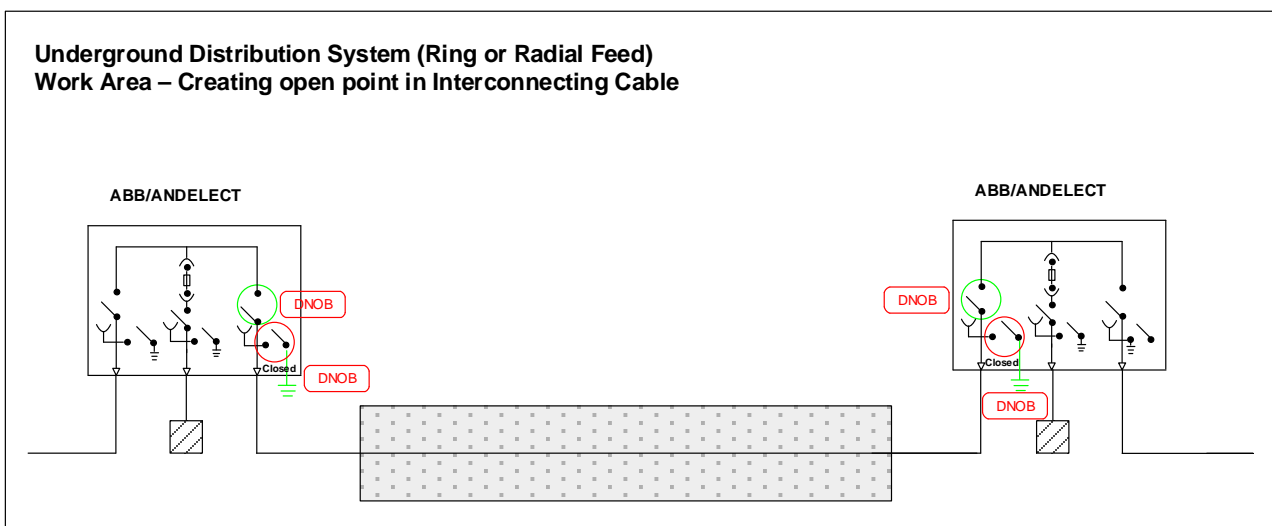

In Example 1 above, operator earths are placed at both isolation points as an open point in the apparatus under access will be created when the cable is cut / spiked to add new apparatus.

Earthing of High Voltage Electrical Apparatus for the Protection of Personnel

7.11.2. Example 2 – Working on Underground Cables connected to the Overhead Network

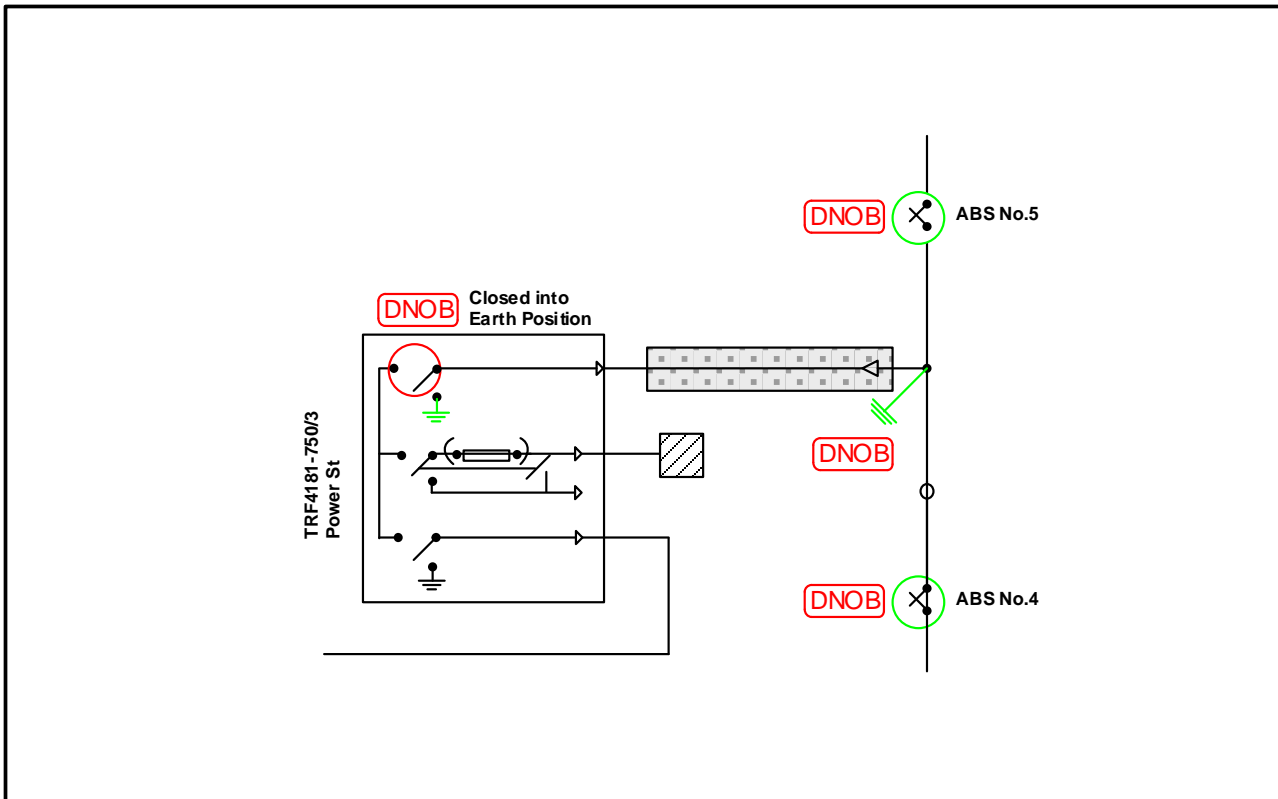

In example 2 above, access is to be given to the underground cable connected to the padmounted transformer. Operator earths are applied at earth switch of the RMU and on the overhead mains. It is sufficient to place one set of operator earths at the site where the cable is bridged to the overhead mains i.e. operator earths are not required between each isolation point and the site where the cable is bridged to the overhead mains.

Earthing of High Voltage Electrical Apparatus for the Protection of Personnel

7.12. Earthing of Ring Main Units (RMU)

Prior to access, the complete RMU(s) under maintenance/inspection shall be isolated at all remote ends, regardless of network interconnectivity. A minimum of one set of Operator Earths for each HV underground cable associated with the isolated RMU(s) shall be applied at each remote HV Isolation Point.

On any RMU to be accessed in a Work Area that has spare switches, the spare switches must be closed prior to the Operator Earths being applied to ensure all parts of the RMU are earthed prior to the issue of AP/TP.

Where multiple work groups are working on separate permits within the same isolated area, the Recipients of each permit shall consider the potential of earthing continuity being compromised by the other's work tasks when performing a risk assessment to determine working earth requirements.

Energex

It is the Recipient's responsibility to place all switches fuses on the RMU being accessed into the earth position and record in the working earth schedule of AP prior to accessing the RMU.

7.12.1. Example 1 – Earthing of a Safelink RMU in a Padmount Transformer

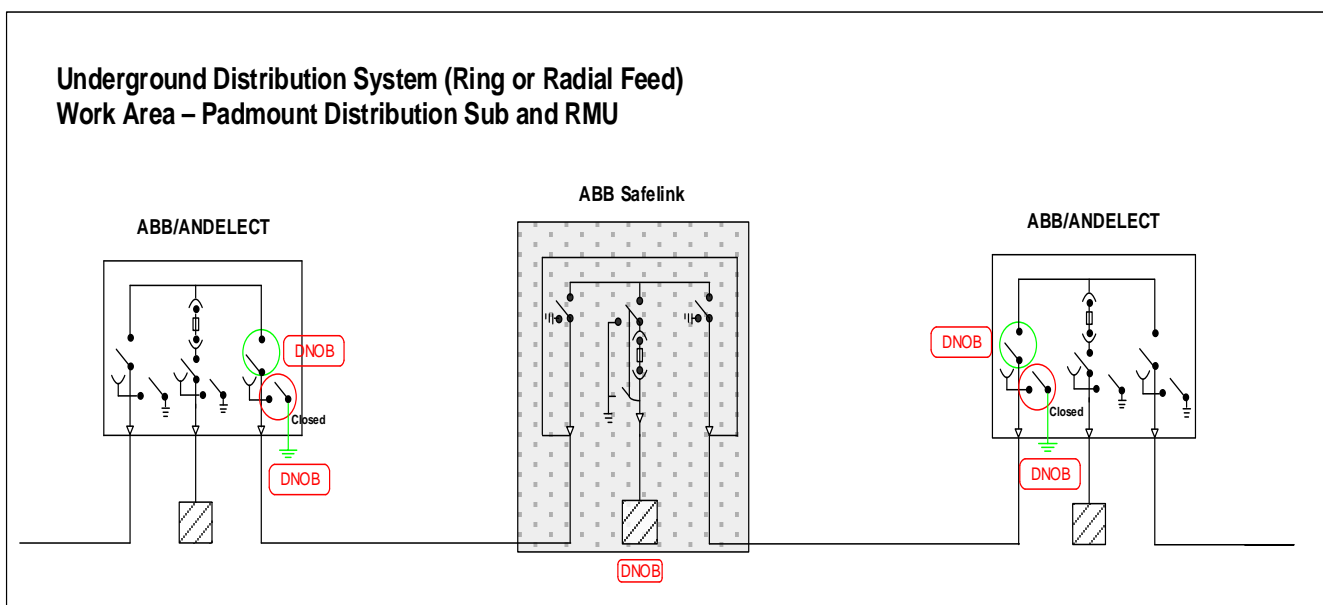

Earthing of High Voltage Electrical Apparatus for the Protection of Personnel

7.12.2. Example 2 – Earthing of Safelink & Hazemeyer RMUs in Padmount Transformers

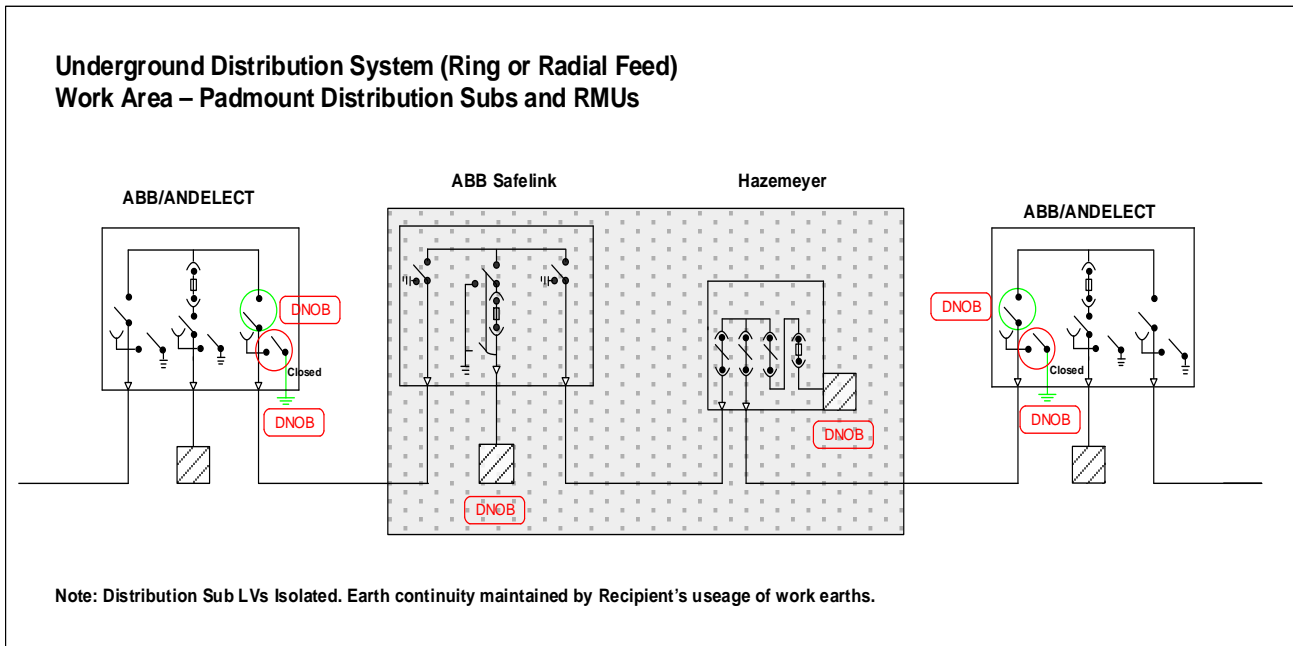

In example 2 above, operator earths are placed at both ends of the isolated area. Sequencing of the placement and removal of working earths between recipients is required in multiple work area situations to maintain earth continuity for all work groups.

In this specific example, switches that require opening for the maintenance tasks on one crew's RMU may affect the continuity of earthing for another crew's RMU and this may require coordination between Recipients of the multiple permits.

7.13. Overhead Distribution System

To access HV Aerial Bundled Conductors (ABC), earths shall be applied as close as reasonably practicable to any persons required to work on the isolated system so that where reasonable and practicable (e.g. Overhead system) the earths are within sight of such persons. Where there are multiple circuits of ABC at the work area a safe system of work shall be put in place to ensure the positive identification of the correct circuit e.g. clearly labelled/name plates on poles or similar.

Ergon Energy

Where an overhead distribution line that has been placed under access includes either reclosers, sectionalisers, line fuses or transformer EDO's that may open inadvertently, the Recipient shall maintain earthing downstream of these devices by applying Working Earths.

This is due to the large work area where the work crew may move along multiple sites and these sites may have significant distances between them. This removes the need for multiple Access Permits required to be issued and where there may be restricted communications.

If there is a separate work area on a distribution transformer on a line that is already under access, the transformer shall have its own isolation point and operator earths applied. [Refer to Section 7.7.](#)

Earthing of High Voltage Electrical Apparatus for the Protection of Personnel

7.13.1. Example 1 – Interconnected Overhead Distribution System

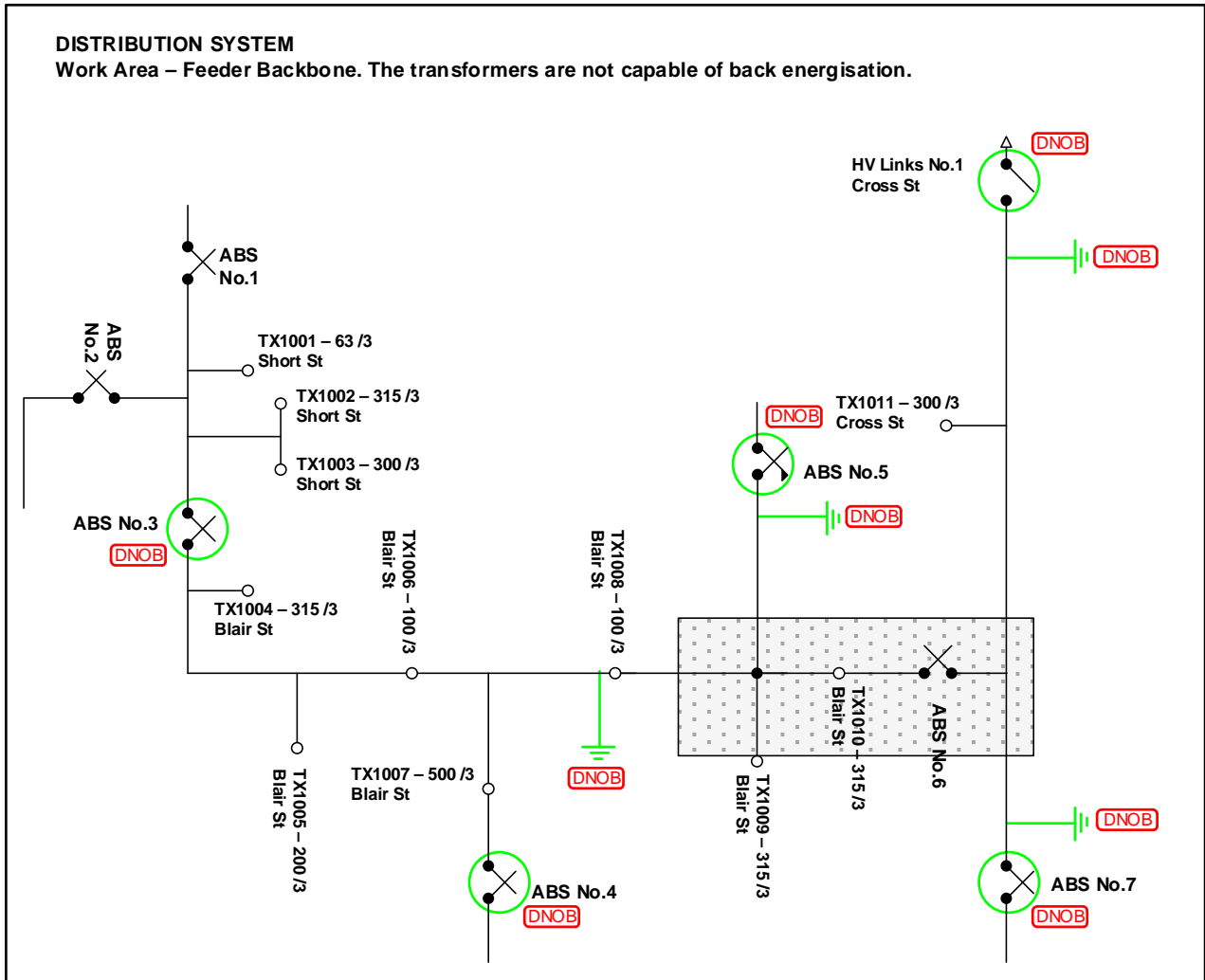

Earthing of High Voltage Electrical Apparatus for the Protection of Personnel

7.13.2. Example 3 – Interconnected Overhead Distribution System – Two Work Areas

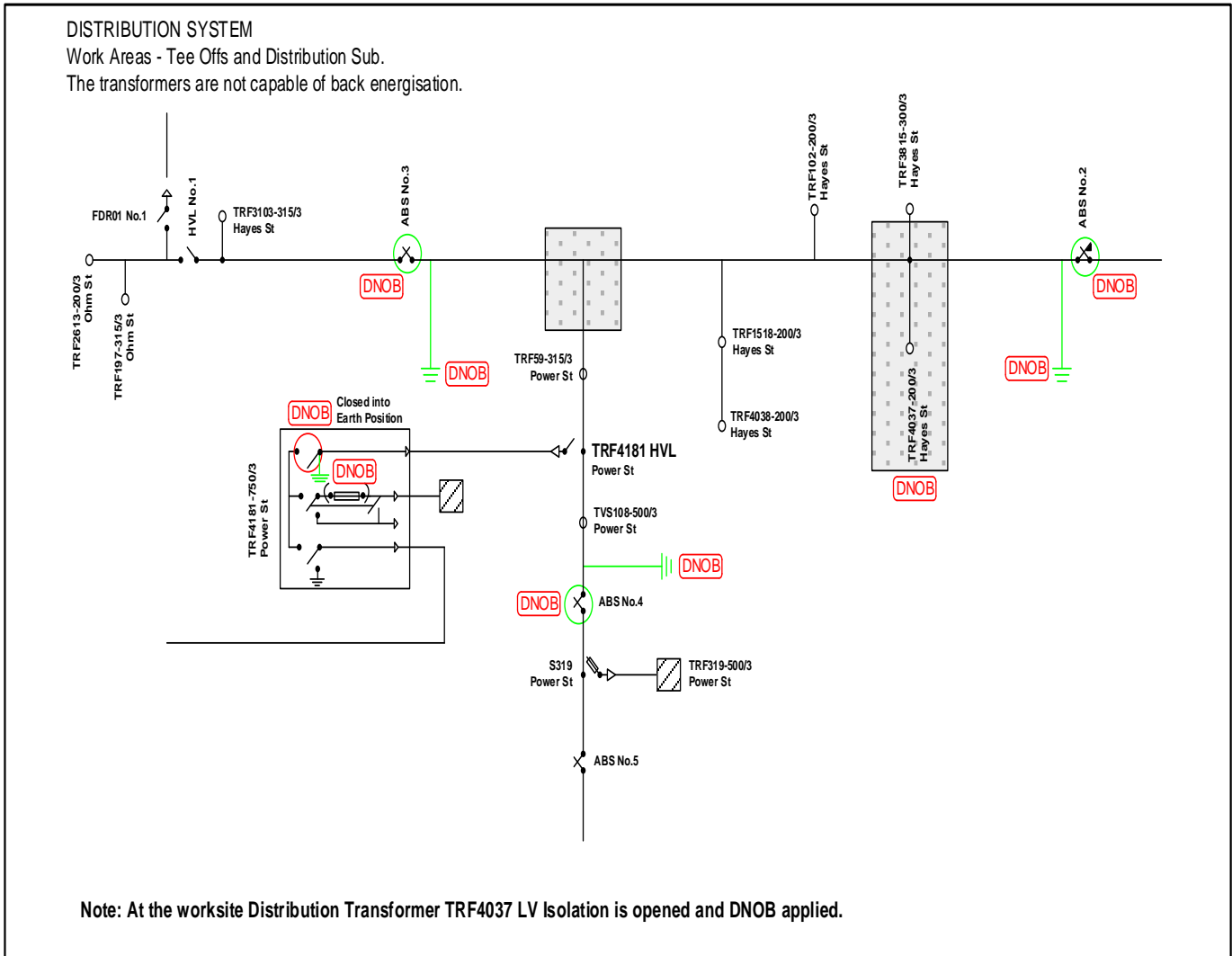

Earthing of High Voltage Electrical Apparatus for the Protection of Personnel

7.14. Overhead Distribution System Radial

Operator earths are placed so that earthed apparatus exists between each HV isolation point and the work area on the HV conductors prior to issue of an AP and to cause the work areas to be de-energised in the event of inadvertent re-energisation.

7.14.1. Example 1 – Radial Distribution System

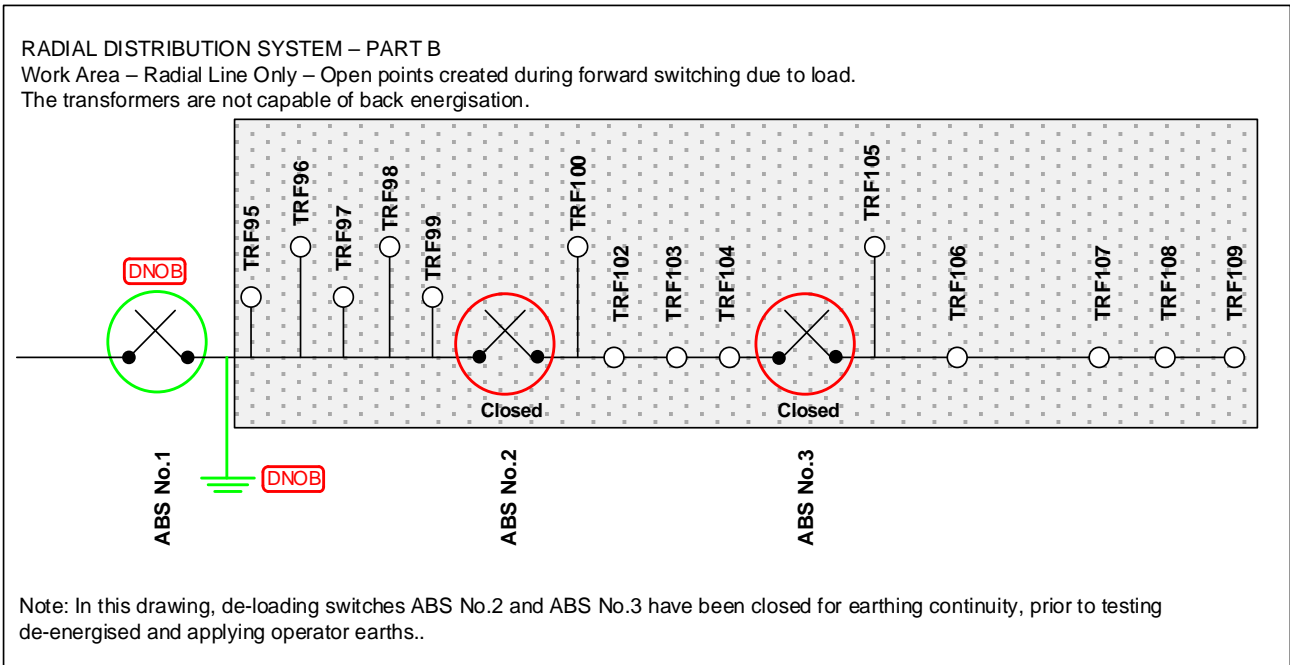
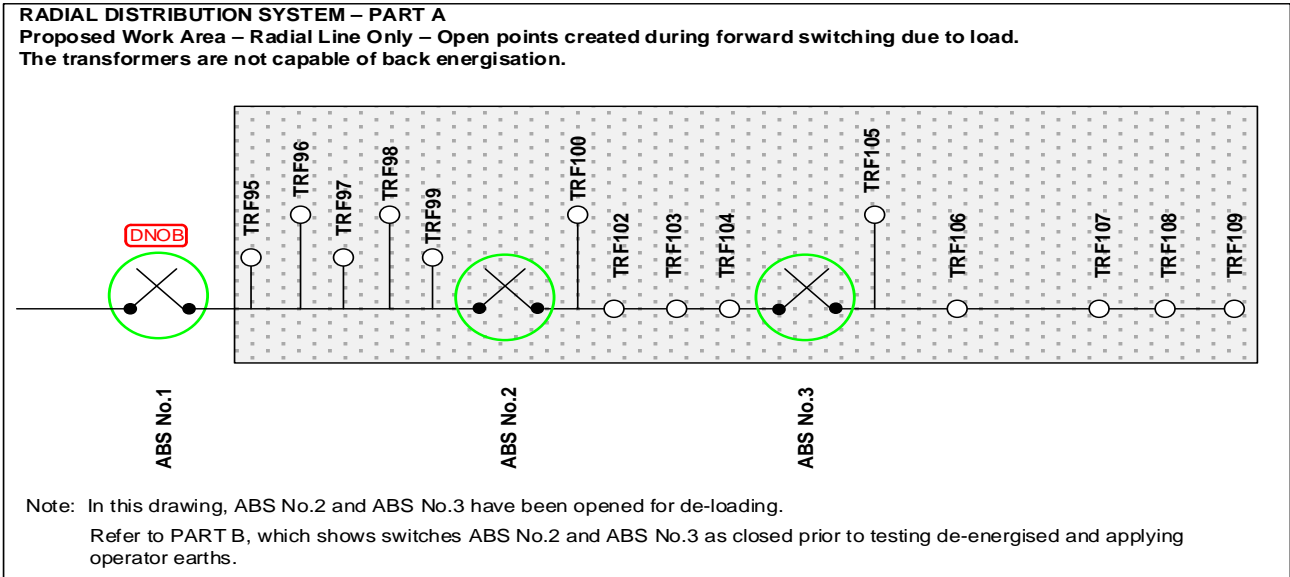

Earthing of High Voltage Electrical Apparatus for the Protection of Personnel

7.14.2. Example 2 – Radial Distribution System – Two Work Areas

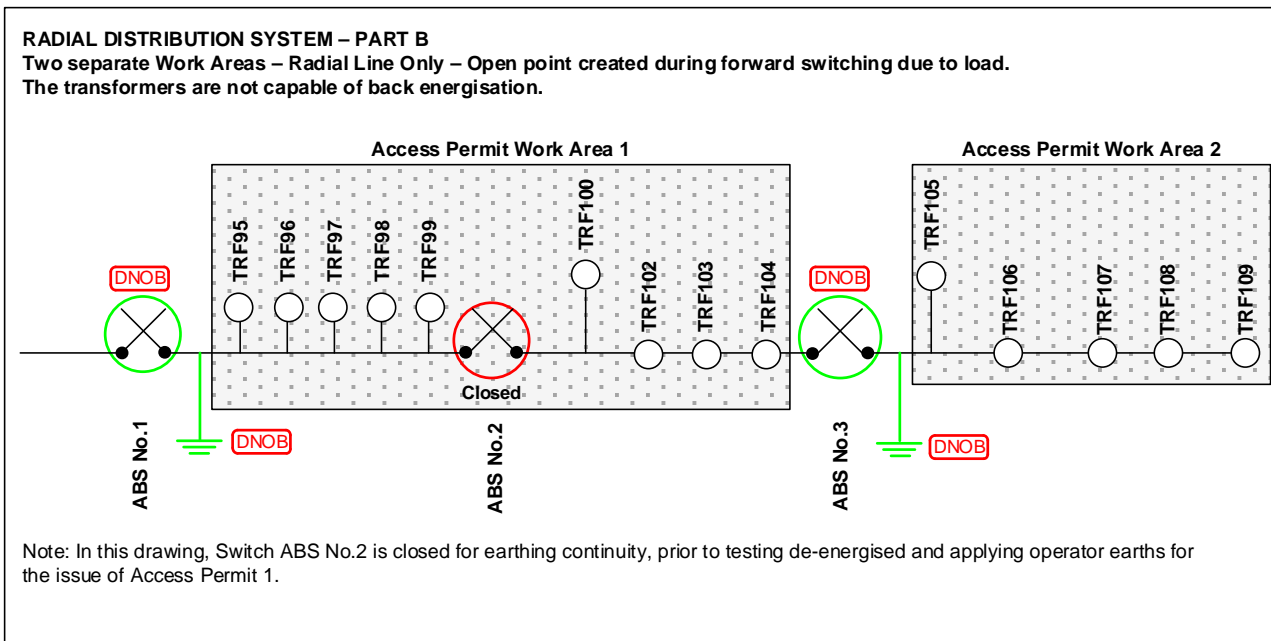
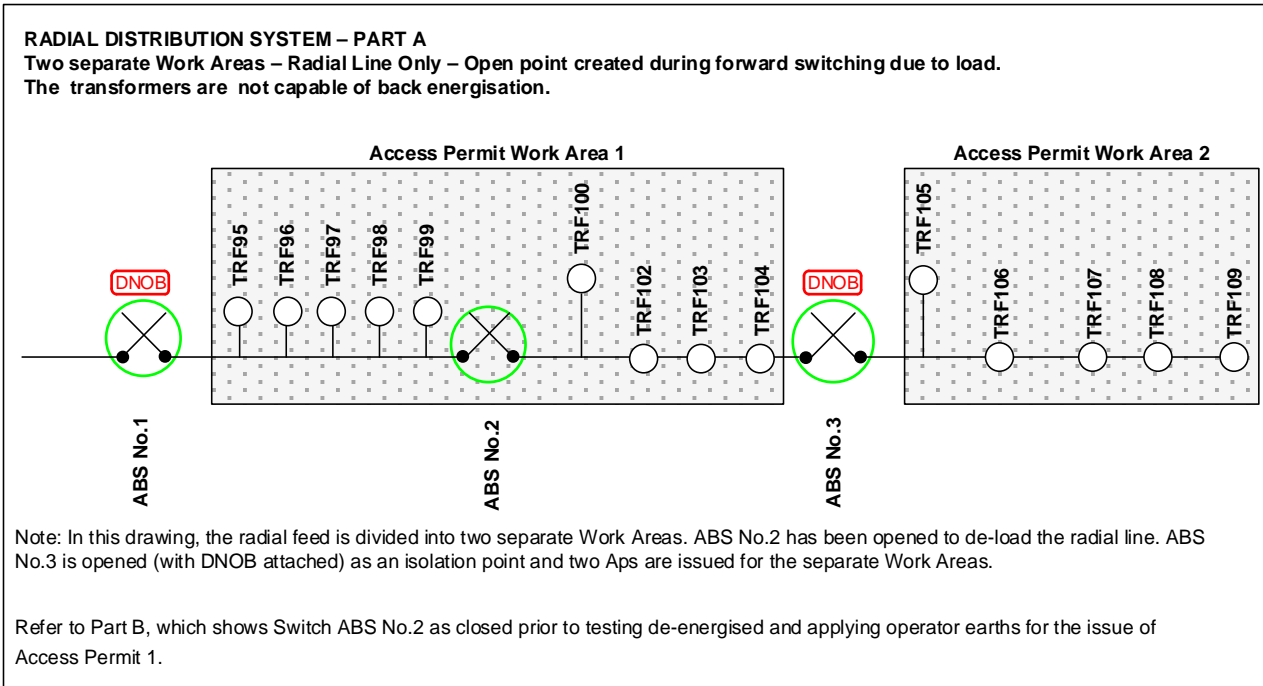

Earthing of High Voltage Electrical Apparatus for the Protection of Personnel

7.15. Single Wire Earth Return (SWER) Systems

Operator earths are placed so that a section of earthed conductor exists between each isolation point and the work site on the HV conductors prior to issue of AP and to cause the work areas to be de-energised in the event of inadvertent re-energisation.

Requirements for working earths are identified and placed as a Recipients' responsibility to cover the following:

- To safely discharge induced or residual voltage at the work area.
- To have an earth within sight of the work group.
- To reduce the rise in potential difference at the work area.

Operator earths shall be connected to a PEP where reasonable and practicable.

When working on a High Voltage Single Wire Earth Return (SWER) system, where reasonable and practicable, it is preferable that any earths applied to the SWER conductor to be worked on are connected to a PEP system which forms part of the HV SWER system (e.g. SWER distribution or isolating transformer).

Ergon Energy

Where an overhead SWER line that has been placed under access includes either reclosers, sectionalisers, line fuses or transformer EDO's that may open inadvertently, the Recipient shall maintain earthing downstream of these devices by applying Working Earths.

This is due to the large work area where the work crew may move along multiple sites and these sites may have significant distances between them. This removes the need for multiple Access Permits required to be issued and where there may be restricted communications.

Earthing of High Voltage Electrical Apparatus for the Protection of Personnel

7.15.1. SWER Isolation Transformer

A SWER isolation transformer shall be treated as an open point for the application of operator earths i.e. if the area to be accessed encompasses both sides of an isolating transformer then earthing shall be provided on both sides prior to the issue of any Permits.

7.15.2. Example 1 – Earthing of SWER Line – Known PEP at Isolation Point

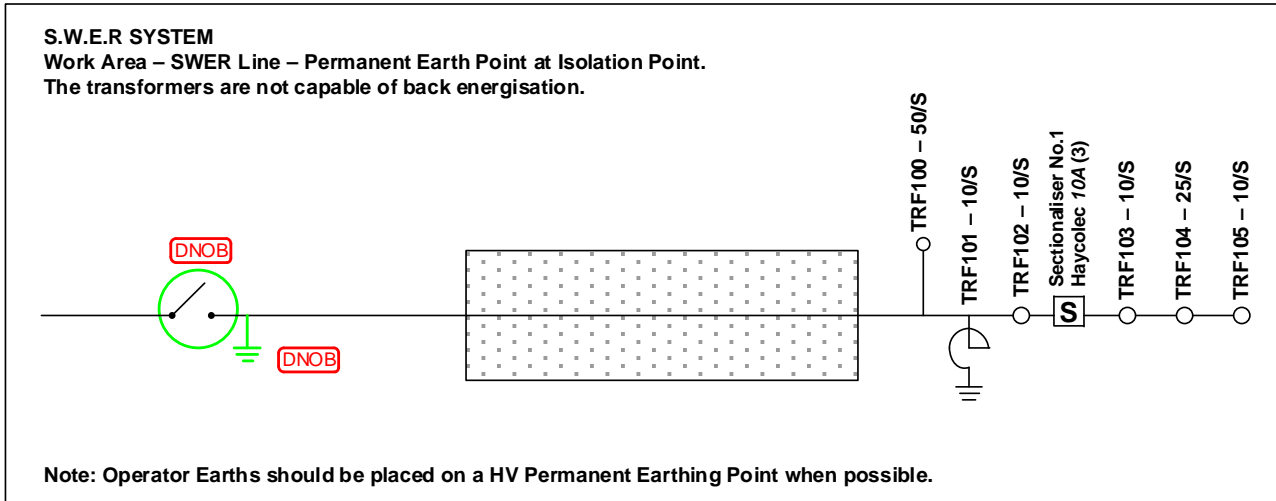

7.15.3. Example 2 – Earthing of SWER Line beyond an Automatic Circuit Recloser – Ergon Energy Only

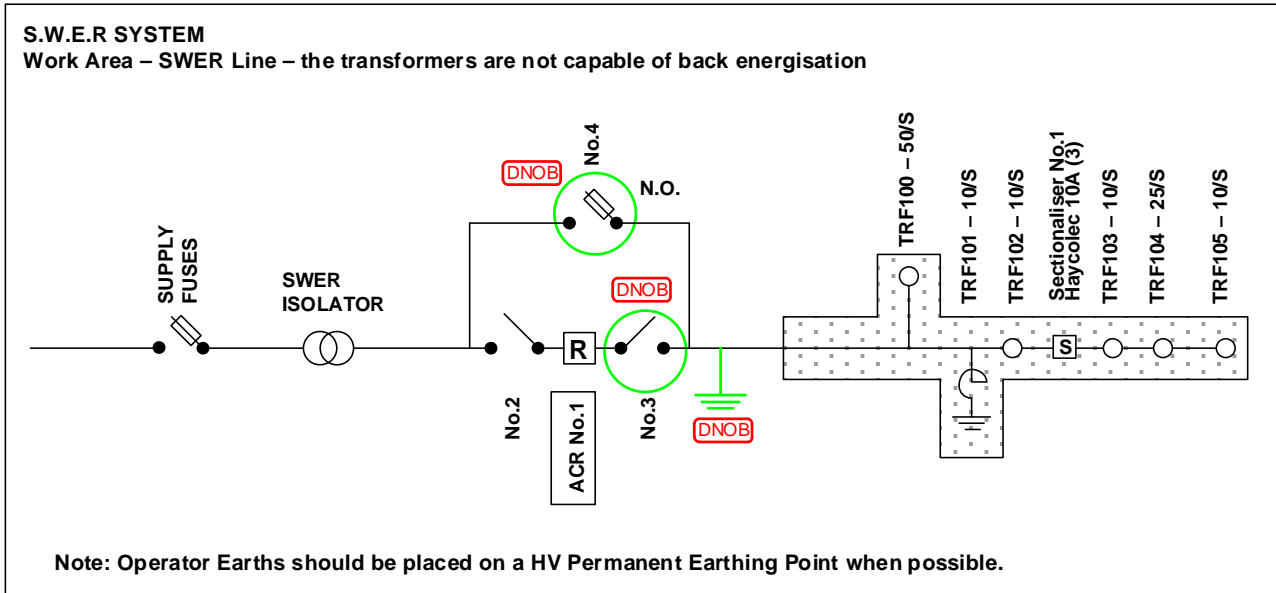

Earthing of High Voltage Electrical Apparatus for the Protection of Personnel

7.15.4. Example 3 – Earthing of SWER Isolator

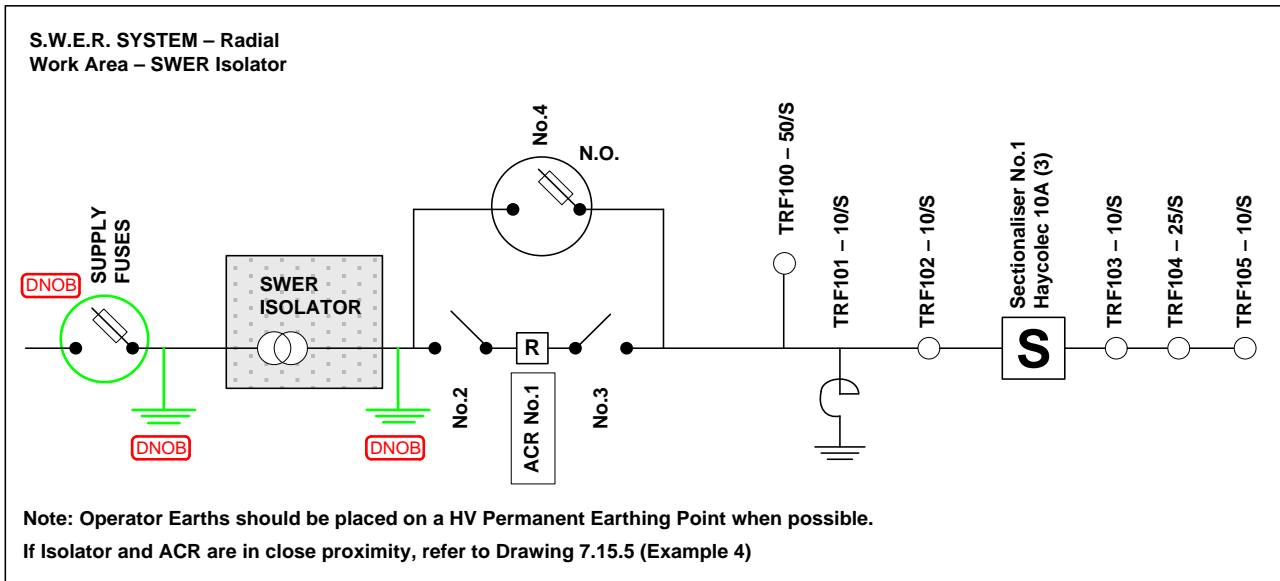

7.15.5. Example 4 – Earthing of SWER Isolator & SWER Line – One Work Area – Ergon Energy Only

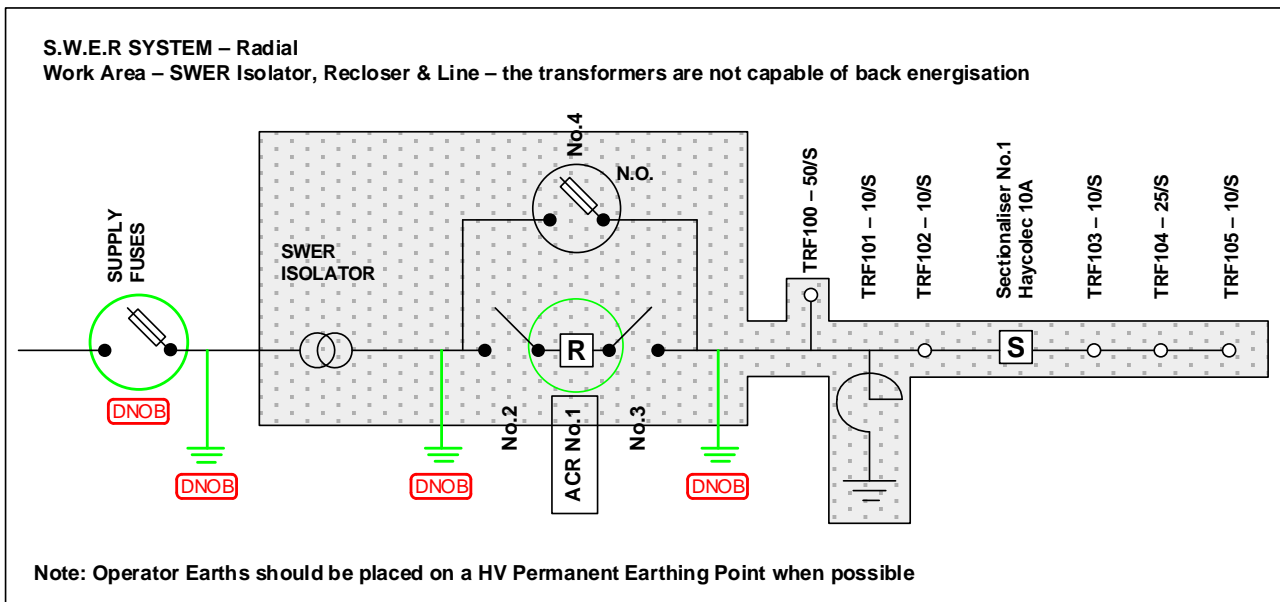

Earthing of High Voltage Electrical Apparatus for the Protection of Personnel

7.15.6. Example 6 – Access to Distribution Feeder Section & SWER Line – Ergon Energy Only

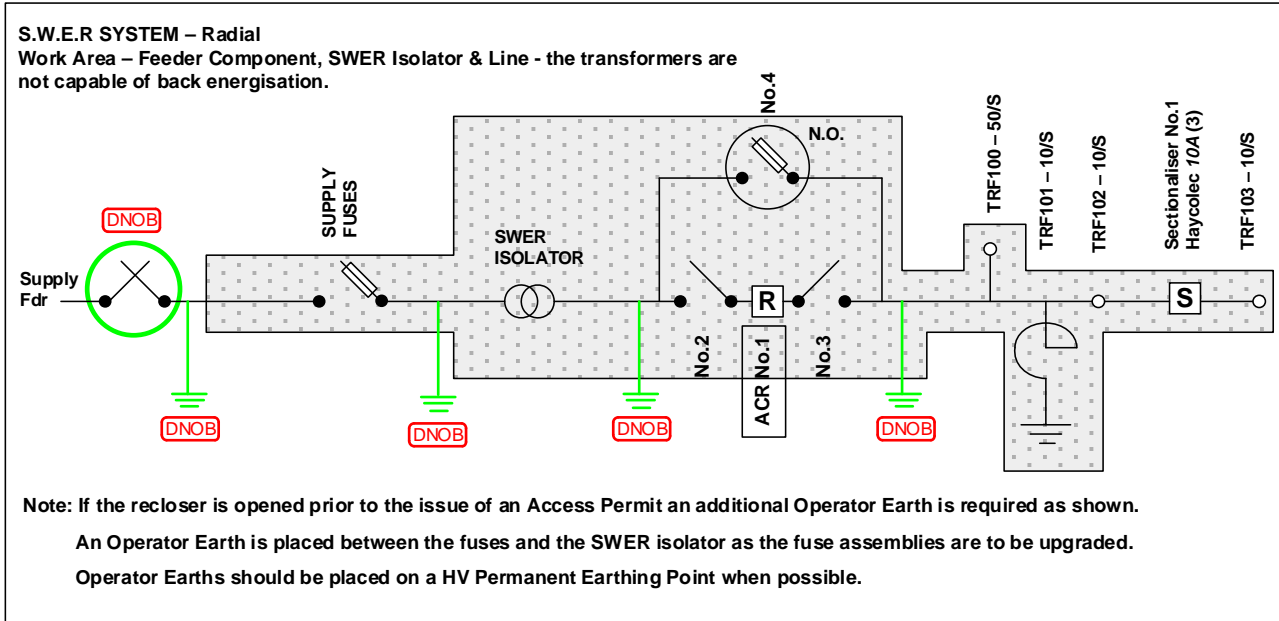

Earthing of High Voltage Electrical Apparatus for the Protection of Personnel



Part of the Energy Queensland Group

8. ASSESSING WORKING EARTH REQUIREMENTS

The following, is a guide provided to assist the Recipient and the Workgroup in assessing the risks and controls associated with the minimum Working Earth requirements. It is not exhaustive of all situations and after initial analysis and implementation of controls it may need to be revisited if conditions change at the Work Area.

The flowchart shall be read in conjunction with [Section 8.2 Instruction](#).

8.1. Flowchart

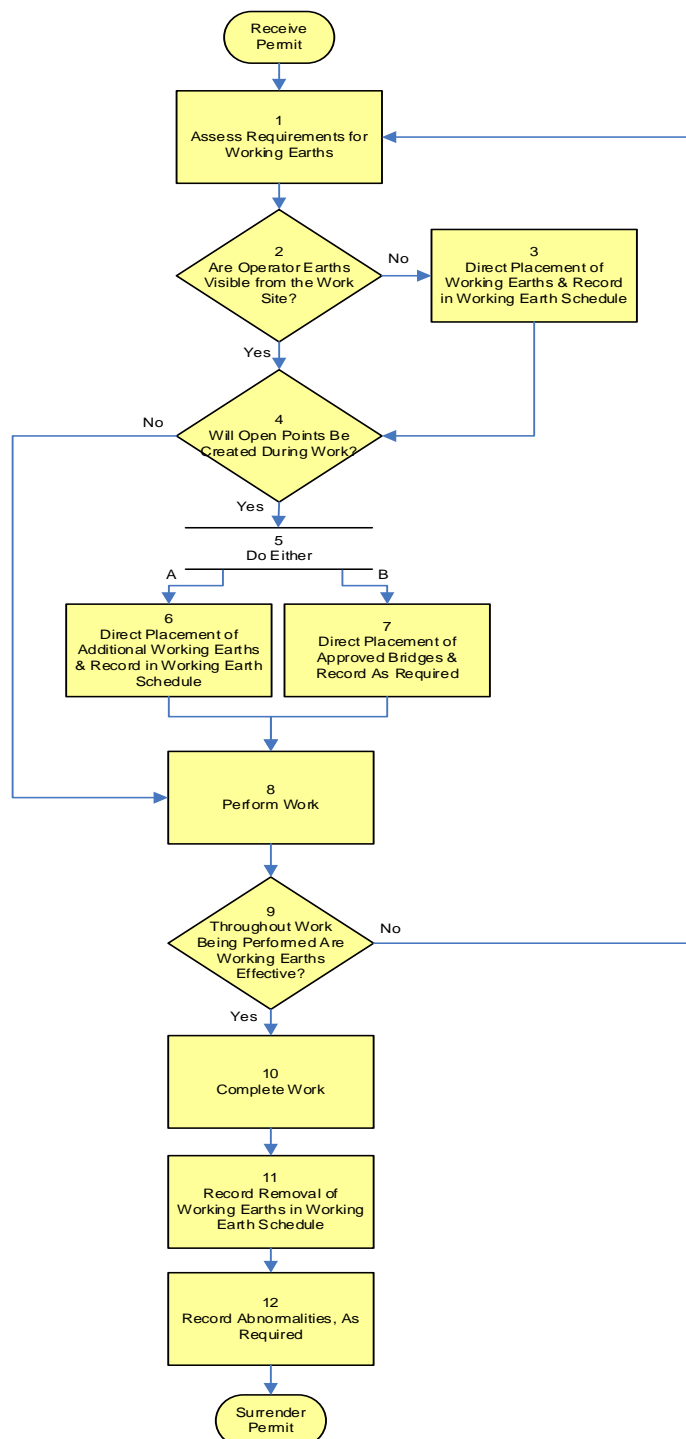

Earthing of High Voltage Electrical Apparatus for the Protection of Personnel

8.2. Instruction

1. Assess Requirements for Working Earths

On receipt of the Permit; the Recipient in consultation with the members of the workgroup shall perform a risk assessment to determine the Working Earth requirements for the work area.

Recipient shall ensure work is carried out between Earths, *where reasonable and practicable*. Recipient shall consider potential electrical hazards from:

- Electromagnetic and static induction;
- Overcrossings and undercrossing;
- Embedded generation;
- Back energisation from LV sources of supply;
- Discharge from stored electrical energy.

NOTE: Where there are multiple work areas under access, the Recipient shall contact other Recipient/s to coordinate earthing and earthing continuity to suit the progress of work. This will ensure the electrical safety of all workgroups in the work areas.

Performed By **Recipient**

2. Are Operator Earths Visible from the Work Site?

For access to overhead systems, if operator earths are visible from the work site and continuity can be confirmed and their integrity can be controlled and maintained, they may provide adequate protection for the work area in regards to safely discharging induced or residual voltages and limiting the rise in potential at the work area, further application of working earths may not be required.

NOTE: The Recipient shall ensure work is carried out between Earths, *where reasonable and practicable*.

Performed By **Recipient**

If NO go to 3 Direct Placement of Working Earths & Record in Working Earth Schedule
If YES go to 4 Will Open Points Be Created During Work?

3. Direct Placement of Working Earths & Record in Working Earth Schedule

The Recipient is to direct individuals of the work group to place Working Earths as required. Ensure the current-carrying capacity of a Working Earth is adequate to discharge stored or induced charge and to limit rise in potential difference at the work area.

Use Permanent Earthing Points (PEPs), *where reasonable and practicable*.

Record the location, time and date of Working Earths applied in the *Working Earth Schedule* of the relevant Permit.

Performed By **Recipient**

Earthing of High Voltage Electrical Apparatus for the Protection of Personnel



Part of the Energy Queensland Group

4. Will Open Points Be Created During Work?

The Recipient shall assess the work to be performed and identify any open points that will be created that affect the continuity of earthing, e.g. breaking bridges or cutting/spiking cables.

Performed By Recipient

If NO go to 8 Perform Work

If YES go to 5 Do Either

5. Do Either

Path A or B shall be followed to ensure continuity of earthing is maintained at the work area

Performed By Recipient

The next figure for "A" is 6 Direct Placement of Additional Working Earths & Record in Working Earth Schedule

The next figure for "B" is 7 Direct Placement of Approved Bridges & Record As Required

6. Direct Placement of Additional Working Earths & Record in Working Earth Schedule

Where open points are created that require equipotential bonding, the Recipient, shall direct the placement of adequate sets of Working Earths connected to a common Earthing point and record the location, time and date in the *Working Earth Schedule* of the relevant Permit. (**Note:** This may not be achievable for Underground cables). Where reasonable and practicable, workers should attempt to work in a zone of equipotential. Most importantly, no worker should contact two different potentials at the same time.

Performed By Recipient

7. Direct Placement of Approved Bridges & Record As Required

Where open points are created that require equipotential bonding, the Recipient, shall direct the placement of approved Bridges and record in accordance with approved procedures. (**Note:** This may not be achievable for underground cables). Where reasonable and practicable workers should attempt to work in a zone of equipotential. Most importantly, no worker should contact two different potentials at the same time.

Performed By Recipient

8. Perform Work

The Recipient / Workgroup shall perform the work as detailed on the relevant Permit.

Performed By Recipient / Workgroup

9. Throughout Work Being Performed, Are Working Earths Effective?

During each stage of the work being performed, the Recipient shall reassess the effectiveness of the Working Earths and if required, apply additional Working Earths to ensure that adequate earthing is maintained.

Earthing of High Voltage Electrical Apparatus for the Protection of Personnel

Performed By **Recipient**

If NO go to 1 Assess Requirements for Working Earths

If YES go to 10 Complete Work

10. Complete Work

The Recipient / Workgroup shall complete the work as detailed on the relevant Permit.

Performed By **Recipient / Workgroup**

11. Record Removal of Working Earths in Working Earth Schedule

On completion of the work, the Recipient shall inspect the work area to establish the status of the Working Earths and direct their removal, as required. The time and date Working Earths were removed shall be recorded in the *Working Earth Schedule* of the relevant Permit.

Performed By **Recipient**

12. Record Abnormalities, As Required

Where the removal of all Working Earths is not reasonable and practicable (for example, they are required for the subsequent issue of a new Permit), the Recipient shall obtain approval from the Switching Co-ordinator to leave the nominated Working Earths connected and record details of all Working Earths left in place in the *Abnormalities Section* of the relevant Permit, as required.

Performed By **Recipient**

Earthing of High Voltage Electrical Apparatus for the Protection of Personnel

9. NON-COMMISSIONED/DECOMMISSIONED ELECTRICAL APPARATUS

The dangers associated with working on non-commissioned or decommissioned electrical apparatus may be as great as those encountered on commissioned HV electrical apparatus. The placement of earths for the protection of personnel shall be assessed at all times. The following control measures shall be implemented prior to any work being undertaken on non-commissioned or decommissioned HV electrical apparatus. The requirements for earths shall be identified to all persons required to work on non-commissioned or decommissioned HV electrical apparatus and applied in accordance with [Section 10. Assessing Non-Commissioned & Decommissioned Earthing Requirements](#).

Where reasonable and practicable, earths shall be applied and all phases shall be short-circuited and earthed while work is in progress, taking into account the following:

- PEPs shall be used where reasonable and practicable.
- All earths applied and removed, including their location, shall be recorded on the relevant permit/authority/notices;
- Methods of disconnection from the commissioned network and or other non-commissioned apparatus;
- Nearby commissioned HV at the work site. Overcrossings and Undercrossings. Discharge from stored energy sources;
- Any required tests and the effect on other work crews and earthing;
- Where conductors or cables are to be broken, bridging removed or open points exist or are to be created, earthing continuity is to be maintained. This may be achieved through the use of earths applied on either side of the break bonded to a common earth or bridging leads. Where reasonable and practicable, workers should attempt to work in a zone of equipotential. Most importantly, no worker should contact two different potentials at the same time.
- Connectivity of conductors and works affecting continuity e.g. terminating new cables onto switchgear;
- Other precautions in place.

9.1. Management of Induction Hazards & Risks

For the management of induction risks and hazards on non-commissioned/decommissioned electrical apparatus see [Section 6.3 Management of Induction Hazards & Risks](#).

Earthing of High Voltage Electrical Apparatus for the Protection of Personnel

10. ASSESSING NON-COMMISSIONED & DECOMMISSIONED EARTHING REQUIREMENTS

The following, is a guide provided to assist the Commissioning Co-ordinator or On Site Supervisor and the Work Crew in assessing the risks and controls associated with the minimum earth requirements. It is not exhaustive of all situations and after initial analysis and implementation of controls it may need to be revisited if conditions change at the work site.

Earthing of High Voltage Electrical Apparatus for the Protection of Personnel

The flowchart shall be read in conjunction with [Section 10.2 Instruction](#).

10.1. Flowchart

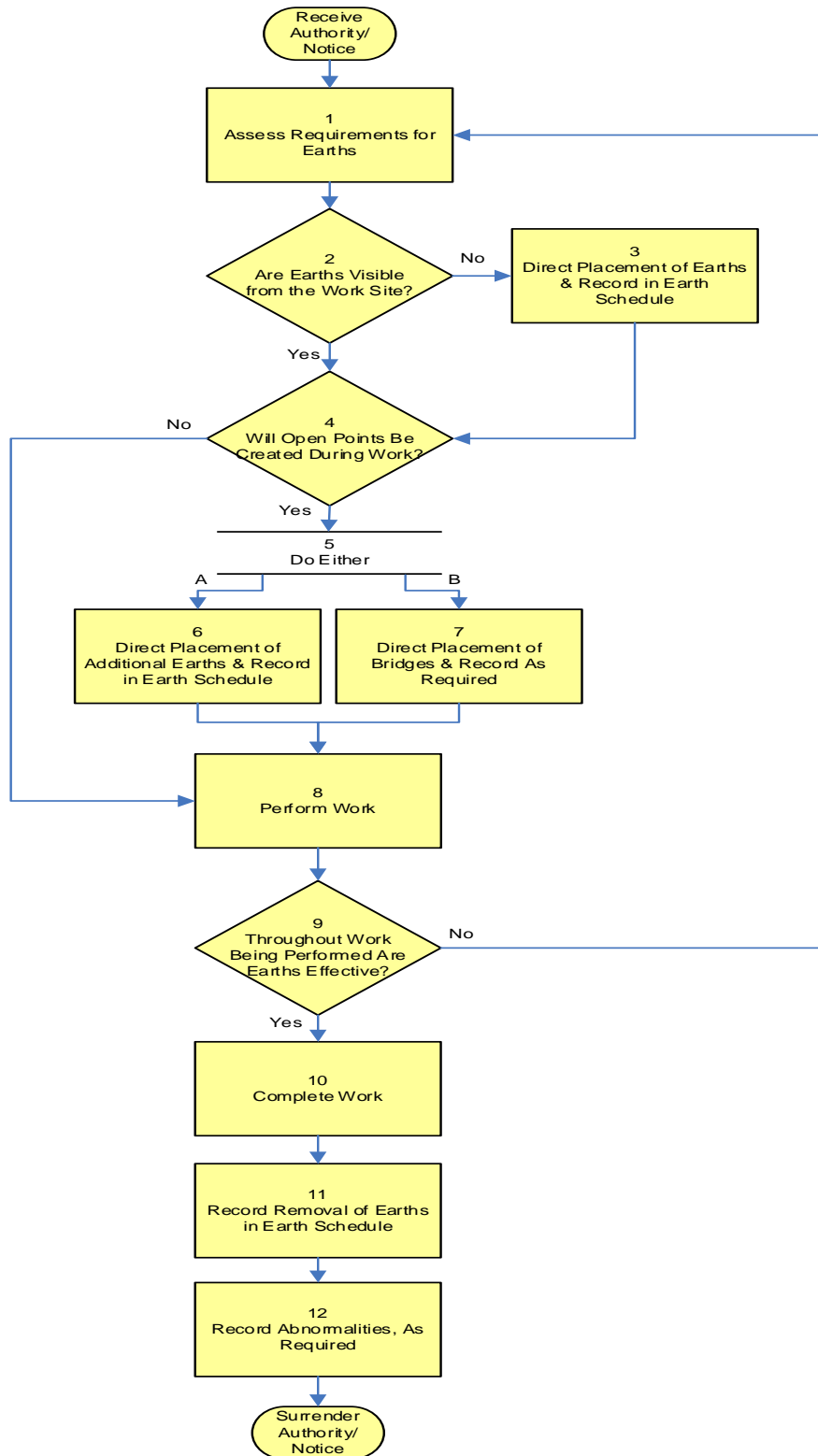

Earthing of High Voltage Electrical Apparatus for the Protection of Personnel

10.2. Instruction

1. Assess Requirements for Earthing Non-Commissioned or Decommissioned Apparatus

On receipt of the Authority / Notice; the Onsite Supervisor / Commissioning Co-ordinator in consultation with the members of the work crew shall perform a risk assessment to determine the Earthing requirements for the work site.

Onsite Supervisor / Commissioning Co-ordinator shall ensure work is carried out between Earths, *where reasonable and practicable*.

Onsite Supervisor / Commissioning Co-ordinator shall consider potential electrical hazards from:

- Electromagnetic and static induction and discharge from stored energy sources;
- Nearby commissioned HV at the work site or in proximity to the non-commissioned or decommissioned apparatus to be worked on;
- Any required pre-commissioning tests and the effect on other work crews and earthing;
- Connectivity of conductors and works affecting continuity e.g. terminating new cables onto switchgear, breaking bridges.
- Overcrossings and undercrossing;
- Back energisation from LV sources of supply.

Where multiple work sites are involved, the Onsite Supervisor / Commissioning Co-ordinator shall contact other Onsite Supervisor's / Commissioning Co-ordinator's to coordinate earthing; earthing continuity and connection of apparatus. This will ensure the electrical safety of all work crews at the work sites.

Performed By Onsite Supervisor / Commissioning Co-ordinator

2. Are Earths Visible from the Work Site?

Where one or more of the Earths are visible from the work site and continuity can be confirmed and their integrity can be controlled and maintained they may provide adequate protection for the work site, the Onsite Supervisor / Commissioning Co-ordinator shall determine whether further application of Earths is required at the work site.

NOTE: The Onsite Supervisor / Commissioning Co-ordinator shall ensure work is carried out between Earths, *where reasonable and practicable*.

Performed By Onsite Supervisor / Commissioning Co-ordinator

If NO go to 3 Direct Placement of Earths & Record in Earth Schedule

If YES go to 4 Will Open Points Be Created During Work?

Earthing of High Voltage Electrical Apparatus for the Protection of Personnel

3. Direct Placement of Earths & Record in Earth Schedule

The Onsite Supervisor / Commissioning Co-ordinator is to direct appropriately trained and qualified person to place Earths as required. Ensure the current-carrying capacity of an Earth is adequate to discharge stored or induced charge and to limit rise in potential difference at the work site.

Use Permanent Earthing Points (PEPs), where *reasonable and practicable*.

Record the location, time and date of Earths applied in the *Earth Schedule* of the relevant Authority / Notice, as required.

Performed By Onsite Supervisor / Commissioning Co-ordinator

4. Will Open Points Be Created During Work?

The Onsite Supervisor / Commissioning Co-ordinator shall assess the work to be performed and identify any open points that will be created that affect the continuity of earthing, e.g. breaking bridges or cutting / spiking cables.

Performed By Onsite Supervisor / Commissioning Co-ordinator

If NO go to 8 Perform Work

If YES go to 5 Do Either

5. Do Either

Path A or B shall be followed to ensure continuity of earthing is maintained at the work area where reasonable and practicable

Performed By Onsite Supervisor / Commissioning Co-ordinator

The next figure for "A" is 6 Direct Placement of Additional Earths & Record in Earth Schedule

The next figure for "B" is 7 Direct Placement of Bridges & Record As Required

6. Direct Placement of Additional Earths & Record in Earth Schedule

Where open points are created that require equipotential bonding, the On-site Supervisor / Commissioning Co-ordinator shall direct the placement of adequate sets of Earths connected to a common Earthing point and record the location, time and date in the *Earth Schedule* of the relevant Permit. Where reasonable and practicable, workers should attempt to work in a zone of equipotential. Most importantly, no worker should contact two different potentials at the same time.

Performed By Onsite Supervisor / Commissioning Co-ordinator

7. Direct Placement of Bridges & Record in Earth Schedule

Where open points are created that require equipotential bonding, the On-site Supervisor / Commissioning Co-ordinator shall direct the placement of Bridges and record in accordance with approved procedures. Where reasonable and practicable, workers should attempt to work in a zone of equipotential. Most importantly, no worker should contact two different potentials at the same time.

Performed By Onsite Supervisor / Commissioning Co-ordinator

Earthing of High Voltage Electrical Apparatus for the Protection of Personnel

8. Perform Work

The Onsite Supervisor / Commissioning Co-ordinator shall perform the work as detailed on the relevant Authority / Notice.

Performed By Onsite Supervisor / Commissioning Co-ordinator / Work Crew

9. Throughout Work Being Performed, Are Earths Effective?

Throughout each stage of the work being performed, the Onsite Supervisor / Commissioning Co-ordinator shall reassess the effectiveness of the Earths and if required, apply additional Earths to ensure that adequate earthing is maintained.

Performed By Onsite Supervisor / Commissioning Co-ordinator

If NO go to 1 Assess Requirements for Earths

If YES go to 10 Complete Work

10. Complete Work

The Onsite Supervisor / Commissioning Co-ordinator / Work Crew shall complete the work as detailed on the relevant Authority / Notice.

Performed By Onsite Supervisor / Commissioning Co-ordinator / Work Crew

11. Record Removal of Earths in Earth Schedule, As Required

On completion of the work, the Onsite Supervisor / Commissioning Co-ordinator shall inspect the work site to establish the status of the Earths and direct their removal, as required. The time and date Earths were removed shall be recorded in the *Earth Schedule* of the relevant Authority / Notice, as required.

Performed By Onsite Supervisor / Commissioning Co-ordinator

12. Record Abnormalities, As Required

If the earths that were placed prior to the issue of the Authority / Notice, or any additional earths placed during the course of the work are required for future work under a new Authority / Notice, the Onsite Supervisor / Commissioning Co-ordinator shall leave the nominated earths connected and record details in the *Abnormalities Section* of the relevant Authority / Notice and advise the Electricity Entity Representative.

Performed By Onsite Supervisor / Commissioning Co-ordinator